

# Model 707A Switching Matrix

Instruction Manual

Contains Operating and Servicing Information

**KEITHLEY**

# WARRANTY

Keithley Instruments, Inc. warrants this product to be free from defects in material and workmanship for a period of 1 year from date of shipment.

Keithley Instruments, Inc. warrants the following items for 90 days from the date of shipment: probes, cables, rechargeable batteries, diskettes, and documentation.

During the warranty period, we will, at our option, either repair or replace any product that proves to be defective.

To exercise this warranty, write or call your local Keithley representative, or contact Keithley headquarters in Cleveland, Ohio. You will be given prompt assistance and return instructions. Send the product, transportation prepaid, to the indicated service facility. Repairs will be made and the product returned, transportation prepaid. Repaired or replaced products are warranted for the balance of the original warranty period, or at least 90 days.

## LIMITATION OF WARRANTY

This warranty does not apply to defects resulting from product modification without Keithley's express written consent, or misuse of any product or part. This warranty also does not apply to fuses, software, non-rechargeable batteries, damage from battery leakage, or problems arising from normal wear or failure to follow instructions.

THIS WARRANTY IS IN LIEU OF ALL OTHER WARRANTIES, EXPRESSED OR IMPLIED, INCLUDING ANY IMPLIED WARRANTY OF MERCHANTABILITY OR FITNESS FOR A PARTICULAR USE. THE REMEDIES PROVIDED HEREIN ARE BUYER'S SOLE AND EXCLUSIVE REMEDIES.

NEITHER KEITHLEY INSTRUMENTS, INC. NOR ANY OF ITS EMPLOYEES SHALL BE LIABLE FOR ANY DIRECT, INDIRECT, SPECIAL, INCIDENTAL OR CONSEQUENTIAL DAMAGES ARISING OUT OF THE USE OF ITS INSTRUMENTS AND SOFTWARE EVEN IF KEITHLEY INSTRUMENTS, INC., HAS BEEN ADVISED IN ADVANCE OF THE POSSIBILITY OF SUCH DAMAGES. SUCH EXCLUDED DAMAGES SHALL INCLUDE, BUT ARE NOT LIMITED TO: COSTS OF REMOVAL AND INSTALLATION, LOSSES SUSTAINED AS THE RESULT OF INJURY TO ANY PERSON, OR DAMAGE TO PROPERTY.

# KEITHLEY

**Keithley Instruments, Inc.** • 28775 Aurora Road • Cleveland, OH 44139 • 440-248-0400 • Fax: 440-248-6168 • <http://www.keithley.com>

<b>CHINA:</b>	<b>Keithley Instruments China</b> • Yuan Chen Xin Building, Room 705 • 12 Yumin Road, Dewai, Madian • Beijing 100029 • 8610-62022886 • Fax: 8610-62022892
<b>FRANCE:</b>	<b>Keithley Instruments SARL</b> • BP 60 • 3 Allée des Garays • 91122 Palaiseau Cédex • 33-1-60-11-51-55 • Fax: 33-1-60-11-77-26
<b>GERMANY:</b>	<b>Keithley Instruments GmbH</b> • Landsberger Strasse 65 • D-82110 Germering, Munich • 49-89-8493070 • Fax: 49-89-84930759
<b>GREAT BRITAIN:</b>	<b>Keithley Instruments, Ltd.</b> • The Minster • 58 Portman Road • Reading, Berkshire RG30 1EA • 44-1189-596469 • Fax: 44-1189-575666
<b>ITALY:</b>	<b>Keithley Instruments SRL</b> • Viale S. Gimignano 38 • 20146 Milano • 39-2-48303008 • Fax: 39-2-48302274
<b>NETHERLANDS:</b>	<b>Keithley Instruments BV</b> • Avelingen West 49 • 4202 MS Gorinchem • 31-(0)183-635333 • Fax: 31-(0)183-630821
<b>SWITZERLAND:</b>	<b>Keithley Instruments SA</b> • Kriesbachstrasse 4 • 8600 Dübendorf • 41-1-8219444 • Fax: 41-1-8203081
<b>TAIWAN:</b>	<b>Keithley Instruments Taiwan</b> • 1FL., 85 Po Ai Street • Hsinchu, Taiwan • 886-35-778462 • Fax: 886-35-778455

# Model 707A Switching Matrix Instruction Manual

©1998, Keithley Instruments, Inc.  
All rights reserved.  
Cleveland, Ohio, U.S.A.  
First Printing, September 1998  
Document Number: 707A-901-01 Rev. A

# Manual Print History

The print history shown below lists the printing dates of all Revisions and Addenda created for this manual. The Revision Level letter increases alphabetically as the manual undergoes subsequent updates. Addenda, which are released between Revisions, contain important change information that the user should incorporate immediately into the manual. Addenda are numbered sequentially. When a new Revision is created, all Addenda associated with the previous Revision of the manual are incorporated into the new Revision of the manual. Each new Revision includes a revised copy of this print history page.

Revision A (Document Number 707A-901-01) ..... September 1998

# Safety Precautions

---

The following safety precautions should be observed before using this product and any associated instrumentation. Although some instruments and accessories would normally be used with non-hazardous voltages, there are situations where hazardous conditions may be present.

This product is intended for use by qualified personnel who recognize shock hazards and are familiar with the safety precautions required to avoid possible injury. Read the operating information carefully before using the product.

The types of product users are:

**Responsible body** is the individual or group responsible for the use and maintenance of equipment, and for ensuring that operators are adequately trained.

**Operators** use the product for its intended function. They must be trained in electrical safety procedures and proper use of the instrument. They must be protected from electric shock and contact with hazardous live circuits.

**Maintenance personnel** perform routine procedures on the product to keep it operating, for example, setting the line voltage or replacing consumable materials. Maintenance procedures are described in the manual. The procedures explicitly state if the operator may perform them. Otherwise, they should be performed only by service personnel.

**Service personnel** are trained to work on live circuits, and perform safe installations and repairs of products. Only properly trained service personnel may perform installation and service procedures.

Exercise extreme caution when a shock hazard is present. Lethal voltage may be present on cable connector jacks or test fixtures. The American National Standards Institute (ANSI) states that a shock hazard exists when voltage levels greater than 30V RMS, 42.4V peak, or 60VDC are present. **A good safety practice is to expect that hazardous voltage is present in any unknown circuit before measuring.**

Users of this product must be protected from electric shock at all times. The responsible body must ensure that users are prevented access and/or insulated from every connection point. In some cases, connections must be exposed to potential human contact. Product users in these circumstances must be trained to protect themselves from the risk of electric shock. If the circuit is capable of operating at or above 1000 volts, **no conductive part of the circuit may be exposed.**

As described in the International Electrotechnical Commission (IEC) Standard IEC 664, digital multimeter measuring circuits (e.g., Keithley Models 175A, 199, 2000, 2001, 2002, and 2010) measuring circuits are Installation Category II. All other instruments' signal terminals are Installation Category I and must not be connected to mains.

Do not connect switching cards directly to unlimited power circuits. They are intended to be used with impedance limited sources. NEVER connect switching cards directly to AC mains. When connecting sources to switching cards, install protective devices to limit fault current and voltage to the card.

Before operating an instrument, make sure the line cord is connected to a properly grounded power receptacle. Inspect the connecting cables, test leads, and jumpers for possible wear, cracks, or breaks before each use.

For maximum safety, do not touch the product, test cables, or any other instruments while power is applied to the circuit under test. ALWAYS remove power from the entire test system and discharge any capacitors before: connecting or disconnecting cables or jumpers, installing or removing switching cards, or making internal changes, such as installing or removing jumpers.


Do not touch any object that could provide a current path to the common side of the circuit under test or power line (earth) ground. Always make measurements with dry hands while standing on a dry, insulated surface capable of withstanding the voltage being measured.


Do not exceed the maximum signal levels of the instruments and accessories, as defined in the specifications and operating information, and as shown on the instrument or test fixture panels, or switching card.


When fuses are used in a product, replace with same type and rating for continued protection against fire hazard.

Chassis connections must only be used as shield connections for measuring circuits, NOT as safety earth ground connections.

If you are using a test fixture, keep the lid closed while power is applied to the device under test. Safe operation requires the use of a lid interlock.

If a  screw is present, connect it to safety earth ground using the wire recommended in the user documentation.

The  symbol on an instrument indicates that the user should refer to the operating instructions located in the manual.

The  symbol on an instrument shows that it can source or measure 1000 volts or more, including the combined effect of normal and common mode voltages. Use standard safety precautions to avoid personal contact with these voltages.

The **WARNING** heading in a manual explains dangers that might result in personal injury or death. Always read the associated information very carefully before performing the indicated procedure.

The **CAUTION** heading in a manual explains hazards that could damage the instrument. Such damage may invalidate the warranty.

Instrumentation and accessories shall not be connected to humans.

Before performing any maintenance, disconnect the line cord and all test cables.

To maintain protection from electric shock and fire, replacement components in mains circuits, including the power transformer, test leads, and input jacks, must be purchased from Keithley Instruments. Standard fuses, with applicable national safety approvals, may be used if the rating and type are the same. Other components that are not safety related may be purchased from other suppliers as long as they are equivalent to the original component. (Note that selected parts should be purchased only through Keithley Instruments to maintain accuracy and functionality of the product.) If you are unsure about the applicability of a replacement component, call a Keithley Instruments office for information.

To clean the instrument, use a damp cloth or mild, water based cleaner. Clean the exterior of the instrument only. Do not apply cleaner directly to the instrument or allow liquids to enter or spill on the instrument.

# 707A Switching Matrix Specifications

## Overview

**CAPACITY:** Six plug-in cards per mainframe.

**EXPANSION CAPACITY:** Daisy-chain expansion of up to four Slave units with one Master unit.

**ANALOG BACKPLANES:** Backplanes provide automatic row expansion between similar cards within one mainframe.

**DISPLAY:** 14-segment alphanumeric LED display, plus individual status LEDs.

**MEMORY:** Storage for 100 matrix setups, lithium battery backup.

**PROGRAMMED SETTING TIME:** 0 to 65 seconds in 1ms increments.

**FRONT PANEL MENU:** Digital I/O; External Trigger edge; Matrix Ready level; Master/Slave operation; IEEE-488 address; Relay Settling Time; Self Test; Card Identify; factory defaults.

**TRIGGER SOURCES:** External Trigger (TTL compatible, programmable edge, 600ns minimum pulse width); IEEE-488 bus (TALK, GET, "X"); manual.

**STATUS OUTPUT:** Matrix Ready (TTL compatible, programmable high or low true); goes false when relays are switched, true at end of Programmed Settling Time.

**MAKE BEFORE BREAK, BREAK BEFORE MAKE:** Programmable by row.

**LIGHT PEN OPTION:** Controls crosspoints, memories, make before break and break before make. One light pen controls Master and all Slaves.

## Execution Speed

**MAXIMUM TRIGGER RATE:** 200 setups per second (stepping through previously stored setups with make-before-break and break-before-make disabled).

**TRIGGER RESPONSE TIME:**

External Trigger: <1ms.

IEEE-488 GET: <1ms.

**RESPONSE TO IEEE-488 COMMAND (to close a single relay, excluding relay settling time):**

Stand Alone: <15ms.

Master and Four Slaves: <55ms.

**DOWNLOAD TIME (one setup to 707A):**

Stand Alone: 60ms typical.

## IEEE-488 BUS IMPLEMENTATION

**MULTILINE COMMANDS:** DCL, LLO, SDC, GET, GTL, UNT, UNL, SPE, SPD

**UNILINE COMMANDS:** IFC, REN, EOI, SRQ, ATN.

**INTERFACE FUNCTIONS:** SH1, AH1, T6, TE0, L4, LE0, SR1, RL1, PP0, DC1, DT1, C0, E1.

**PROGRAMMABLE PARAMETERS:** All parameters programmable except for IEEE-488 bus address and Master/Slave operating mode.

## GENERAL

**DIGITAL I/O (TTL compatible):**

Data: 8 inputs, 8 outputs.

Control: Input Latch, Output Strobe.

**REAR PANEL CONNECTORS:**

Two BNC: External Trigger, Matrix Ready.

One DB-25: Digital I/O.

Two 8-pin DIN: Mater/Slave In, Mater/Slave Out.

One 6-pin Screw Terminal Plug: Relay Test.

**ENVIRONMENTAL:**

Operating: 0 to 50 C.

Storage: -25 to 65 C.

**POWER:** 100 to 240 VAC, 50-60Hz, 250VA maximum.

**RELAY DRIVE:** 5A minimum per card (slot).

**EMC:** Conforms with European Union Directive 89/336/EEC EN 55011, EN 50082-1, EN 61000-3-3, FCC part 15 class B.

**SAFETY:** Conforms with European Union Directive 73/23/EEC EN 61010-1.

**PHYSICAL:** 356mm high x 432mm wide x 574mm deep (14 in x 17 in x 22.6 in). Net weight without cards 16.5kg (36 lbs).

**ACCESSORIES SUPPLIED:** Instruction manual, power line cord, relay test connector, fixed rack mounting hardware.

**ACCESSORIES AVAILABLE:**

Model 7078-PEN: Programming Light Pen (includes holder)

Model 7079: Slide Rack Mounting Kit

Model 7078-DIN: 8-pin DIN cable (Master/Slave), 1.8m (6ft.)

Specifications are subject to change without notice.

# Table of Contents

---

<b>1</b>	<b>General Information</b>	
1.1	Introduction .....	1-1
1.2	Features .....	1-1
1.3	Warranty information .....	1-1
1.4	Manual addenda .....	1-1
1.5	Safety symbols and terms .....	1-2
1.6	Specifications .....	1-2
1.7	Unpacking and inspection .....	1-2
1.7.1	Inspection for damage .....	1-2
1.7.2	Shipment contents .....	1-2
1.8	Repacking for shipment .....	1-2
1.9	Optional accessories .....	1-2
<b>2</b>	<b>Card Installation</b>	
2.1	Installing and removing cards .....	2-1
<b>3</b>	<b>Getting Started</b>	
3.1	Introduction .....	3-1
3.2	Front panel familiarization .....	3-1
3.3	Rear panel familiarization .....	3-6
3.4	Card connections .....	3-8
3.5	Expanding matrix size .....	3-10
3.5.1	Single unit expansion .....	3-10
3.5.2	Multiple unit expansion .....	3-16
3.5.3	System expansion issues .....	3-20
3.5.4	Documenting system configuration .....	3-20
3.6	Basic switching operation .....	3-22
3.6.1	Power-up .....	3-22
3.6.2	Selecting make/break and break/make rows .....	3-22
3.6.3	Modifying a relay setup .....	3-22
3.6.4	Storing setup and sending to relays .....	3-23



## 4 Operation

4.1	Introduction .....	4-1
4.2	Setup data paths .....	4-1
4.3	Power-up procedure .....	4-2
4.3.1	Line voltage selection .....	4-2
4.3.2	Line power connections .....	4-2
4.3.3	Power switch .....	4-2
4.3.4	Power-up self-test and messages .....	4-2
4.3.5	Power-up configuration .....	4-3
4.3.6	Master/slave power-up .....	4-4
4.4	Displays and messages .....	4-4
4.4.1	Alphanumeric display .....	4-4
4.4.2	Display messages .....	4-5
4.4.3	IEEE-488 status indicators .....	4-6
4.4.4	Crosspoint display LEDs .....	4-6
4.4.5	Make/break and break/make LEDs .....	4-8
4.4.6	Light pen .....	4-8
4.5	Selecting crosspoint display .....	4-10
4.6	Modifying crosspoint display .....	4-10
4.7	Copying crosspoint display .....	4-11
4.8	Inserting and deleting stored setups .....	4-12
4.9	Menu operations .....	4-12
4.9.1	Digital I/O .....	4-14
4.9.2	External trigger .....	4-14
4.9.3	Matrix ready .....	4-15
4.9.4	Stand-alone and master/slave .....	4-16
4.9.5	IEEE-488 bus address .....	4-17
4.9.6	Relay (hardware) settling times .....	4-18
4.9.7	Card labels .....	4-18
4.9.8	Self-test .....	4-18
4.9.9	Factory defaults .....	4-18
4.10	Selecting switching parameters .....	4-19
4.10.1	Programmed settling time .....	4-19
4.10.2	Make/break and break/make rows .....	4-19
4.11	Triggering .....	4-20
4.11.1	Trigger sources .....	4-20
4.11.2	Front panel triggering .....	4-21
4.11.3	Trigger overrun conditions .....	4-21
4.11.4	External trigger input .....	4-25
4.11.5	Matrix ready output .....	4-25
4.11.6	IEEE-488 bus triggering .....	4-25
4.12	Resetting .....	4-25

## 5 IEEE-488 Programming

5.1	Introduction .....	5-1
5.2	IEEE-488 quick start .....	5-1
5.3	Bus cable connections .....	5-3
5.4	Interface function codes .....	5-5
5.5	Primary address programming .....	5-6
5.6	QuickBASIC programming .....	5-7
5.7	Front panel aspects of IEEE-488 operation .....	5-8
5.7.1	Front panel error messages .....	5-8
5.7.2	Status indicators .....	5-9
5.7.3	Local key .....	5-10
5.7.4	Concurrent front panel and bus operation .....	5-10
5.8	General bus command programming .....	5-10
5.8.1	Overview .....	5-10
5.8.2	REN (remote enable) .....	5-10
5.8.3	IFC (interface clear) .....	5-11
5.8.4	LLO (local lockout) .....	5-11
5.8.5	GTL (go to local) .....	5-11
5.8.6	DCL (device clear) .....	5-11
5.8.7	SDC (selective device clear) .....	5-11
5.8.8	GET (group executive trigger) .....	5-11
5.8.9	SPE, SPD ( serial polling) .....	5-11
5.9	Device-dependent command (DDC) programming .....	5-12
5.9.1	Overview .....	5-12
5.9.2	A — External trigger .....	5-16
5.9.3	B — Matrix ready .....	5-17
5.9.4	C — Close crosspoint .....	5-18
5.9.5	D — Display .....	5-18
5.9.6	E — Edit pointer .....	5-19
5.9.7	F — Enable/disable triggers .....	5-19
5.9.8	G — Data format .....	5-20
5.9.9	H — Hit key .....	5-25
5.9.10	I — Insert blank setup .....	5-26
5.9.11	J — Self-test .....	5-26
5.9.12	K — EOI and hold-off .....	5-26
5.9.13	L — Download setups .....	5-27
5.9.14	M — SRQ and serial poll byte .....	5-28
5.9.15	N — Open crosspoint .....	5-30
5.9.16	O — Digital output .....	5-30
5.9.17	P — Clear crosspoints .....	5-31
5.9.18	Q — Delete setup .....	5-31
5.9.19	R — Restore defaults .....	5-32
5.9.20	S — Programmed settling time .....	5-32
5.9.21	T — Trigger .....	5-33
5.9.22	U — Status .....	5-34
5.9.23	V — Make/break .....	5-39
5.9.24	W — Break/make .....	5-39
5.9.25	X — Execute .....	5-40
5.9.26	Y — Terminator .....	5-41
5.9.27	Z — Copy setup .....	5-41
5.10	Relay command combinations .....	5-42
5.11	Timing considerations .....	5-43

## 6 Principles of Operation

6.1	Introduction .....	6-1
6.2	Overall function description .....	6-1
6.3	Microcomputer .....	6-1
6.3.1	Reset circuit .....	6-1
6.3.2	Address decoding .....	6-2
6.3.3	Memory .....	6-4
6.4	Relay control circuitry .....	6-4
6.4.1	Switching card interface .....	6-6
6.4.2	Switching card logic .....	6-6
6.5	Display circuitry .....	6-10
6.5.1	Display data .....	6-13
6.5.2	Front panel keys .....	6-13
6.5.3	Display interface .....	6-13
6.5.4	Refresh display/read keyboard .....	6-14
6.6	Light pen interface .....	6-14
6.7	Master/slave circuitry .....	6-15
6.7.1	Serial communication .....	6-15
6.7.2	Control signals .....	6-17
6.8	Digital I/O .....	6-17
6.9	IEEE-488 bus interface .....	6-17
6.10	Power supply .....	6-19

## 7 Maintenance

7.1	Introduction .....	7-1
7.2	Line voltage sensing .....	7-1
7.3	Fuse replacement .....	7-2
7.4	Fixed rack installation .....	7-2
7.5	Disassembly .....	7-5
7.6	Backplane jumpers .....	7-7
7.7	Battery replacement .....	7-9
7.8	Static-sensitive devices .....	7-9
7.9	Mainframe troubleshooting .....	7-9
7.9.1	Recommended test equipment .....	7-10
7.9.2	Power-up self-test .....	7-10
7.9.3	Power supply checks .....	7-10
7.9.4	Digital board checks .....	7-10
7.9.5	Display board checks .....	7-14
7.10	Using an extender card .....	7-16
7.11	Cleaning .....	7-16
7.11.1	Backplane .....	7-16
7.11.2	Fan filter .....	7-16

## 8 Replaceable Parts

8.1	Introduction .....	8-1
8.2	Parts lists .....	8-1
8.3	Ordering information .....	8-1
8.4	Factory service .....	8-1
8.5	Component layouts and schematics .....	8-1

## A Card Configuration Worksheet

### B IEEE-488 Bus Overview

B.1	Introduction .....	B-1
B.2	Bus description .....	B-1
B.3	Bus lines .....	B-3
B.3.1	Data lines .....	B-3
B.3.2	Bus management lines .....	B-3
B.3.3	Handshake lines .....	B-3
B.4	Bus commands .....	B-4
B.4.1	Uniline commands .....	B-4
B.4.2	Universal multiline commands .....	B-5
B.4.3	Addressed multiline commands .....	B-5
B.4.4	Address commands .....	B-5
B.4.5	Unaddress commands .....	B-5
B.4.6	Command codes .....	B-5
B.4.7	Typical command sequences .....	B-7
B.4.8	IEEE command groups .....	B-7
B.5	Interface function codes .....	B-8

# List of Illustrations

---

## 2 Card Installation

Figure 2-1	Installing a matrix card .....	2-2
------------	--------------------------------	-----

## 3 Getting Started

Figure 3-1	Model 707A front panel .....	3-2
Figure 3-2	Setup data transfers .....	3-3
Figure 3-3	Model 707A rear panel .....	3-7
Figure 3-4	Connecting instruments to rows .....	3-8
Figure 3-5	Connecting instruments to columns .....	3-9
Figure 3-6	Backplane buses .....	3-10
Figure 3-7	Backplane expansion of analog bus #1 .....	3-11
Figure 3-8	Backplane expansion of analog bus #2 .....	3-12
Figure 3-9	Backplane expansion of analog bus #3 .....	3-13
Figure 3-10	Row connection examples .....	3-14
Figure 3-11	Example of partial matrix expansion .....	3-15
Figure 3-12	Model 7071 row connections of stand-alone units .....	3-16
Figure 3-13	Example of master/slave interconnect cables .....	3-17
Figure 3-14	Master/slave column locations .....	3-18
Figure 3-15	Example of master/slave row expansion .....	3-19

## 4 Operation

Figure 4-1	Paths for relay setup data .....	4-1
Figure 4-2	Alphanumeric display .....	4-4
Figure 4-3	Crosspoint display .....	4-7
Figure 4-4	Light pen .....	4-9
Figure 4-5	Crosspoint display keys .....	4-10
Figure 4-6	Data entry keys .....	4-11
Figure 4-7	Memory keys .....	4-12
Figure 4-8	Digital I/O port .....	4-14
Figure 4-9	Rear panel BNC jacks .....	4-14
Figure 4-10	Sample external trigger pulses .....	4-15
Figure 4-11	Sample matrix ready pulses .....	4-15
Figure 4-12	Master/slave connectors .....	4-16
Figure 4-13	IEEE-488 bus connector .....	4-17
Figure 4-14	Switching keys .....	4-19
Figure 4-15	Trigger keys .....	4-20
Figure 4-16	Timing without make/break or break/make rows .....	4-22
Figure 4-17	Timing with either make/break or break/make rows .....	4-23
Figure 4-18	Timing with both make/break and break/make rows .....	4-24

## 5 IEEE-488 Programming

Figure 5-1	Flowchart of example program .....	5-2
Figure 5-2	IEEE-488 connector .....	5-3
Figure 5-3	IEEE-488 connections .....	5-3
Figure 5-4	IEEE-488 connector location .....	5-4
Figure 5-5	Contact assignments .....	5-5
Figure 5-6	IEEE-488 indicators .....	5-9
Figure 5-7	LOCAL key .....	5-10
Figure 5-8	External trigger pulse .....	5-16
Figure 5-9	Matrix ready pulse .....	5-17
Figure 5-10	G0 and G1 full output formats .....	5-22
Figure 5-11	G2 and G3 inspect output formats .....	5-23
Figure 5-12	G4 and G5 condensed output formats .....	5-23
Figure 5-13	G6 and G7 binary output formats .....	5-24
Figure 5-14	SRQ mask and serial poll byte format .....	5-28
Figure 5-15	READY and MATRIX READY signal timing .....	5-33
Figure 5-16	U0 machine status word .....	5-35
Figure 5-17	U1 error status word .....	5-35
Figure 5-18	U3 relay step pointer .....	5-36
Figure 5-19	U4 number of slaves .....	5-37
Figure 5-20	U5 card identification .....	5-37
Figure 5-21	U6 relay settling time .....	5-37
Figure 5-22	U7 digital input .....	5-38
Figure 5-23	U8 relay test input .....	5-38

## 6 Principles of Operation

Figure 6-1	Model 707A block diagram .....	6-2
Figure 6-2	Digital board block diagram .....	6-3
Figure 6-3	RAM and battery backup .....	6-5
Figure 6-4	Switching card interface simplified schematic .....	6-7
Figure 6-5	Switching card interface timing diagram .....	6-8
Figure 6-6	Typical switching card logic block diagram .....	6-8
Figure 6-7	IDDATA timing diagram .....	6-9
Figure 6-8	Display board diagram .....	6-11
Figure 6-9	Display interface simplified schematic .....	6-13
Figure 6-10	Light pen interface simplified schematic .....	6-14
Figure 6-11	Master/slave interface simplified schematic .....	6-16
Figure 6-12	Digital I/O interface simplified schematic .....	6-18

## 7 Maintenance

Figure 7-1	Captive nut installation .....	7-3
Figure 7-2	Nut bar on flange .....	7-3
Figure 7-3	Chassis support sizing .....	7-4
Figure 7-4	Chassis support assembly .....	7-4
Figure 7-5	Right side view of disassembly .....	7-5
Figure 7-6	Front view of disassembly .....	7-6
Figure 7-7	Backplane jumpers .....	7-8
Figure 7-8	Troubleshooting programs .....	7-14
Figure 7-9	Relay control waveforms .....	7-15
Figure 7-10	Display interface waveforms .....	7-15

## **B IEEE-488 Bus Overview**

Figure B-1	IEEE-488 bus configuration .....	B-2
Figure B-2	IEEE-488 handshake sequence .....	B-3
Figure B-3	Command codes .....	B-6

# List of Tables

---

## 3 Getting Started

Table 3-1	Row-column and column-column paths .....	3-9
Table 3-2	Matrix and multiplexer cards .....	3-13
Table 3-3	Model 707A external expansion cables .....	3-15
Table 3-4	Response time comparisons .....	3-20
Table 3-5	Model 707A card configuration .....	3-21

## 4 Operation

Table 4-1	Setup data paths .....	4-2
Table 4-2	Power-up, reset, and factory defaults .....	4-3
Table 4-3	Error messages .....	4-5
Table 4-4	Information messages .....	4-6
Table 4-5	Menu operations .....	4-13
Table 4-6	Status of slave unit controls .....	4-17
Table 4-7	Make/break and break/make front panel operation .....	4-20
Table 4-8	Front panel messages for trigger sources .....	4-20

## 5 IEEE-488 Programming

Table 5-1	Sample strings .....	5-2
Table 5-2	Contact assignments .....	5-5
Table 5-3	Model 707A interface function codes .....	5-6
Table 5-4	Basic IEEE-488 statements .....	5-7
Table 5-5	Front panel IEEE-488 error messages .....	5-8
Table 5-6	General bus commands/BASIC statements .....	5-11
Table 5-7	Factory default, power-up, and DCL/SDC conditions .....	5-12
Table 5-8	Order of command execution .....	5-13
Table 5-9	DDC summary .....	5-14
Table 5-10	Master/slave setup example .....	5-21
Table 5-11	Byte counts for data format .....	5-22
Table 5-12	Typical transmission and hold-off times — stand-alone .....	5-44
Table 5-13	Typical transmission and hold-off times — master and one slave .....	5-45

## 6 Principles of Operation

Table 6-1	Display segment assignments .....	6-12
-----------	-----------------------------------	------



## 7 Maintenance

Table 7-1	Line fuse values .....	7-2
Table 7-2	Fixed rack parts .....	7-2
Table 7-3	Recommended troubleshooting equipment .....	7-10
Table 7-4	Power supply checks .....	7-10
Table 7-5	Microcomputer checks .....	7-11
Table 7-6	Relay control checks .....	7-11
Table 7-7	Display interface checks .....	7-12
Table 7-8	Digital I/O checks .....	7-12
Table 7-9	Light pen checks .....	7-13
Table 7-10	Master/slave checks .....	7-13
Table 7-11	Display board checks .....	7-14

## 8 Replaceable Parts

Table 8-1	Digital board assembly .....	8-2
Table 8-2	Display board assembly .....	8-3
Table 8-3	Backplane assembly .....	8-3
Table 8-4	Voltage regulator assembly .....	8-3
Table 8-5	Chassis assembly .....	8-4
Table 8-6	Miscellaneous .....	8-4

## B

Table B-1	IEEE-488 bus command summary .....	B-4
Table B-2	Hexadecimal and decimal command codes .....	B-5
Table B-3	Typical addressed command sequence .....	B-7
Table B-4	Typical common command sequence .....	B-7
Table B-5	IEEE command groups .....	B-7
Table B-6	Model 707A interface function codes .....	B-8

# General Information

---

## 1.1 Introduction

This section contains general information about the Model 707A Switching Matrix. The Model 707A is designed as a programmable switch for connecting signal paths in a matrix topology. It is for applications requiring a large-scale matrix (up to 576 crosspoints per mainframe and 2880 crosspoints per master/slave configuration). Plug-in cards are available for general and special purpose switching applications.

Section 1 is arranged as follows:

### 1.2 Features

### 1.3 Warranty Information

### 1.4 Manual Addenda

### 1.5 Safety Symbols and Terms

### 1.6 Specifications

### 1.7 Unpacking and Inspection

### 1.8 Repacking for Shipment

### 1.9 Optional Accessories

## 1.2 Features

Key features of the Model 707A Switching Matrix include:

- The six-slot mainframe accepts any mix of 8-row by 12-column matrix cards.
- Rows are extended within the mainframe to minimize system wiring and interconnect requirements.
- Storage of 100 sets of relay setups, which can be uploaded or downloaded through the IEEE-488 interface.

- An active front panel LED display shows the current relay status, a stored setup, or an editing scratchpad.
- High-speed triggering of stored setups.
- Make/break and break/make switching are programmable by rows. Operation is transparent to the user and independent of the relay setup.
- With five units connected in a master/slave configuration, the maximum matrix size is eight rows by 360 columns (2880 crosspoints on one IEEE-488 address).
- An optional light pen is available for interactive controlling of relay states, editing stored relay setups, and selecting make/break and break/make rows.

## 1.3 Warranty information


Warranty information is located at the front of this instruction manual. Should your Model 707A require warranty service, contact the Keithley representative or authorized repair facility in your area for further information. When returning the mainframe for repair be sure to fill out and include the service form at the back of this manual to provide the repair facility with the necessary information.


## 1.4 Manual addenda

Any improvements or changes concerning the mainframe or manual will be explained in an addendum included with the unit. Be sure to note these changes and incorporate them into the manual before using or servicing the unit.

## 1.5 Safety symbols and terms

The following symbols and terms may be found on an instrument or used in this manual:

The  symbol on an instrument indicates that the user should refer to the operating instructions located in the instruction manual.

The  symbol on an instrument shows that high voltage may be present on the terminal(s). Use standard safety precautions to avoid personal contact with these voltages.

The **WARNING** heading used in this manual explains dangers that could result in personal injury or death. Always read the associated information very carefully before performing the indicated procedure.

The **CAUTION** heading used in this manual explains hazards that could damage the instrument. Such damage might invalidate the warranty.

## 1.6 Specifications

Model 707A specifications can be found at the front of this manual. These specifications are exclusive of the matrix card specifications, which are located in their appropriate instruction manual.

## 1.7 Unpacking and inspection

### 1.7.1 Inspection for damage

Upon receiving the Model 707A, carefully unpack it from its shipping carton and inspect the unit for any obvious signs of physical damage. Report any damage to the shipping agent immediately. Save the original packing carton for possible future reshipment.

### 1.7.2 Shipment contents

The following items are included with every Model 707A order:

- Model 707A Switching Matrix
- Model 707A Instruction Manual
- Power line cord
- Relay test connector
- Fixed rack mounting hardware
- Additional accessories as ordered

## 1.8 Repacking for shipment

Should it become necessary to return the Model 707A for repair, carefully pack the unit in its original packing carton or the equivalent, and include the following information:

- Call the repair department at 1-800-552-1115 for a Repair Authorization (RMA) number.
- Advise as to the warranty status of the mainframe.
- Write ATTENTION REPAIR DEPARTMENT and the RMA number on the shipping label.
- Fill out and include the service form located at the back of this manual.

## 1.9 Optional accessories

The following accessories are available for the Model 707A:

**Model 7070 Universal Adapter Card** — The Model 7070 card installs in the Model 707A and is jumper-selectable for use either as a backplane extender or a breadboard. It has quick disconnect screw terminals and 10-ft. ribbon cables.

**Model 7071 General Purpose Matrix Card** — The Model 7071 card has 8 rows by 12 columns of 3-pole Form A switching for general purpose applications. It installs in the Model 707A and has mass terminated connectors in addition to quick-disconnect screw terminals.

**Model 7071-4 General Purpose Matrix Card** — The Model 7071-4 card has dual 4 rows by 12 columns of 3-pole Form A, which is also configurable as 8 rows by 12 columns of 3-pole Form A or 4 rows by 24 columns of 3-pole Form A. It installs in the Model 707A and has 38 pin quick disconnect connectors.

**Model 7072 Semiconductor Matrix Card** — The Model 7072 card has 2 rows by 12 columns of 2-pole Form A for low current switching, 4 rows by 12 columns of 2-pole Form A for general purpose switching, and 2 rows by 12 columns of 1-pole Form A for C-V switching. It installs in the Model 707A and has 3-lug triaxial connectors.

**Model 7072-HV Semiconductor Matrix Card** — The Model 7072-HV card has 2 rows by 12 columns of 2-pole Form A for low current paths to jumpers, 4 rows by 12 columns of 2-pole Form A for general purpose paths to the backplane, and 2 rows by 12 columns of 1-pole Form A for C-V paths to jumpers. It installs in the Model 707A and has 3-lug triaxial connectors.

**Model 7073 Coaxial Matrix Card** — The Model 7073 card has 8 rows by 12 columns of 1-pole Form A switching (up to 30MHz) for applications with single-ended instruments. It installs in the Model 707A and has BNC connectors.

**Model 7074-D General Purpose Multiplexer Card** — The Model 7074-D card has eight banks of 1 row by 12 columns of 3-pole Form A. Adjacent banks can be connected together or jumpers can be removed to isolate any bank from the backplane. It installs in the Model 707A and has four 75 pin bank connections and one 38 pin connector for row connections.

**Model 7075 2-Pole Multiplexer Card** — The Model 7075 card has eight banks of 1 row by 12 columns of 2-pole Form A. Adjacent banks can be connected together or jumpers can be removed to isolate any bank from the backplane. It installs in the Model 707A and has nine 25 pin subminiature D connectors, eight for bank connections and one for row connection.

**Model 7076 Dual 2-Pole Matrix Card** — The Model 7076 card has dual 4 rows by 12 columns of 2-pole Form A, which is also configurable as 8 rows by 12 columns of 2-pole Form A. Jumpers can be removed to isolate any bank from the backplane. It installs in the Model 707A and has three 25 pin subminiature D connectors, two for column connection and one for row connection.

**Model 7077 Isolated Coaxial Matrix Card** — The Model 7077 card has 8 rows by 12 columns of 2-pole Form A. It installs in the Model 707A and has BNC connectors.

**Model 7078-DIN 8-pin DIN Cable** — The Model 7078-DIN cable has two 8-pin circular (DIN) connectors and is 1.8m (6 ft.) long. Multiple cables are used for connecting Model 707A units in a master/slave configuration through the rear panel master/slave connectors.

**Model 7078-PEN Programming Light Pen** — The Model 7078-PEN connects to the Model 707A front panel. It is used to toggle the states of crosspoint LEDs, make/break LEDs, and break/make LEDs. A pen holder is included.

**Model 7079 Slide Rack Mounting Kit** — The Model 7079 kit consists of two sets of support brackets, equipment slides, and hardware for mounting the Model 707A in a standard 19-inch equipment rack or cabinet.

**Model 7007 Shielded IEEE-488 Cables** — The Model 7007 connects the Model 707A to the IEEE-488 bus using shielded cables to reduce electromagnetic interference (EMI). The Model 7007-1 is one meter (3.3 ft.) long and has an EMI shielded IEEE-488 connector at each end. The Model 7007-2 cable is identical to the Model 7007-1, but is 2m (6.6 ft.) long.

**Model 7051 BNC to BNC Cables** — The Model 7051 cables are for making connections to External Trigger and Matrix Ready on the Model 707A rear panel. The Model 7051-2 is a 50 $\Omega$  BNC to BNC cable (RG-58C), which is 0.6m (2 ft.) long. The Model 7051-5 cable is identical to the Model 7051-2, but is 1.5m (5 ft.) long.

**Model 7172 Low Current Matrix Card** — The Model 7172 card has 8 rows by 12 columns of 2-pole Form A. Expanding the columns can be done internally by connecting the rows of multiple 7172 cards together with coax jumpers. It installs in the Model 707A and has 3-lug triaxial connectors.

**Model 7173-50 High Frequency 2-Pole Matrix Card** — The Model 7173-50 card has 4 rows by 12 columns of 2-pole Form C with row isolators. It installs in the Model 707A and has BNC connectors.

**Model 7174A Low Current Matrix Card** — The Model 7174A card has 8 rows by 12 columns of 2-pole Form A. Expanding the columns can be done internally by connecting the rows of multiple 7174A cards together with coax jumpers. It installs in the Model 707A and has 3-lug triaxial connectors.

**Model 8000-14 Enclosures** — The Model 8000-14 is a 19"-wide by 14"-high open-backed steel enclosure. It is supplied with hardware to mount a bench-top Model 707A. The top cover of the enclosure can be removed to access jumpers between cards installed in a Model 707A.

# 2

## Card Installation

---

### 2.1 Installing and removing cards

Before operating the Model 707A in a test environment, matrix cards (up to six per mainframe) must be installed into the mainframe. Note that matrix cards are not necessary to program setups. Setups for master/slave configurations can be programmed as long as the MASTER/SLAVE OUT to MASTER/SLAVE IN loop connections are present. (See paragraph 3.5.2.)

#### WARNING

**Before installing/removing cards or making card connections, turn off mainframe power and disconnect the line cord. Also, ensure that no power is applied from the user's circuit.**

Install a card in the Model 707A as follows, using Figure 2-1 as a guide. Instructions specific to each card can be found in the appropriate card manual.

#### CAUTION

**Do not touch the card surfaces, connectors, or components to avoid contamination that could degrade card performance.**

1. Ensure that the access door on top of the mainframe is fully closed and locked down. (The bottom side of the access door has card guides.)

2. Remove the slot cover from the desired slot.
3. With one hand grasping the card's handle, and the other supporting its weight, line up the card with the card guides in the slot. Ensure that the component side is facing the fan of the mainframe.
4. Slide the card into the mainframe until it is fully seated in the backplane connectors. Finger-tighten the spring-loaded mounting screws at the back of the card to lock it in place.

#### WARNING

**The mounting screws must be secured to ensure a proper chassis ground connection between the card and the mainframe. Failure to properly secure this ground connection may result in personal injury or death due to electric shock.**

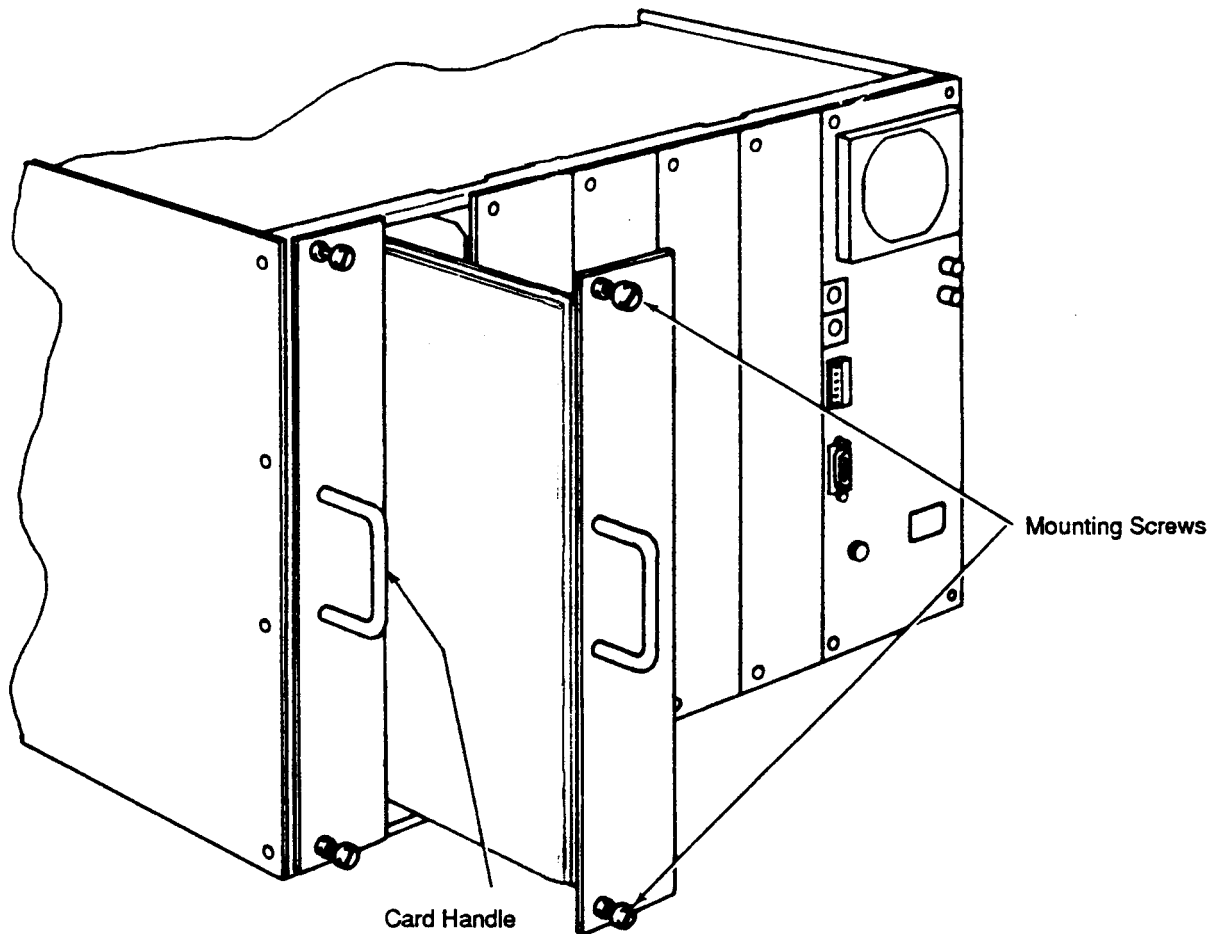
#### NOTE

Some cards have connectors that are inaccessible once the card is fully inserted into the mainframe (e.g., the quick disconnect terminal blocks on Model 7071 cards). In these cases, connect wires to the row and column terminal blocks before seating it in the backplane connectors.

**NOTE**

The SMB coax jumpers used between Model 7072 cards do not have to be installed before the cards are inserted. Use the access door on top of the mainframe for this purpose. (Because of the access door, the Model 7079 slide rack kit is recommended for rack-mounted units.)

5. To remove a matrix card, first turn off the mainframe and disconnect the line cord. Ensure no voltage is applied from the user's circuit. Remove any internal cabling between cards through the unit's access door. Loosen the spring-loaded mounting screws and pull out the card by its handle.



**Figure 2-1**  
*Installing a matrix card*

# 3

## Getting Started

---

### 3.1 Introduction

This section contains introductory information on operating your instrument and is intended to help you get your Model 707A up and running as quickly as possible. It includes a brief description of operating controls and connections. Once you are familiar with the material presented here, refer to Section 4 for more detailed information.

Section 3 is organized as follows:

- 3.2 Front Panel Familiarization:** Briefly describes each front panel control and outlines display operations.
- 3.3 Rear Panel Familiarization:** Outlines each aspect of the Model 707A rear panel, including connectors.
- 3.4 Card Connectors:** Describes where to connect instruments and DUTs to the matrix rows and columns.

**3.5 Expanding Matrix Size:** Discusses methods for expanding the matrix, both internal to the mainframe and with multiple units.

**3.6 Basic Switching Operation:** Provides a general procedure for powering up the Model 707A, choosing make/break or break/make operation, modifying the cross-point display, storing the setup, and sending the setup to the relays.

### 3.2 Front panel familiarization

An overview of the Model 707A operation is given in the following paragraphs. The front panel of the instrument is shown in Figure 3-1. Figure 3-2 illustrates setup data transfers within the Model 707A. This pictorial will be helpful in understanding the operations of individual front panel keys.

All front panel keys except POWER are momentary contact switches. Some keys have an LED to indicate the selected function. The keys are color coded into functional groups for ease of operation.

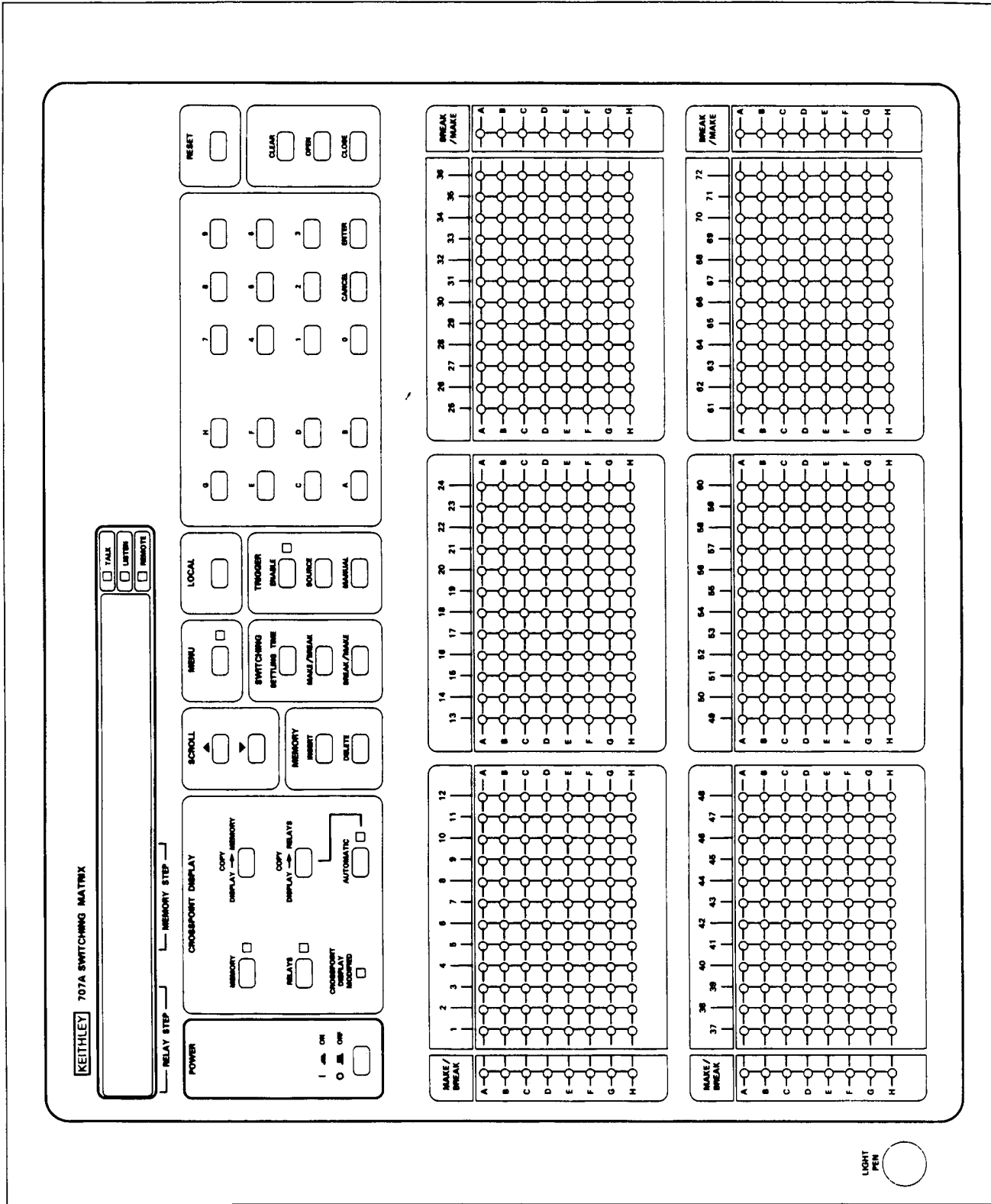
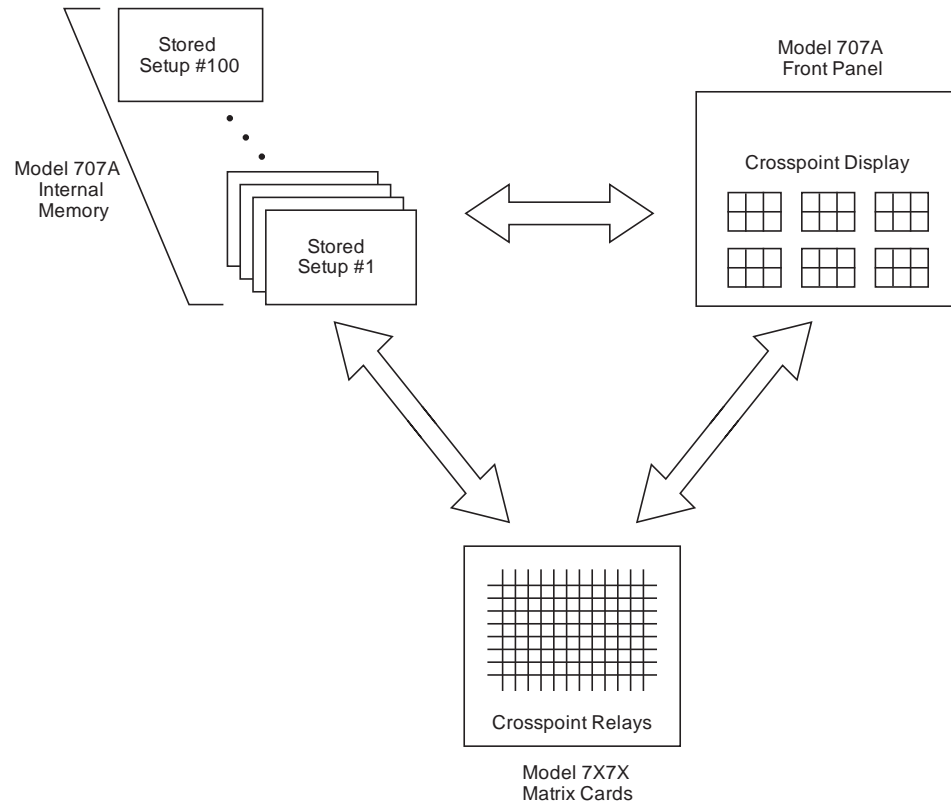


Figure 3-1  
Model 707A front panel





**Figure 3-2**  
*Setup data transfers*

**POWER** — AC power switch turns the unit on or off.

### Crosspoint display group

**MEMORY** — Displays a stored relay setup (from location shown in MEMORY STEP field) on the crosspoint display and lights the MEMORY indicator.

**RELAYS** — Displays the current relay setup on the crosspoint display and lights the RELAYS indicator.

**CROSSPOINT DISPLAY MODIFIED** — Lights when changes are made to the crosspoint display (by front panel keys or light pen), making it different from the original configuration.

**COPY DISPLAY → MEMORY** — Copies the displayed cross-point configuration to the location shown in the MEMORY STEP field.

**COPY DISPLAY → RELAYS** — Copies the displayed cross-point configuration to the relays.

**AUTOMATIC (COPY DISPLAY → RELAYS)** — When this LED is lit, any change to the crosspoint display is sent to the relays at the same time. The pushbutton toggles the LED on and off.

### Scroll group

**SCROLL ▲** — If MEMORY indicator is lit, increments MEMORY STEP field and displays setup on crosspoint LEDs. If RELAYS indicator is lit, increments RELAY STEP field, displays setup on crosspoint LEDs, and sends setup to relays. Also used for scrolling up through a list of multiple choice parameters.

**SCROLL ▼** — Same actions as the SCROLL ▲ key except that it increments and scrolls down.

### Memory group

**INSERT** — Inserts a blank setup at the location shown in the MEMORY STEP field. Moves higher stored setups up one memory location.

**DELETE** — Deletes the setup at the location shown in the MEMORY STEP field. Moves higher stored setups down one memory location.

**MENU** — Steps through the available menu items.

- View digital input, program digital output.
- Select whether rising or falling edge of External Trigger pulse triggers Model 707A.
- Select an active high or active low Matrix ready output signal.
- Select master/slave or stand-alone operation.
- Program IEEE-488 address.
- View longest relay setting time of present card configuration.
- View unit configuration by slot number and card model number.
- Execute self-test.
- Restore factory defaults (and clear stored setups).

Programmable parameters can be changed with the SCROLL or data entry keys and then pressing enter.

### Switching group

**SETTLING TIME** — Displays the current value of programmed settling time. (This delay begins after the relay settling time.) To change the value, enter between 0-65000msec and press ENTER.

**MAKE/BREAK** — Selects rows to operate as make/break (make-before-break) for all setups. First enter row designation (A-H), then press MAKE/BREAK to toggle the state for that row and immediately reprogram the Model 707A for the new operation.

**BREAK/MAKE** — Same action as MAKE/BREAK except that it selects break/make (break-before-make) rows. (Selecting a row for break/make de-selects it for make/break and vice versa.)

**LOCAL** — When in remote (REMOTE on), returns the Model 707A to local mode (REMOTE off). It restores operation of other front panel controls unless LLO (Local Lock-out) is in effect.

**Trigger group**

**ENABLE** — Toggles between triggers enabled and triggers disabled. When triggers are enabled, the LED is lit.

**SOURCE** — Displays current trigger source. Use SCROLL keys to display sources, then press ENTER to select the desired source:

TRIG ON TALK - IEEE talk command  
 TRIG ON GET - IEEE GET command  
 TRIG ON X - IEEE X command  
 TRIG ON EXT - External trigger pulse (rear panel input)  
 TRIG ON KEY - Front panel MANUAL key only

**MANUAL** — Generates a trigger from front panel if triggers are enabled (no matter which trigger source is selected). If the trigger source is TRIG ON KEY, only the MANUAL key generates a trigger.

**DATA ENTRY (A-H, 0-9)** — These keys are for entering row/column addresses and setup locations, selecting make/break and break/make rows, and entering various numeric values.

**CANCEL** — If the value in the alphanumeric display has been modified, this key restores the current parameter value. If the value in the alphanumeric display has not been modified, this key returns the Model 707A to the previous display. CANCEL also exits from menu mode if no changes have been made.

**ENTER** — If the value in the alphanumeric display has been modified, pressing this key stores the parameter value. Also invokes immediate action items from the menu and exits menu mode (except when digital I/O is displayed).

**RESET** — Performs the same functions as cycling power (all relays are opened, triggers are disabled, RELAY STEP to 000, MEMORY STEP to 001, etc.), except powerup self-checking and master/slave loop initialization.

**CLEAR** — Turns off all crosspoint display LEDs. If the AUTOMATIC (COPY DISPLAY → RELAYS) indicator is lit, all relays are opened immediately.

**OPEN** — Turns off crosspoint LED of row/column shown on alphanumeric display. If the AUTOMATIC (COPY DISPLAY → RELAYS) indicator is lit, the corresponding relay opens immediately.

**CLOSE** — Same action as OPEN key except that it turns on the crosspoint LED and relay.

**ALPHANUMERIC DISPLAY** — A 14-character display that can show:

- Error messages.
- Menu item selections.
- Last setup sent from memory to the relays (RELAY STEP field).
- Last setup recalled from memory to the crosspoint display (MEMORY STEP field).
- Trigger source.
- Programmed settling time.
- Alphanumeric key presses (row/column addresses, setup locations).

**IEEE-488 status indicators**

**TALK, LISTEN, REMOTE** — These three LED indicators apply to instrument operation over the IEEE-488 bus. The TALK and LISTEN indicators show when the unit has been addressed to talk or listen. REMOTE turns on to show when the unit is in the IEEE-488 remote state. See Section 4 for detailed information on operation over the bus.

**CROSSPOINT DISPLAY LEDs** — Show open and closed crosspoints of the current relay setup, a stored relay setup, or an edited relay setup. Each LED block of 8 rows by 12 columns shows on/off states of one card. States can be changed by front panel keys, triggers, or optional light pen. Crosspoint configurations can be stored in memory or sent to relays.

**MAKE/BREAK ROW LEDs** — Show which rows are selected for make/break operation. The LEDs can be turned on or off by the MAKE/BREAK, BREAK/MAKE keys or by an optional light pen.

**BREAK/MAKE ROW LEDs** — Same function as MAKE/BREAK row LEDs except for showing which rows are selected for break/make operation. Note that selecting a row for break/make de-selects it for make/break and vice versa.

**LIGHT PEN** — An optional input device for toggling the on/off state of the Crosspoint Display LEDs, MAKE/BREAK row LEDs, and BREAK/MAKE row LEDs. One light pen is used to control the LEDs of up to five Model 707A mainframes.

### 3.3 Rear panel familiarization

An overview of the rear panel of the Model 707A is in the paragraphs that follow. The rear panel is shown in Figure 3-3. In addition to the various connectors, a column locator diagram for a master or stand-alone unit is provided on the rear panel.

**CARD SLOTS** — The Model 707A accepts up to six plug-in matrix cards (8 rows by 12 columns) per mainframe.

**MASTER/SLAVE OUT** — An 8-pin DIN connector for connecting a cable to the next mainframe in a master/slave daisy chain configuration.

**MASTER/SLAVE IN** — An 8-pin DIN connector for connecting a cable from the previous mainframe in a master/slave daisy chain configuration.

**EXTERNAL TRIGGER INPUT** — A BNC jack for applying a trigger pulse to change to the next relay setup, if triggers are enabled and TRIG ON EXT is selected as the source. Pulses must be TTL-compatible, negative-or positive-going (selected by a menu item), with a duration greater than 600nsec.

**MATRIX READY OUTPUT** — A BNC jack providing a TTL-compatible, high- or low-true level (selected by a menu item). It goes false when relays are switched and goes true after the sum of the relay setting time and the programmed settling time.

**RELAY TEST** — A 6-pin quick-disconnect terminal block with logic ground and four logic inputs for testing cross-point relay closures. Wiring between this terminal block and rows A and B of any card in the group of cards to be tested is necessary for the test.

**DIGITAL I/O** — A DB-25 connector for the TTL-compatible digital I/O with data lines for eight inputs and eight outputs. It also contains control lines for handshaking (Input Latch and Output Strobe). Input lines are viewed and output lines are programmed through a menu item.

**IEEE-488 INTERFACE** — This connector interfaces the Model 707A to the IEEE-488 bus. IEEE interface function codes are marked adjacent to the connector.

**AC RECEPTACLE** — Power is applied through the supplied power cord to the 3-terminal AC receptacle.

**LINE FUSE** — The line fuse provides protection for the AC power line input. The fuse rating must match the line voltage setting.

**FAN FILTER** — The fan filter keeps dirt from being drawn into the instrument by the internal cooling fan. The filter should be kept clean to ensure proper instrument cooling.

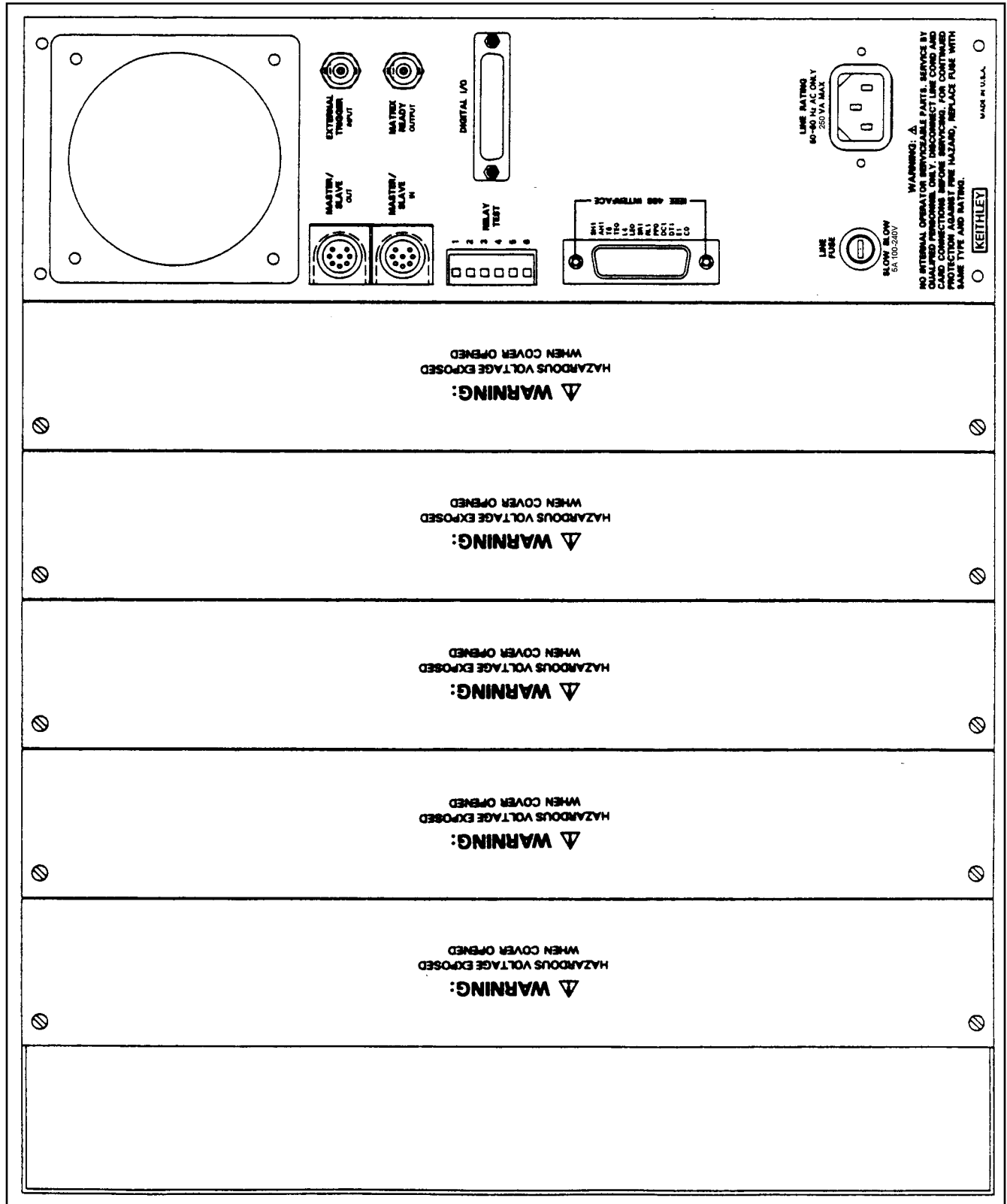
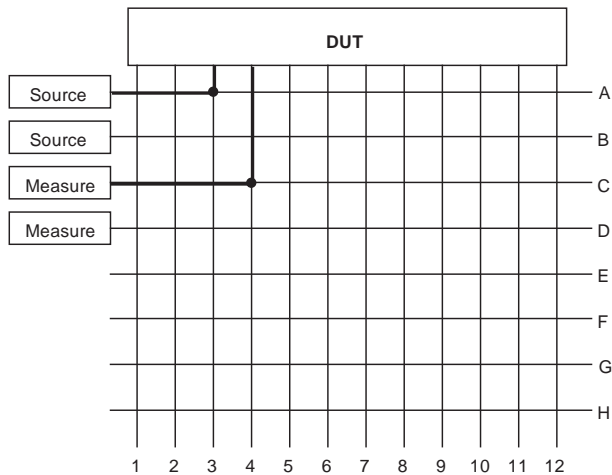


Figure 3-3  
Model 707A rear panel

### 3.4 Card connections

Each card designed for the Model 707A is configured as an 8-row by 12-column matrix. The rows are lengthened by adding columns from other cards (of the same model number). Connections for row expansion are usually internal to the mainframe, either through the analog backplane buses or with user-installed jumpers, depending on the card model. Rows can also be expanded across mainframe boundaries, either in a master/slave or stand-alone/stand-alone configuration. In a master/slave configuration of up to five mainframes, the rows are extended to 360 columns maximum. (Paragraph 3.5 describes master/slave expansion.)

Expansion of rows leads to a long, narrow matrix. If your application requires few instruments and many DUTs, connect the instruments to rows (up to 8) and the DUTs to columns (up to 72 with 6 cards). This connection scheme is optimum because the row-column path has only one crosspoint, as shown in Figure 3-4.



Note : One crosspoint closure yields a row-column path.

**Figure 3-4**  
Connecting instruments to rows

Selecting the row connections for instruments is important with cards designed for multiple applications. Using the Model 7072 as an example, the recommended connections are as follows:

- Rows A and B (low current) — Picoammeters, electrometers.
- Rows C through F (general purpose) — DMMs, sources.
- Rows G and H (C-V characteristics) — C-V analyzers.

An alternate connection scheme of the long, narrow matrix has all connections on the columns, both instruments and DUTs. This is done when the series of tests requires a large number of instruments and DUTs, with only a few signals for each test. As seen in Figure 3-5, with two cards, two crosspoint relays must be closed to complete a path from column-column (a safety benefit when sourcing). Paths with multiple crosspoints have additional path resistance and contact potential than single crosspoint paths.

Crosspoint programming becomes more complex with column-column paths because of the number of possible paths for large matrices and the choice of rows to complete the path. (See Table 3-1.)

The row completion choice for column-column paths on multiple application cards follows the recommendations given previously for row-column paths. That is, with a Model 7072 card, close a crosspoint relay in row A or B for low current applications, row C, D, E, or F for general purpose switching, and row F or G for C-V switching.



### 3.5 Expanding matrix size

The 8-row by 12-column matrix cards of the Model 707A mainframe are building blocks for larger matrices. Matrix expansion is accomplished by two methods:

- Internal to the mainframe — The Model 707A backplane automatically extends rows from other like cards. Special purpose rows (not extended by the backplane) are extended by user-installed jumpers between adjacent cards.
- External to the mainframe — A master/slave connection of up to five mainframes is an extension of the rows (up to 8 rows by 360 columns). Also, individual rows and columns can be connected between cards or between mainframes.

The paragraphs that follow explain matrix expansion in detail.

#### 3.5.1 Single unit expansion

Expansions to a single unit are either connections internal to the mainframe or external connections of the cards in the same mainframe.

#### Internal expansion and isolation

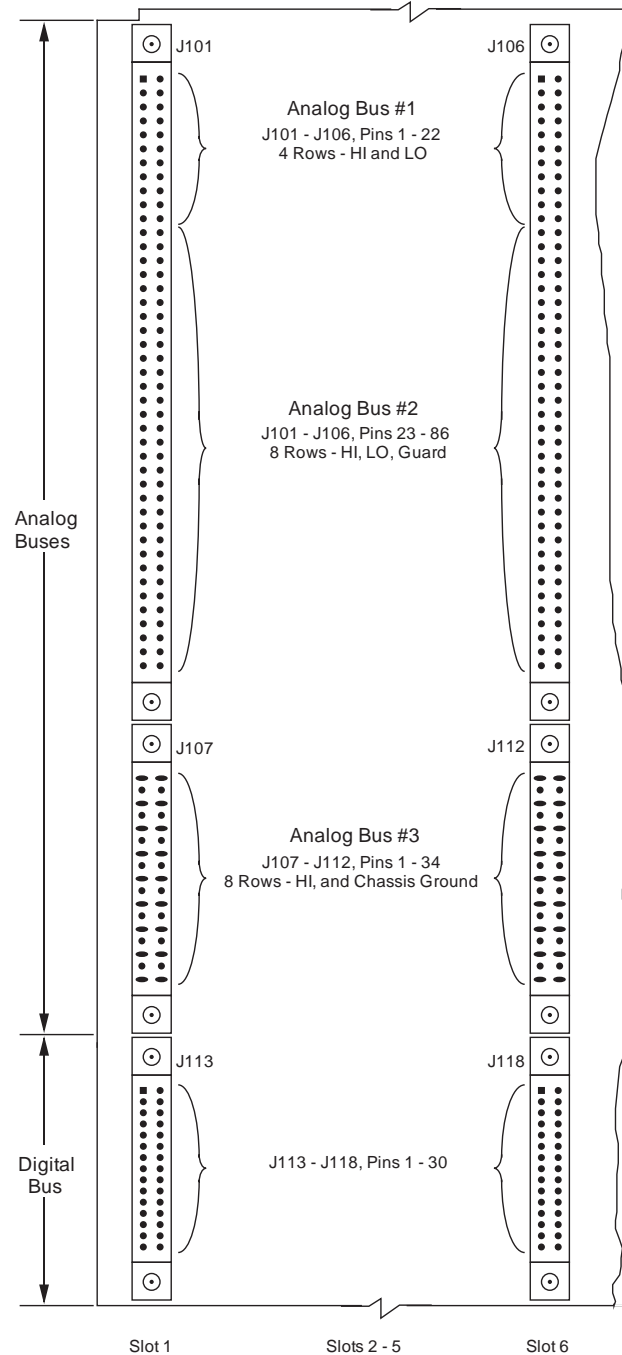
Internal expansion is done automatically through the Model 707A backplane. Each of the six mainframe slots has three card edge connectors, as shown in Figure 3-6 and described below:

- Upper connectors (J101-J106) — Consists of two analog buses (pins 1-22 and pins 23-86) to expand card rows.
- Middle connectors (J107-J112, 34-pin connectors) — Consists of a third analog bus to expand card rows.
- Lower connectors (J113-J118, 30-pin connectors) — This is a digital bus for mainframe control of the matrix cards.

The **first analog bus** expands signals HI and LO of four rows. The LO of an individual row surrounds the HI path and is between the adjacent rows, as shown in Figure 3-7. These rows are used for 2-pole, general purpose switching.

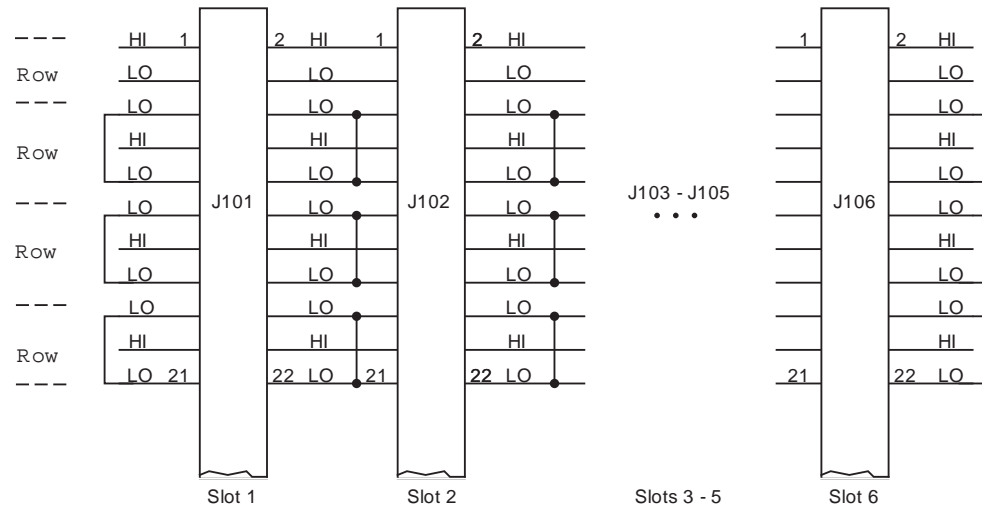
The **second analog bus** expands signals HI, LO, and GUARD of eight rows. The GUARD of each row surrounds the HI and LO paths and separates adjacent rows. See Figure 3-8. These rows are used for 3-pole, general purpose switching and when the guard signal needs to be switched.

The **third analog bus** expands eight rows of a signal HI path and a common ground (chassis). The common ground surrounds the HI path and separates adjacent rows, as shown in Figure 3-9. These rows are for 1-pole switching in common ground (high frequency) systems or floating signals (with an additional row for switching low).

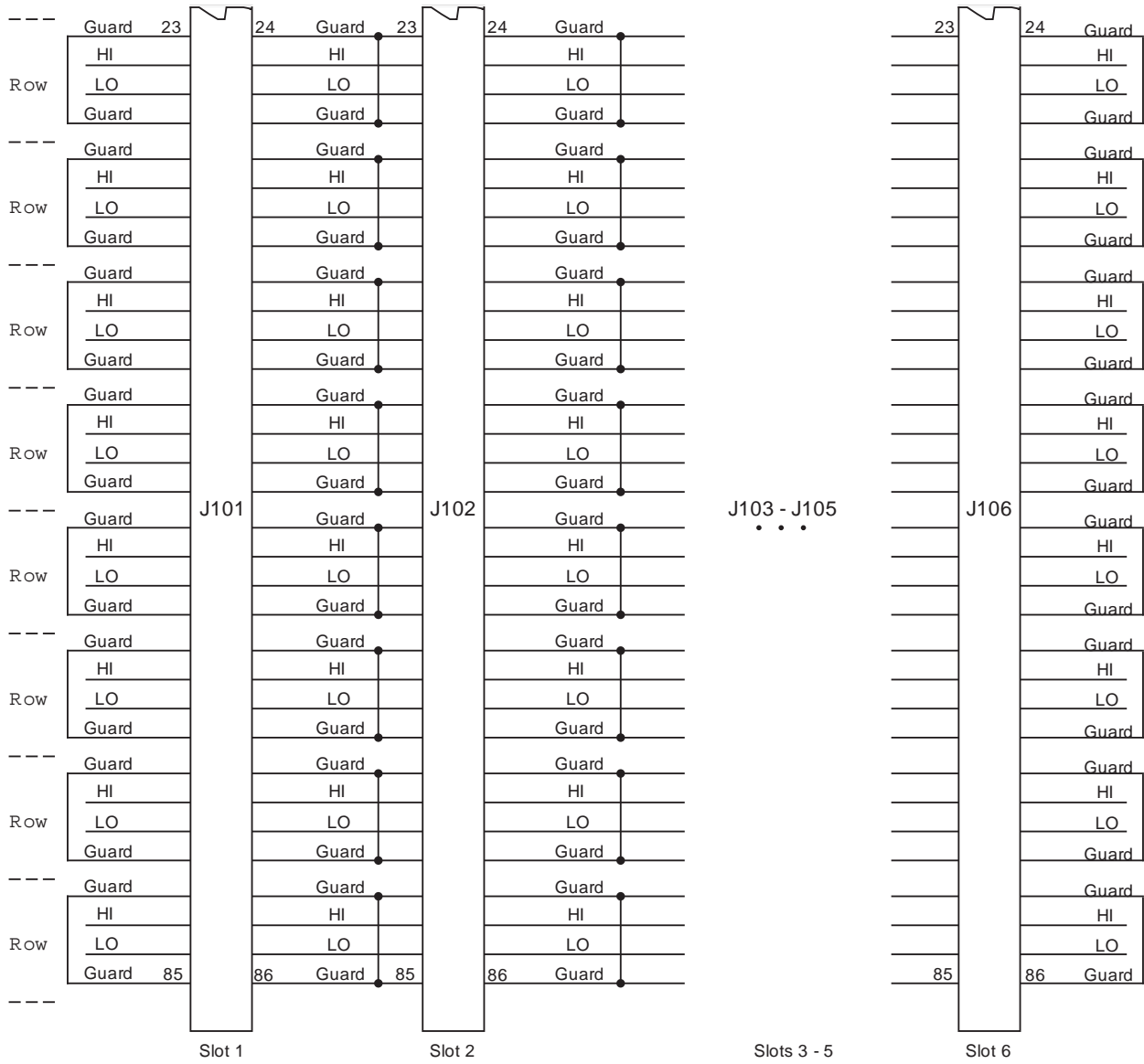


**Figure 3-6**  
Backplane buses

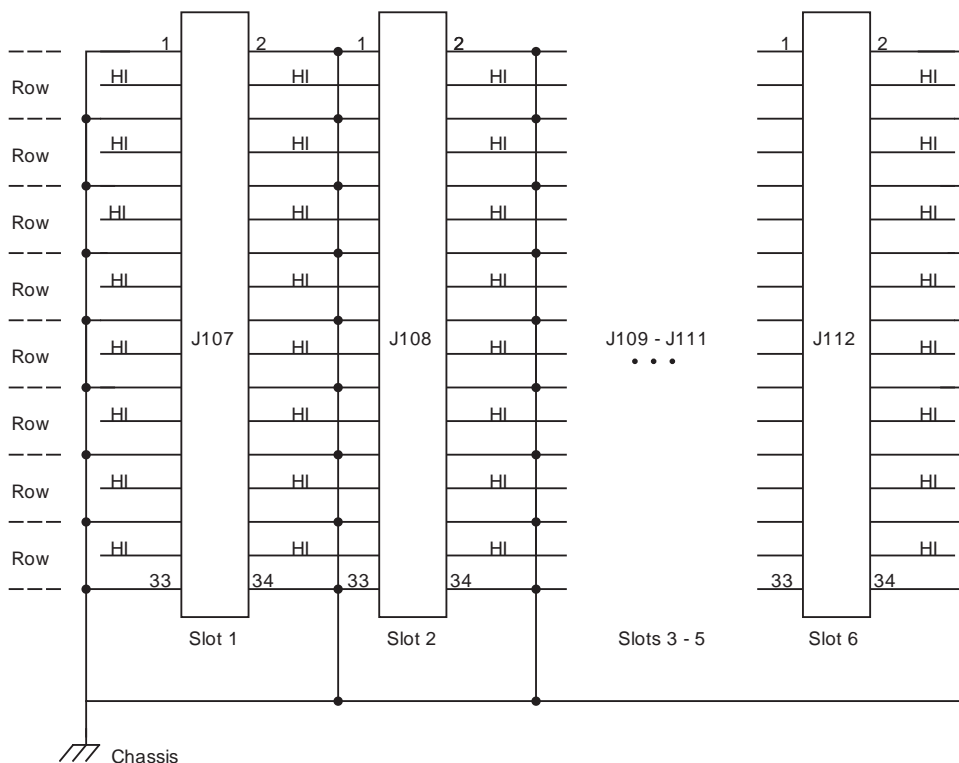




**Figure 3-7**  
Backplane expansion of analog bus #1



**Figure 3-8**  
Backplane expansion of analog bus #2



**Figure 3-9**  
Backplane expansion of analog bus #3

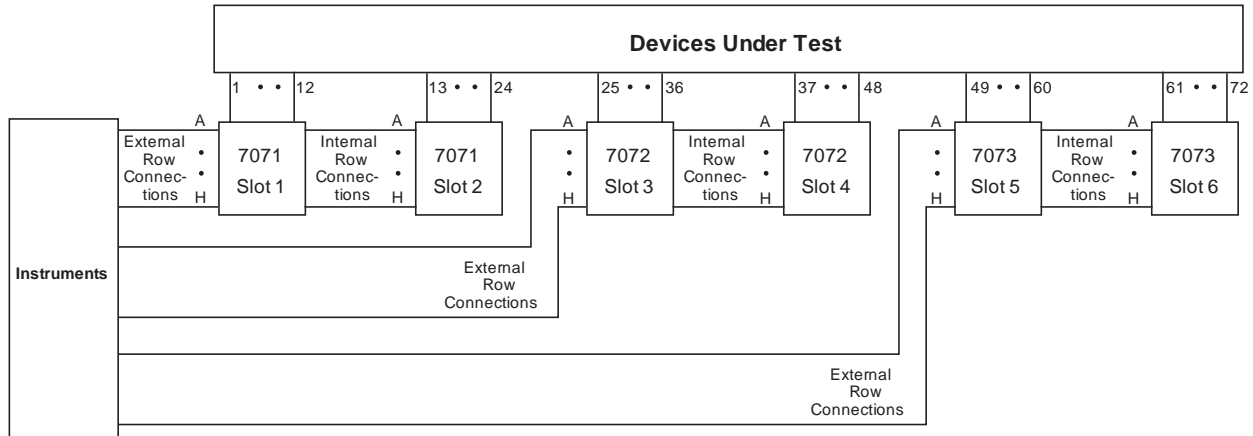
Matrix cards for use in the Model 707A have different edge connectors, depending on the signal path configuration of each card model. The multiplexer cards are summarized in Table 3-2. All cards have a connector for the digital bus.

Note that rows A, B, C, and H of Model 7072 cards, for example, are expanded with SMB coax jumpers between adjacent cards to lessen signal losses of the low current and C-V rows. The jumpers are internal to the mainframe.

When a mainframe contains different card models, instruments must be connected to each card type because of the differing analog bus usage. An example of this is shown in Figure 3-10.

**Table 3-2**  
Matrix and multiplexer cards

Card family	Model	Form
Universal	7070	96 Open Collector Drivers
General purpose	7071	8 × 12 Matrix
	7071-4	Dual 4 × 12 Matrix Card
	7074-D	Eight 1 × 12 Multiplexer Card
	7074-M	Eight 1 × 12 Multiplexer Card
	7075	Eight 1 × 12 Multiplexer Card
Semiconductor	7076	Dual 4 × 12 Matrix Card
	7072	8 × 12 Matrix Card
	7072-HV	8 × 12 Matrix Card
	7172	8 × 12 Matrix Card
Coaxial	7174	8 × 12 Matrix Card
	7073	8 × 12 Matrix Card
	7077	8 × 12 Matrix Card
	7173-50	4 × 12 Matrix Card



**Figure 3-10**  
Row connection examples

In addition to expanding rows in a mainframe, it is also possible to isolate card rows to some extent. There are factory-installed jumpers on the backplane that can be removed to separate the general purpose rows. These jumpers, which are behind the Model 707A front panel, are between slots 3 and 4 of analog bus #1 and analog bus #2. Removing these jumpers effectively separates the mainframe into two 3-slot units. (Jumper removal is described in paragraph 7.6.)

Another isolation method is simply to disconnect the SMB coax jumpers between adjacent Model 7072 cards, for example. These jumpers (for rows A, B, G, and H) are accessed through a door on top of the mainframe.

As an example, jumpers on the Model 7073 card let you selectively expand rows on the backplane to slots on either or both sides, or completely isolate rows from the backplane.

**External expansion**

External expansion within a single mainframe is possible with user-installed wiring between rows and columns of like cards. The available accessory cables for external connections are listed in Table 3-3.

**CAUTION**

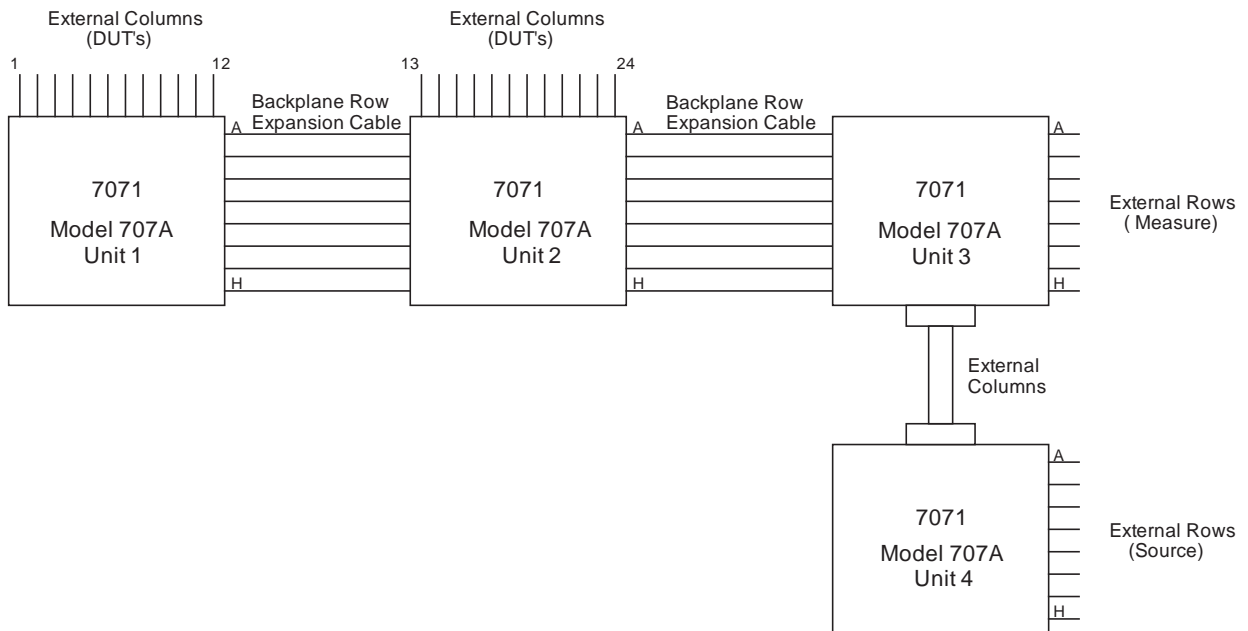
**Connecting dissimilar cards together often degrades performance of both cards. For example, connecting a Model 7072 to a Model 7073 would degrade low current switching on the 7072 and high frequency switching done with the 7073.**

An example of external expansion uses the mainframe as one 6-slot unit and, for some applications, as two 3-slot units. After removing the backplane jumpers, just use external row jumpers between the cards in slots 3 and 4 to select the desired configuration.

External expansion of the cards can also be used to implement a partial matrix. As shown in Figure 3-11 for Model 7071 cards, a column connection is made between the two isolated general purpose backplanes. With the example connections shown, three crosspoints must be closed to source (increasing the safety factor), but only one cross-point closure is needed to measure (recommended for sensitive instruments).

**Table 3-3**  
 Model 707A external expansion cables

Model no.	Description	Expansion
7078-KIT	Mass Terminated Cable Kit	7071, 7071-4 rows/columns, 7074 rows
7078-MTC	Mass Terminated Cable (20 ft.)	
7078-TRX-3	3-lug Triax-Triax Cable (3 ft.)	7072, 7072-HV, 7172, 7174 rows/columns
7078-TRX-10	3-lug Triax-Triax Cable (10 ft.)	
7051-2	BNC-BNC Cable (2 ft.)	7073, 7173-50 rows/columns
7051-5	BNC-BNC Cable (5 ft.)	
7074-KIT	Mass Terminated Cable Kit	7074 banks
7074-MTC	Mass Terminated Cable (20 ft.)	
7075-MTC	Mass Terminated Cable (10 ft.)	7075, 7076 rows/columns



**Figure 3-11**  
 Example of partial matrix expansion

### 3.5.2 Multiple unit expansion

#### Analog expansion

One method to expand a matrix across mainframe boundaries is to connect cards of separate stand-alone units, either by rows or columns. Each unit has a different IEEE-488 bus address and is programmed independently. The additional digital I/O ports are available for programming.

The analog backplane buses can be expanded between separate mainframes. As seen in Figure 3-12, a mass terminated cable can be used to extend Model 7071 card rows (J101-J106, pins 23-86). This configuration of two stand-alone units is an 8-row by 144-column general purpose matrix, with each mainframe programmed independently.

As an example of expansion by columns, consider a 16-row by 72-column matrix of Model 7072 cards. This can be done by connecting all columns of card #1 in one unit to all columns of card #1 in another unit, and so on for all cards. (Triax T-adapters are used in this example to connect instruments or devices to the columns.)

#### Analog expansion and control expansion

Another method of expanding a matrix with multiple mainframes is to connect up to five units in a master/slave configuration. This is done by connecting the rows of like cards in

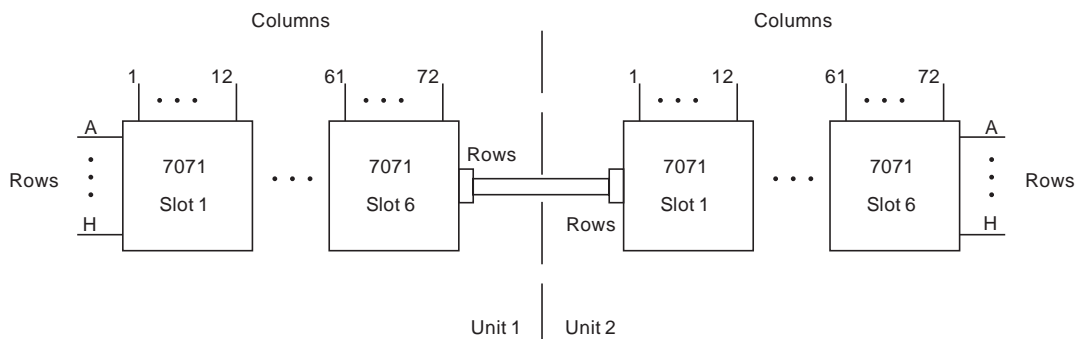
separate units, as shown previously in Figure 3-12, but also by connecting the units in a closed loop of DIN cables for communication and control. A master/slave system configuration appears as one unit with expanded card capacity. That is, only the master unit is addressed by the IEEE-488 bus controller.

A master/slave configuration extends matrix rows yielding a long, narrow matrix. Figure 3-13 shows the connections between two units having Model 7071 cards. With five units, the maximum matrix size is 8 rows by 360 columns. Figure 3-14 shows the column assignments for the maximum configuration.

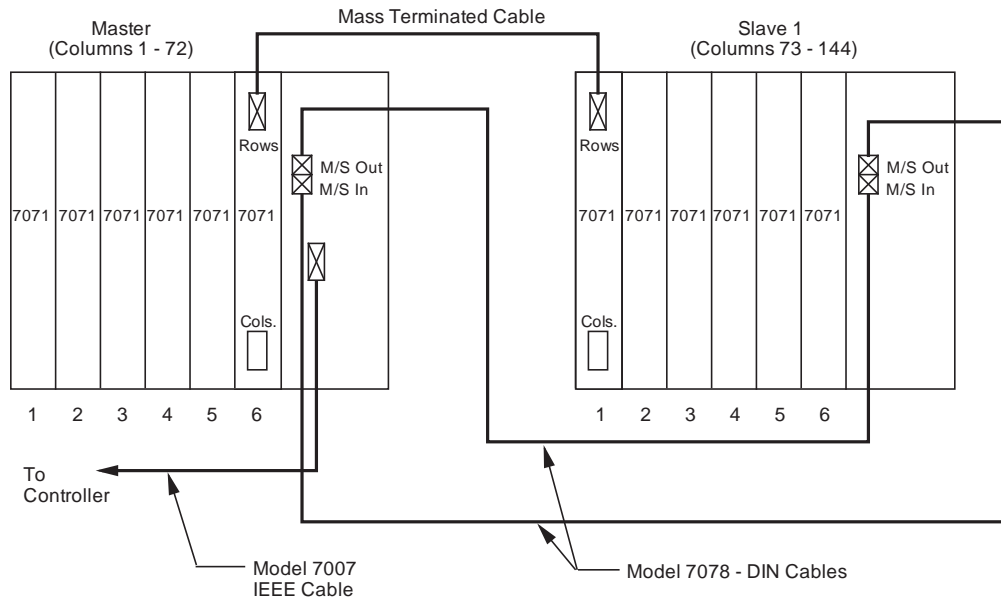
If the mainframes of a master/slave configuration contain different card models, group like cards as much as possible. This will reduce the need to extend the analog buses with external cables.

In some cases, external row expansion is not necessary at all (e.g., one unit only with Model 7071 cards, the second unit only with Model 7072 cards).

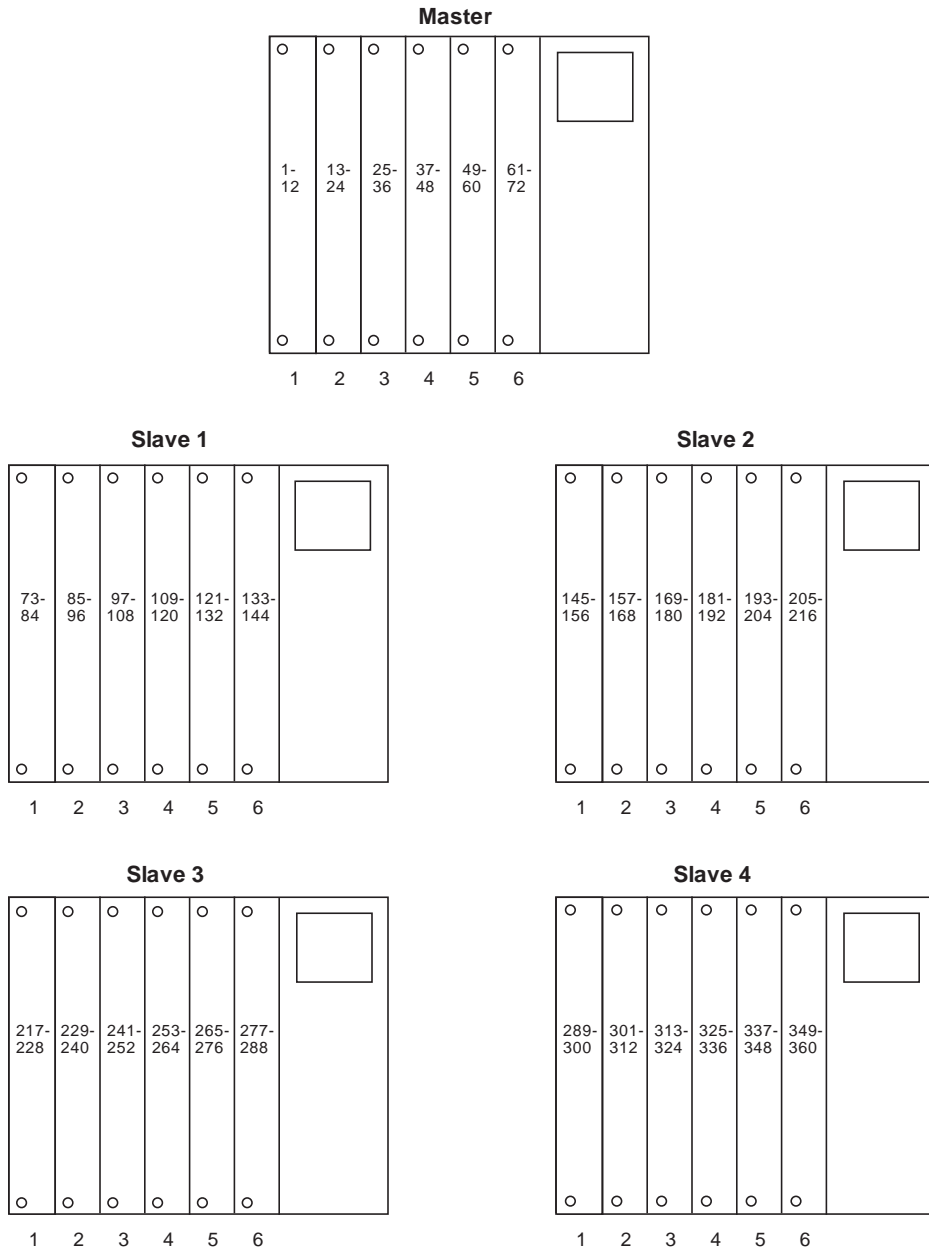
The example of Figure 3-15 shows the row expansion, but not the closed loop of DIN cables for master/slave communication and control. The figure shown is actually three matrices (one 8-row by 72-column and two 8-row by 144-column) that are programmed as one 8-row by 360-column matrix.



**Figure 3-12**  
Model 7071 row connections of stand-alone units



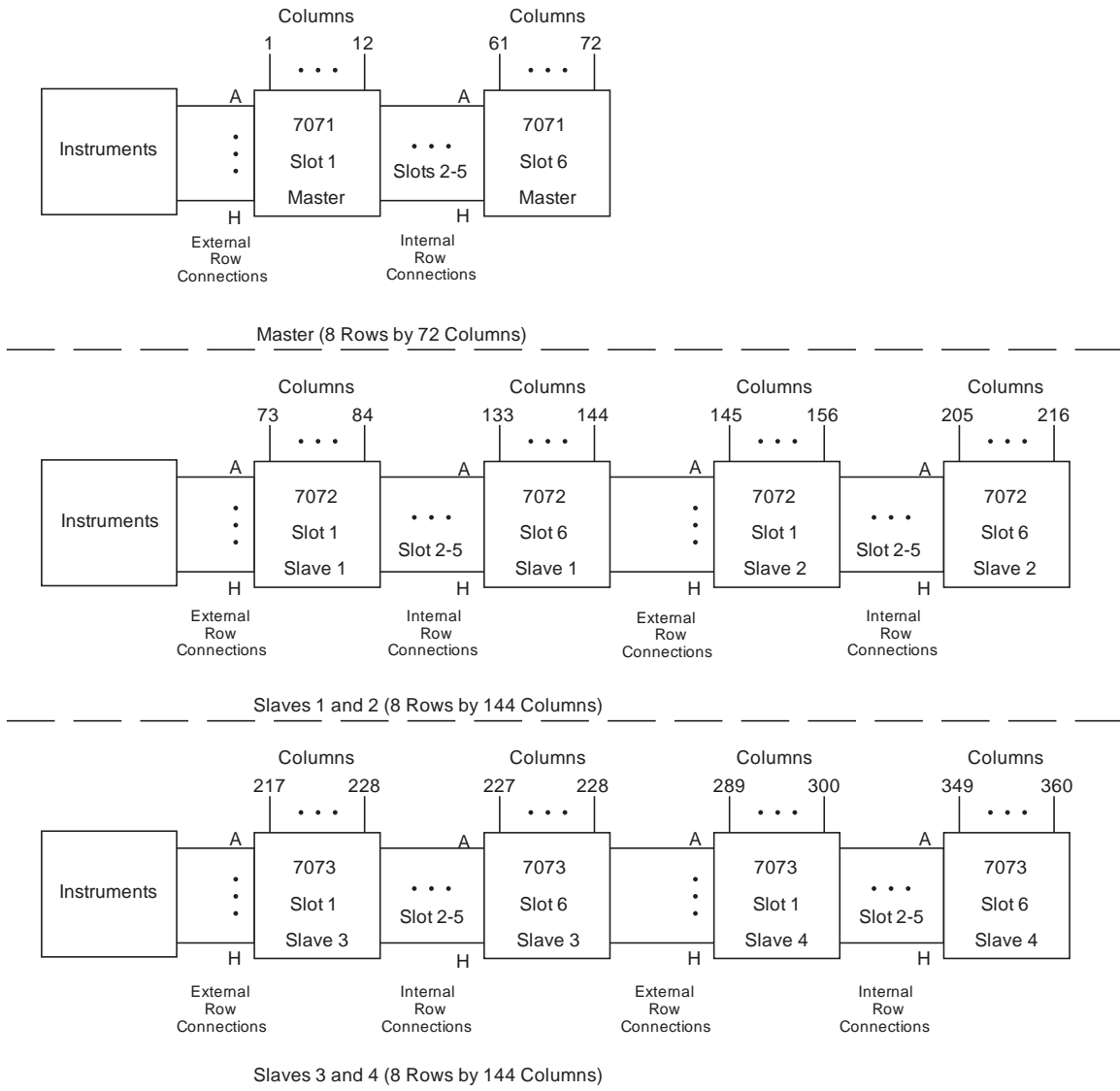
**Figure 3-13**  
 Example of master/slave interconnect cables



**Figure 3-14**  
Master/slave column locations



H



**Figure 3-15**  
Example of master/slave row expansion

### 3.5.3 System expansion issues

Matrix expansion by Model 707A mainframes affects system specifications and speed. The extent depends on the size and configuration of the switching system.

Within a mainframe, internal row expansion decreases isolation among like cards and increases offset current. Isolation relays (on the Model 7072), backplane jumpers (for general purpose rows), and SMB coax jumpers (on the Model 7072) help lessen these effects.

Expansion of units along rows or columns also degrades the isolation and offset current specifications because of the number of parallel paths and relays on each signal line.

There are several issues that affect system speed, among them are:

- Relay settling time — Each matrix card has a pre-defined relay settling time (for example 3msec for the 7071, 15msec for the 7072 and 7073). When card types are mixed in a system, the longest settling time is in effect.
- Bus communication — A master/slave setup responds slower to bus commands because all communication is through the master unit and the data transmission among the units is verified with handshaking. Table 3-4 compares some typical times.

**Table 3-4**

*Response time comparisons*

Action	Stand-alone	Master with 4 slaves
Respond to bus command to close single relay	<15ms	<55ms
Download one setup to 707A	60ms typical	—

### 3.5.4 Documenting system configuration

With the connection flexibility of the matrix topology and the expansion/isolation options of the Model 707A, it is important to document the system configuration.

An example table for tracking card connections and expansion is shown in Table 3-5. Use the top portion of the table to note system operation and size, the FROM/TO portion to list card row and column connections, and the lower portion for notes concerning expansion and operation (e.g., make/break and break/make rows).

**Table 3-5**  
Model 707A card configuration

<b>Slot:</b> _____		<b>Model:</b> _____	
Mainframe: Stand-alone _____			
Master _____		Slave 1 _____	Slave 2 _____
		Slave 3 _____	Slave 4 _____
<b>System size:</b>			
_____ rows _____		columns _____	IEEE address _____
<b>FROM</b> (Instrument connection or DUT pin)	<b>External Card Connection</b>	<b>TO</b> (Instrument connection or DUT pin)	
	<b>Row</b> A		
	B		
	C		
	D		
	E		
	F		
	G		
	H		
	<b>Column</b> 1		
	2		
	3		
	4		
	5		
	6		
	7		
	8		
	9		
	10		
	11		
	12		
<b>Expansion:</b>			
___ Backplane bus (rows through ribbon cable)		___ SMB coax jumpers (rows)	
___ Point to point wiring (rows/cols.)		___ Mass terminated cable (rows/cols.)	
___ BNC coax cable (rows/cols.)		___ Triax cable (rows/cols.)	
<b>Notes:</b>			

## 3.6 Basic switching operation

The following paragraphs will take you through a simple, general, step-by-step procedure to edit a matrix setup, store it in memory, and send the setup to the relays. Although the steps are described with front panel operations, the procedure can be performed over the IEEE-488 bus. (An example program showing this is given in paragraph 5.2.) Even with no instruments or DUTs connected to the matrix cards, the procedure will still have instructional benefits.

See Section 4 for more operation details including master/slave configurations.

### 3.6.1 Power-up

Check that the instrument is set to correspond to the available line voltage. The line voltage switch is located on the rear panel. If the switch is set to the correct position, connect the instrument to a grounded AC outlet using the supplied power cable and turn on the unit.

#### CAUTION

**If the switch setting does not correspond to the available line power, do not change the switch setting and power up the unit as the line fuse will probably blow. Instead, proceed to paragraph 7.2 for the line voltage selection procedure.**

The Model 707A will perform a powerup self-test to check ROM, RAM, card configuration, stored setups, master/slave loop, indicators, and displays. It will then display the software revision level and IEEE-488 bus address.

When the self-test has completed, the Model 707A is configured with:

- All relays opened.
- RELAYS indicator lit (crosspoint display shows current relay setup).
- RELAY STEP to 000 (a pseudo setup memory that is cleared at powerup and sent to the relays).
- MEMORY STEP to 001.

Other powerup defaults are detailed in paragraph 4.3.

### 3.6.2 Selecting make/break and break/make rows

Select make-before-break, break-before-make, or don't care operation for the rows. The selections will be in effect for all relay switching, even if a stored setup is not used. (As a general rule, use make/break operation for current sources and break/make for voltage sources.)

Use the data entry keys to select a row, then press MAKE/BREAK or BREAK/MAKE to toggle the state. (Selecting one state for a row de-selects it for the other.) This operation can also be performed with the light pen by using it to turn on/off the MAKE/BREAK and BREAK/MAKE LEDs.

### 3.6.3 Modifying a relay setup

Perform the following steps to edit a matrix setup.

#### Step 1: Select a stored setup

If you want to modify setup #1, just press the MEMORY key. The MEMORY indicator will light. To select another setup (up to location 100), use the numeric data entry keys (leading zeros are not necessary), then press the MEMORY key.

#### Step 2: Modify the displayed setup

Use the data entry keys to select a crosspoint address (A1 through H72), then press the OPEN or CLOSE key. Key-strokes will be shown on the alphanumeric display and the CROSSPOINT DISPLAY MODIFIED indicator will light.

If you have the optional light pen, toggle the state of a crosspoint LED by holding the light pen perpendicular to and touching the front panel overlay and pressing the light pen button.

Continue editing with the front panel keys or light pen until the crosspoint display shows the desired configuration.

### 3.6.4 Storing setup and sending to relays

The following steps detail front panel operations necessary to store and use the modified setup data.

#### **Step 1: Storing setup in memory**

To store the modified setup at the location shown in the MEMORY STEP field, just press the COPY DISPLAY-MEMORY key. This action overwrites the old setup data at that location with the newly modified setup.

To select a different memory location, key in a valid location number, then press the COPY DISPLAY-MEMORY key. The MEMORY STEP field is set to the new location.

#### **Step 2A: Sending setup to relays**

To make the newly modified setup the current relay setup, just press the COPY DISPLAY-RELAYS key. The relay states will be changed to reflect the modified setup data. If the MEMORY LED is lit, the RELAY STEP field will be set equal to the MEMORY STEP field. In effect, this copies a setup from memory to the relays.

#### **Step 2B: Triggering setup to relays**

If you modified setup #1 and restored it to memory at the same location, a single trigger will copy the setup to the relays. Do this by pressing the trigger SOURCE key, scrolling to the “TRIG ON KEY” display and pressing ENTER. Then press the trigger ENABLE key. Pressing the trigger MANUAL key will copy setup #1 to the relays and set the RELAY STEP field to 001.

# 4

## Operation

### 4.1 Introduction

This section contains a complete, detailed description of each front and rear panel aspect of the Model 707A. The section is arranged as follows:

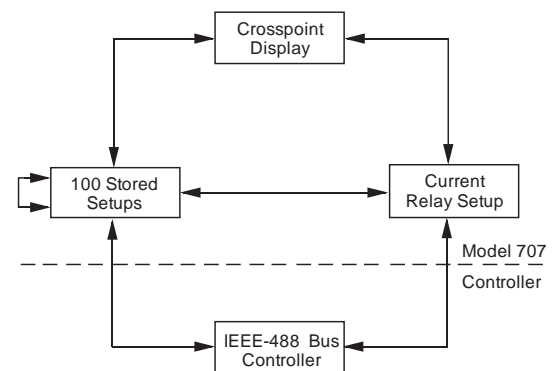
- 4.2 Setup Data Paths:** Describes the paths for setup data within a Model 707A and to/from a bus controller.
- 4.3 Power-up Procedure:** Details how to connect the instrument to line power and turn it on, including power-up self-test and default conditions.
- 4.4 Displays and Messages:** Covers the uses of the alphanumeric display, crosspoint display, and make/break and break/make row LEDs. Also lists display messages that may be encountered during front panel operations.
- 4.5 Selecting Crosspoint Display:** Describes how to select the source of relay setup data (current relay setup or a stored setup).
- 4.6 Modifying Crosspoint Display:** Discusses the operations to open/close crosspoint display LEDs.
- 4.7 Copying Crosspoint Display:** Describes copying a display to the relays and to memory.
- 4.8 Inserting and Deleting Stored Setups:** Covers how to insert a blank setup in memory and how to delete a stored setup from memory.
- 4.9 Menu Operations:** Details menu item selection and operation, including digital I/O, external trigger, matrix ready, master/slave, IEEE-488 bus address, relay settling time, card identification, self-test, and factory defaults.
- 4.10 Selecting Switching Parameters:** Covers the programmed settling time and make/break, break/make operations.
- 4.11 Triggering:** Details selecting the trigger source and describes the operation of the rear panel trigger input and output jacks.

- 4.12 Resetting:** Discusses the reset operation of the Model 707A.

### 4.2 Setup data paths

The design of the Model 707A is optimized for high speed switching of relay setups for matrices with a maximum of 8 rows by 72 columns (one unit) to 8 rows by 360 columns (five units). If no rows are selected for make/break or break/make operation, previously stored setups can be switched to the relays at a rate of up to 200 setups per second.

Besides the triggering of stored setup data to the relays, setup data can be routed to/from the sources and destinations shown in Figure 4-1. The data paths are selected by the front panel or IEEE-488 bus operations listed in Table 4-1.



**Figure 4-1**  
*Paths for relay setup data*

In addition to other front and rear panel operations, this section describes setup data transfers that are performed from the Model 707A front panel. Section 5 will describe the bus operations that transfer setup data.

**Table 4-1**

Setup data paths

Setup data path	Action required
Display-Memory Display-Relays	Front panel keystroke Front panel keystroke or an automatic copy (Note 1)
Memory-Display	Front panel keystroke or an automatic operation (Note 2)
Memory-Relays	Bus command or any valid trigger
Memory-Controller	Bus command
Memory-Memory	Bus command
Relays-Display	Front panel keystroke or an automatic operation (Note 3)
Relays - Memory	Bus command
Relays-Controller	Bus command
Controller-Memory	Bus command
Controller-Relays	Bus command

Notes:

1. Generation of the automatic copy is selected by a front panel key. (AUTOMATIC LED is lit.)
2. The automatic operation is generated if the displayed setup has been changed by a bus command and has not been modified from the front panel. (MEMORY LED is lit.)
3. The automatic operation is generated if the displayed setup has been changed by a trigger or bus command and has not been modified from the front panel. (RELAYS LED is lit.)
4. Controller modifications to setups are reflected on the crosspoint display if the affected setup is currently being displayed.
5. Front panel keystrokes can be generated by bus commands.

### 4.3 Power-up procedure

The steps in the following paragraphs take you through the basic procedures for selecting the line voltage, connecting the instrument to line power, and turning on the instrument.

#### 4.3.1 Line voltage selection

The Model 707A operates from a line voltage in the range of 100 to 240V, at a frequency of 50 or 60Hz. Line voltage and frequency are automatically sensed, therefore there are no switches to set. Check to see that the line power in your area is compatible.

#### 4.3.2 Line power connections

Using the supplied power cord, connect the instrument to an appropriate 50 or 60Hz ac power source. The female end of the cord connects to the ac receptacle on the rear panel of the instrument. The other end of the cord should be connected to a grounded ac outlet.

### WARNING

**The Model 707A must be connected to a grounded outlet to maintain continued protection against possible shock hazards. Failure to use a grounded outlet may result in personal injury or death due to electric shock.**

#### 4.3.3 Power switch

To turn on the power, simply push in the front panel POWER switch. Power is on when the switch is at the inner (1) position. To turn power off, press POWER a second time.

#### 4.3.4 Power-up self-test and messages

During the power-up cycle, the instrument performs the following tests. The first five operations are transparent to the user unless an error occurs.

1. A checksum test is performed on ROM and a read/write test on RAM. If an error is found, the self-test continues and the unit displays either ROM FAIL or RAM FAIL when the test has completed. You can override either type of error with a front panel keypress. The Model 707A will attempt normal operation.

### NOTE

If a problem develops while the instrument is still under warranty (less than one year from shipment date), return it to Keithley Instruments, Inc. for repair. For units out of warranty refer to Section 6, Maintenance.

2. The Model 707A reads identity information from each card and performs a checksum test on the data. If the checksum test fails on one or more matrix cards, the instrument displays CARD ID ERROR and lights all crosspoint LEDs of that card. Any keypress will allow the unit to continue. An empty slot will not produce an error.
3. A checksum test is performed on all setups in memory. If the instrument detects a checksum error in one or more stored setups, it displays the message SETUP ERROR and clears the crosspoints bits of the setup(s) in error. The message remains displayed until a key is pressed.

### NOTE

The SETUP ERROR message may be an indication of a low battery. Cycle power off and on. If the message reappears, see paragraph 7.7 for battery replacement procedure.

4. The present card configuration (i.e., which cards are installed in which slots) is compared with the unit's previous configuration. If there is a change, the 100 setups in memory are reformatted. (The front panel display is blanked out during this time.) Crosspoint closures are not affected, just the way a setup is stored for the different cards.
5. If the unit was previously programmed as a stand-alone or slave unit, it powers up as a stand-alone. If the unit was programmed as a master the last time it was on, it checks for additional units in a serial looped configuration and tries to make them slave units. (Refer to paragraph 4.3.6 for information concerning turning on a master/slave configuration.)  
The message M/S ERROR is displayed if there is not a closed loop (the Model 707A can be looped back to itself). Any keypress or IEEE-488 bus operation will allow the unit to continue as a stand-alone unit.
6. The instrument performs the display test, where it lights all segments of the alphanumeric display, all crosspoint LEDs, and all other LED indicators. Then it briefly displays the software revision level and the programmed primary IEEE-488 address as in this example:

A01 IEEE 18

Knowing the software revision level is useful when discussing problems with Keithley Instruments. In this example, the factory default primary IEEE-488 address is displayed. The actual address depends on the programmed value.

### 4.3.5 Power-up configuration

After the power-up tests and display messages are completed, the Model 707A assumes specific operating states:

- All relays are opened.
- The RELAYS indicator is lit (crosspoint display shows current relay setup).
- The RELAY STEP field is set to 000 and the MEMORY STEP field is set to 001.
- Trigger disabled.

Table 4-2 summarizes the power-up configuration for the unit. The entire power-up process takes approximately five seconds to complete.

**Table 4-2**  
*Power-up, reset, and factory defaults*

Parameter	Power-up/reset default	Factory default
Relays	All opened	All opened
Stored setups	Unchanged	All cleared
RELAY STEP	000	000
MEMORY STEP	001	001
Digital output	000	000
External trigger	Falling edge	Falling edge
Matrix ready	Active low	Active low
Master/slave	Unchanged (if successful)	Unchanged
IEEE-488 address	Unchanged	18
Programmed settling time	0msec	0msec
Make/break rows	Unchanged	None selected
Break/make rows	Unchanged	None selected
Trigger enable	Disabled	Disabled
Trigger source	External	External



### 4.3.6 Master/slave power-up

The power-up sequence for Model 707A mainframes can be summarized as follows:

Each unit connected in the master/slave loop displays M/S LOOP DOWN until all units are powered up.

- Units previously programmed as stand-alones or slaves power up as stand-alones.
- A unit previously programmed as a master powers up as a master and tries to initiate a loop connection. If it is successful, other units in the loop become slaves. If it is not successful, the message M/S ERROR is displayed and the unit reverts to stand-alone operation.

To connect and power up a master/slave configuration for the first time, follow these steps:

1. Connect up to five mainframes in a daisy chain (Master/Slave Out of one unit to Master/Slave In of next unit) as previously shown in Figure 3-14 for two units.
2. Power up each unit. Since there is no master in the loop as yet, all units will power up as stand-alones. The units will display the message M/S LOOP DOWN until all are turned on.
3. From the front panel of the desired master unit, press the MENU key until the alphanumeric display shows:

STANDALONE

Press one of the SCROLL keys to change the display to MASTER, then press ENTER. This action initiates a loop connection, making this unit the master and the other units slaves, and exits menu mode.

During subsequent power-ups of master/slave configurations, all connected mainframes wait for all units to get

power before initializing. Thus, it is not necessary to turn on the master unit last.

#### CAUTION

**When it is necessary to cycle power on a slave unit, turn off all units in the master/slave configuration. This procedure prevents the open communication and control loop from putting the slave unit in an undesirable state.**

## 4.4 Displays and messages

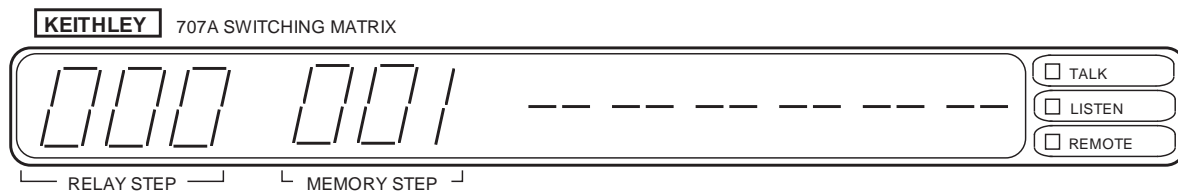
### 4.4.1 Alphanumeric display

The alphanumeric display is a 14-character display that can show error messages, informational messages (e.g., menu item parameters), last setup sent to relays, last setup recalled to crosspoint display, trigger source, programmed settling time, and alphanumeric key presses. See Figure 4-2.

The 3-digit RELAY STEP field of the alphanumeric display shows the location of the last setup sent from memory to the relays. A trigger causes the next setup (RELAY STEP +1) to be sent to the relays.

The 3-digit MEMORY STEP field of the alphanumeric display shows the location of the last setup recalled from memory to the crosspoint display.

The 6-digit data entry scratchpad field reflects alphanumeric key presses by the user, such as row and column addresses and setup locations.



**Figure 4-2**  
Alphanumeric display

## 4.4.2 Display messages

During Model 707A operation and programming, you will encounter a number of front panel messages on the alphanumeric display. Typical messages will be either of error or informational variety, as discussed in the following paragraphs.

### Error Messages

Error messages are divided into two categories: those which stay on the display until a keypress or some other operation changes the display, and those which appear for two seconds and then the display returns to its previous state.

**Table 4-3**

*Error messages*

Message	Description	Corrective Action
CARD ID ERROR*	Checksum test failed on one or more matrix cards.	Remove card identified by all crosspoint LEDs lit.
IDDC	Invalid device-dependent command.	Send only valid commands (see Section 5).
IDDCO	Invalid device-dependent command option.	Send only valid command options (see Section 5).
INVALID INPUT	Invalid crosspoint address, setup location, make/break or break/make row, or parameter out of range.	Enter valid data.
LIGHT PEN????	Light pen button pressed when pen was not pointed at crosspoint LED or make/break or break/make LED.	Press button with pen perpendicular to LED.
M/S ERROR*	Error in master/slave communication loop (over-run, parity, framing, count imbalance, or time-out).	Check for a closed loop of MASTER/SLAVE OUT to MASTER/SLAVE IN.
M/S LOOP DOWN	One or more units connected in master/slave loop are not powered up.	Turn on all units or reconfigure master/slave loop. Put Model 707A in remote.
NOT IN REMOTE	“X” character received over IEEE-488 bus but Model 707A is not in remote.	See troubleshooting in Section 7.
RAM FAIL*	Self-test detected error in RAM.	See troubleshooting in Section 7.
ROM FAIL*	Self-test detected checksum error in ROM.	Affected setup is cleared, then Model 707A proceeds normally.
SETUP ERROR*	Self-test detected checksum error in stored setup. Battery may be low.	Check the READY bit in the serial poll byte.
TRIG OVERRUN	An additional trigger was received before the Model 707A asserts the READY signal.	

\* Message remains displayed until next operation.

Table 4-3 lists Model 707A error messages. Many of these messages are also covered in pertinent paragraphs of the manual. Where applicable, the necessary corrective action is also given in the table.

### Informational messages

Informational messages are included as a programming aid. No corrective action is necessary, but you still may be required to enter a parameter at the prompt. Table 4-4 lists Model 707A informational messages. Again, most of these are covered in other parts of the manual.

**Table 4-4**  
Information messages

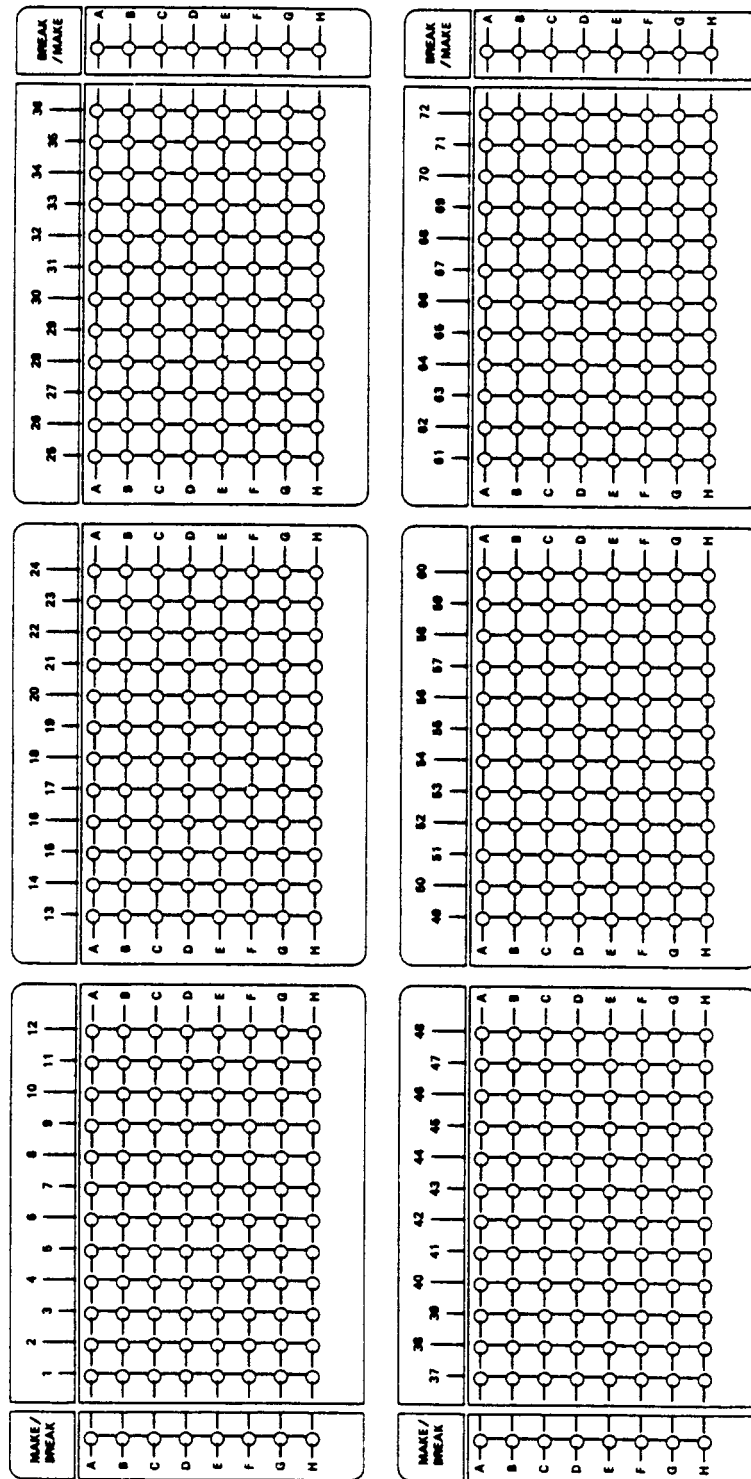
Message	Key(s)	Description
IN 255 OUT 000	MENU	Digital input status and digital output parameter (decimal values).
EXT TRIG FALL	MENU	Falling edge external trigger pulse.
EXT TRIG RISE	MENU	Rising edge external trigger pulse.
MATRIX RDY LO	MENU	Matrix Ready pulse active low.
MATRIX RDY HI	MENU	Matrix Ready pulse active high.
STANDALONE	MENU	Stand-alone operation of Model 707A.
MASTER	MENU	Master unit in master/slave configuration.
IEEE-488 18	MENU	IEEE-488 bus address of 18.
HWSETL 015 mS	MENU	Longest relay settling time of present card configuration (Model 7073 is shown).
1 7071	MENU	Card configuration by slot and model number (Model 7071 in slot 1 is shown).
SELF TEST	MENU	Item to select self-test execution.
FACTORY INIT	MENU	Item to select factory defaults (setups cleared).
SETL 00000 mS	SETTLING TIME	Programmed settling time (added to relay settling time).
TRIG ON EXT	SOURCE	External trigger pulse triggering.
TRIG ON KEY	SOURCE	Front panel key triggering.
TRIG ON TALK	SOURCE	IEEE talk command triggering.
TRIG ON GET	SOURCE	IEEE GET command triggering.
TRIG ON X	SOURCE	IEEE X command triggering.
NOT SETTLED	—	Additional trigger received before programmed settling time expired (trigger is processed).

#### 4.4.3 IEEE-488 status indicators

The TALK, LISTEN, and REMOTE LEDs (shown in Figure 4-2) indicate these modes when the Model 707A is being programmed over the IEEE-488 bus. The TALK and LISTEN indicators show when the unit has been addressed to talk or listen. These talk and listen commands are derived from the unit's primary address. REMOTE turns on to show when the unit is placed in remote by addressing it to listen with the REN line true. (All front panel controls except LOCAL and POWER are inoperative when REMOTE is on.) Local operation is restored by pressing LOCAL unless the IEEE-488 LLO (Local Lockout) command is in effect. See Section 5 for details of IEEE-488 bus operation.

#### 4.4.4 Crosspoint display LEDs

As shown in Figure 4-3, the crosspoint display has six blocks of LEDs (one per card slot). Each block has 8 rows (A-H) by 12 columns (1-12, 13-24, etc.) of LEDs. The display LEDs can show the current open/closed relay states, the on/off states of a setup from in memory, or the on/off states of a setup currently being edited. The on/off states of crosspoint LEDs can be changed by front panel keys, commands over the bus, or an optional light pen. Modified displays can be stored in memory or sent to the relays.



**Figure 4-3**  
Crosspoint display

#### 4.4.5 Make/break and break/make LEDs

The MAKE/BREAK and BREAK/MAKE displays each have two blocks of LEDs labeled A-H (one for columns 1-36, the other for columns 37-72). Refer to Figure 4-3. Each block shows which rows have been selected for make/break or break/make operation. When switching current sources, use make/break operation to keep current flowing and eliminate switching transients. When switching voltage sources, use break/make operation to avoid momentary shorting of two paths together.

The LEDs can be turned on or off by pressing a row letter key and the MAKE/BREAK or BREAK/MAKE key, or with an optional light pen. Note that selecting a row for break/make de-selects it for make/break and vice versa.

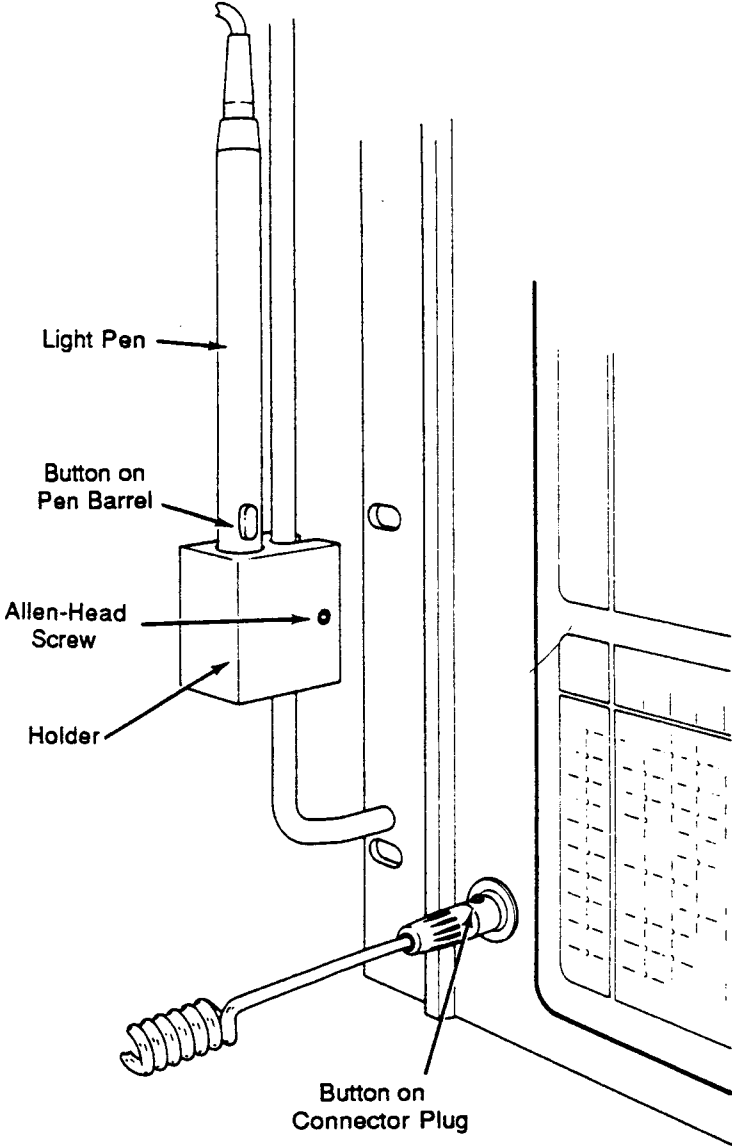
#### 4.4.6 Light pen

The light pen is an optional input device for toggling the on/off states of crosspoint display LEDs, MAKE/BREAK row LEDs, and BREAK/MAKE row LEDs. One light pen is used to control the LEDs of all units in a master/slave system.

As seen in Figure 4-4, the light pen plugs into the front panel of stand-alone or master units. Remove the light pen by pressing the button on the connector plug while pulling out the plug. Mount the light pen holder on the left handle of the Model 707A by tightening the allen-head screw shown in Figure 4-4.

To toggle the state of a crosspoint LED or MAKE/BREAK, BREAK/MAKE LED with the light pen, follow these steps:

1. Hold the light pen as you would an ordinary pen.
2. With the light pen perpendicular to the front panel overlay at the desired LED, press the button on the pen's barrel.
3. Proper usage will toggle the state of the LED. If the button is pressed while not on an LED, the message LIGHT PEN???? is displayed briefly, then the Model 707A reverts to its previous display.

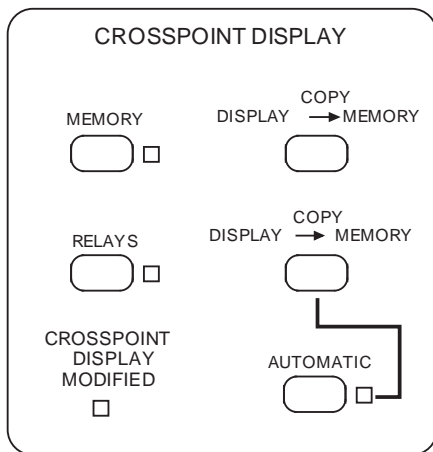


**Figure 4-4**  
*Light pen*

## 4.5 Selecting crosspoint display

In the CROSSPOINT DISPLAY key group on the front panel are two keys that are used to bring setups to the crosspoint display. See Figure 4-5. Three LEDs in the group indicate the source of setup data. Only one of these LEDs is lit at a time:

- MEMORY LED — When lit, the crosspoint display shows a setup stored in memory.
- RELAYS LED — When lit, the crosspoint display shows the current relay setup.
- CROSSPOINT DISPLAY MODIFIED LED — When lit, the crosspoint display shows a modified setup that was previously from memory or from the relays.



**Figure 4-5**  
Crosspoint display keys

Pressing the MEMORY key displays a stored relay setup (location shown in MEMORY STEP field) on the crosspoint display and lights the MEMORY indicator. If a valid location (1400) is entered first from the data entry keypad, that setup is displayed on the crosspoints and in the MEMORY STEP field. (The INVALID INPUT message is displayed briefly for locations out of range.) The CANCEL key can be used to remove incorrect entries from the alphanumeric display.

When the MEMORY indicator is lit, a setup can also be displayed by entering a valid location and pressing ENTER, or by pressing a SCROLL key to display the setup at MEMORY STEP ±1. If you press and hold a SCROLL key, the MEMORY STEP field is updated continuously. As location 000 is invalid for MEMORY STEP, the SCROLL keys skip this location when incrementing or decrementing.

If the displayed setup is modified by IEEE-488 commands, the crosspoint display changes if the MEMORY indicator is lit. In other words, if you are editing a setup, changes to its source do not appear.

Pressing the RELAYS key displays the current relay setup on the crosspoint display and lights the RELAYS indicator. If a valid location (0400) is entered first, that setup is sent to the relays and displayed on the crosspoints and in the RELAY STEP field. When location 000 is selected in this manner, the relay states do not change.

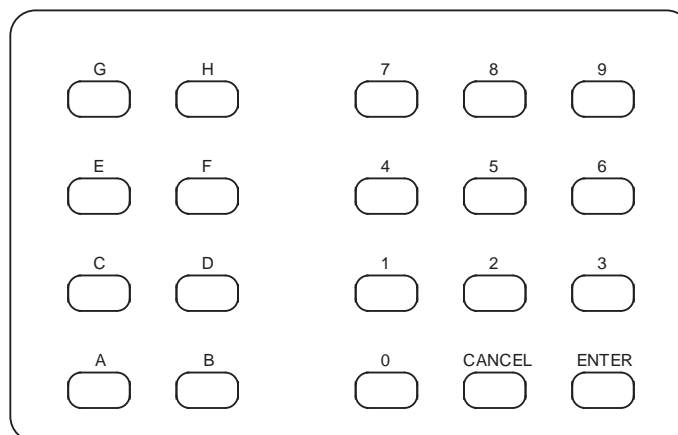
When the RELAYS indicator is lit, a setup can also be sent to the relays and displayed by entering a valid location and pressing ENTER, or by pressing a SCROLL key to send and display the setup at RELAY STEP ±1. If you press and hold a SCROLL key, the RELAY STEP field is updated continuously. As the SCROLL keys increment and decrement the RELAY STEP field through location 000, there is no effect on the relays. That is, when the RELAY STEP is decremented from 001 to 000, or when incremented from 100 to 000, the relays do not change state.

If the relays change due to a trigger or IEEE-488 commands, the crosspoint display changes only if the RELAYS indicator is lit.

## 4.6 Modifying crosspoint display

After choosing the source of the setup, a crosspoint display can be modified by turning on/off crosspoint LEDs with front panel keys or the light pen. As discussed in the next paragraph, if the AUTOMATIC (COPY DISPLAY→RELAYS) indicator is lit, these actions open/close relays immediately.

The alphabetic data entry keys (A-H) are for entering the row part of a crosspoint address. The numeric keys (0-9) are for entering column numbers. Use the CANCEL key to remove incorrect entries from the alphanumeric display. Refer to Figure 4-6.



**Figure 4-6**  
Data entry keys

The maximum valid column number with a single unit is 72. If several mainframes are connected and programmed for master/slave operation, the maximum column can be up to 360 (with five units).

When a valid crosspoint address (row and column) is in the alphanumeric display, pressing the OPEN key turns off the crosspoint display LED. (The message INVALID INPUT is displayed for addresses out of range.) If the AUTOMATIC (COPY DISPLAY → RELAYS) indicator is lit, the corresponding relay opens immediately. The CLOSE key performs the same action as the OPEN key except that it turns on crosspoint display LEDs and relays.

Pressing the CLEAR key turns off all crosspoint display LEDs. If the AUTOMATIC (COPY DISPLAY → RELAYS) indicator is lit, all relays are opened immediately.

The CROSSPOINT DISPLAY MODIFIED indicator lights and the MEMORY or RELAYS indicator go out when changes are made to the crosspoint display, making it different from the configuration of its source. It also lights when opening an already open crosspoint and closing an already closed crosspoint. The SCROLL keys are not active when the CROSSPOINT DISPLAY MODIFIED indicator is lit.

The optional light pen can also be used to turn on and off crosspoint LEDs. Just hold it perpendicular to the front panel overlay at the desired LED and press the button on its barrel. This action toggles the state of the LED.

The maximum number of simultaneously closed crosspoints depends on the specified drive current per crosspoint of each card. The total relay drive current required per mainframe cannot exceed 48.5A, since the 6V/50A power supply also provides 1.5A for the front panel display.

## 4.7 Copying crosspoint display

The setup data displayed on the crosspoint LEDs can be stored in non-volatile memory of the Model 707A or can be sent directly to the relays by pressing either the COPY DISPLAY → MEMORY or the COPY DISPLAY → RELAYS key, seen previously in Figure 4-5.

With the COPY DISPLAY → MEMORY key, the displayed crosspoint configuration is stored at the setup location shown in MEMORY STEP field. It overwrites the present setup data at that location. If a valid location is keyed in first, pressing this key stores the crosspoint configuration at that setup and sets the MEMORY STEP field to that location. If the CROSSPOINT DISPLAY MODIFIED indicator is lit, it goes out and the MEMORY LED lights. The INVALID INPUT message is displayed briefly if you try to copy to a setup location below one or above 100.

In master/slave configurations, each unit stores its own portion of each stored setup.

When the COPY DISPLAY → RELAYS key is pressed, the displayed crosspoint configuration is sent to the relays:

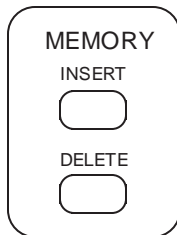
- If the MEMORY indicator is lit (i.e., the crosspoint display shows an unmodified setup from memory), the RELAY STEP field is set to the MEMORY STEP field. In effect, this copies a setup from memory to the relays.
- If the RELAYS indicator is lit, the RELAY STEP field is not affected, as it reflects the last stored setup sent to the relays.
- If CROSSPOINT DISPLAY MODIFIED is lit, it goes out and the RELAYS LED lights.



Copying the crosspoint display to the relays can be performed automatically with the toggle-action AUTOMATIC (COPY DISPLAY → RELAYS) key. When the AUTOMATIC indicator is lit, any change to the crosspoint display is also sent to the relays at the same time. This action is apparent when scrolling through unmodified stored setups, as the MEMORY STEP and RELAY STEP fields will sequence together. Changes to the crosspoint display while the AUTOMATIC LED and RELAY LEDs are lit cause the CROSSPOINT DISPLAY MODIFIED LED to blink and the RELAYS LED to remain lit.

### 4.8 Inserting and deleting stored setups

The two keys in the MEMORY group (see Figure 4-7) operate on setups stored in Model 707A memory. These keys are active only when the MEMORY LED is lit.



**Figure 4-7**  
Memory keys

Use the INSERT key to place a blank setup at the memory location shown in the MEMORY STEP field. While the insert is taking place, the alphanumeric display is blank. All setups from the selected setup through 99 are moved up one location. (Setup 100 is deleted by overwriting it with setup 99.) After the insert operation, the crosspoint LEDs display a blank setup.

If a valid location is keyed in first, the MEMORY STEP field is set there and then the insert operation takes place.

Pressing the DELETE key removes the stored setup at the location shown in the MEMORY STEP field. While the delete is taking place, the alphanumeric display is blank. All setups higher than the selected setup are moved down one location. (Setup 100 is cleared.) After the delete operation, the crosspoint LEDs display the new setup “nnn”, which previously was setup “nnn+1”.

If a valid location is keyed in first, the MEMORY STEP field is set there and then the deletion takes place.

In master/slave configurations, the insert blank setup and delete stored setup operations perform similarly, except on all units of the system.

### 4.9 Menu operations

The Model 707A has several operations that are performed by front panel menu items. Select the first item by pressing the MENU key, subsequent presses of MENU display the remaining items (see Table 4-5). To view all current menu selections just press and hold the MENU key.

Status items are displayed with no user action. Numeric items are modified by keying in the desired value with the data entry keys and pressing ENTER. Multiple choice items are selected by scrolling through the choices until the desired one is displayed, then pressing ENTER. Immediate action items are invoked by pressing ENTER.

If no modifications are made with the SCROLL or data entry keys, pressing CANCEL exits from the menu without changing any values; otherwise CANCEL restores the current value of the parameter. Pressing ENTER exits from the menu (with changes), except when programming the digital output status.

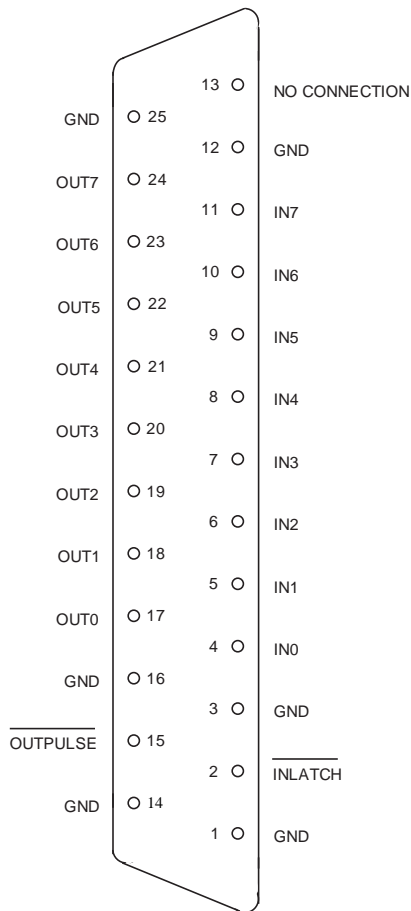
**Table 4-5**  
Menu operations

<b>Message</b>	<b>Item Description</b>	<b>Type</b>
IN iii OUT 000	View digital input, program digital output.	status/numeric
EXT TRIG FALL EXT TRIG RISE	Select which edge of external trigger pulse triggers Model 707A (falling or rising).	multiple choice
MATRIX RDY LO MATRIX RDY HI	Select matrix ready output level (active LO or HI).	multiple choice
STANDALONE MASTER	Select stand-alone or master/slave operation.	multiple choice
IEEE-488 nn	Program IEEE-488 bus address.	numeric
HWSETL nnn mS	View longest relay (hardware) settling time of cards in system.	status
n cccc	View slot number (n) and card label (cccc).	status
SELF TEST	Execute self test.	immediate action
FACTORY INIT	Return to factory defaults. (All stored setups are cleared.)	immediate action

### 4.9.1 Digital I/O

The TTL-compatible DIGITAL I/O port has eight data lines for inputs, eight data lines for outputs, and two control lines for handshaking. The pinout for the rear panel DB-25 connector is shown in Figure 4-8. Status of the input lines is viewed and states of the output lines are programmed through the first menu item. With no input connections and power-up default conditions for the output, the alphanumeric display will read the following decimal values:

IN 255 OUT 000



**Figure 4-8**  
Digital I/O port

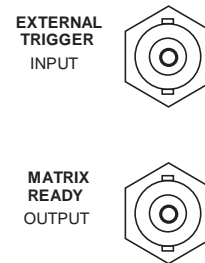
The digital inputs are logic high with no connections. Use the control line INLATCH (low true) to latch in the digital inputs when changing an input state.

To program the digital output states, select the desired decimal value with the data entry keys and press ENTER. You can now key in another value and press ENTER, or press CANCEL to exit menu mode, or press MENU to continue to the next item. Each time the digital outputs are programmed, even if the states are not changed, the control line OUT-PULSE is brought low.

With master/slave configurations, only the DIGITAL I/O port of the master unit is available for viewing and programming.

### 4.9.2 External trigger

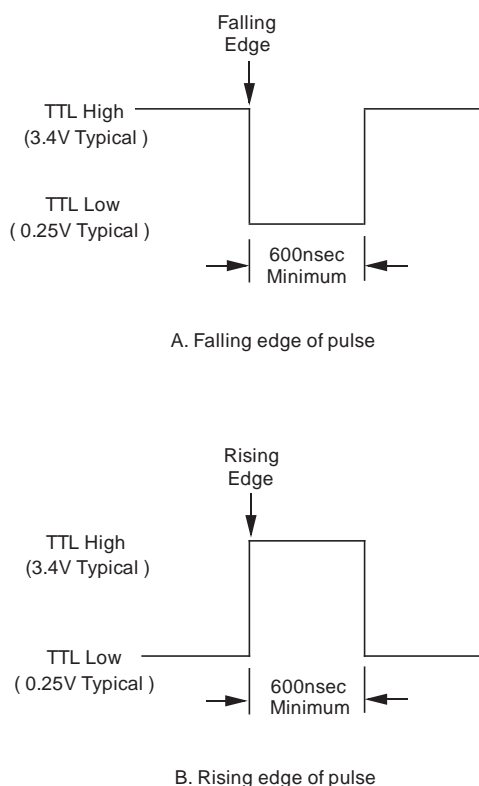
If triggers are enabled, and external trigger is selected as a source, a TTL-compatible pulse of at least 600nsec duration at the rear panel EXTERNAL TRIGGER INPUT jack triggers the Model 707A. The input BNC jack is shown in Figure 4-9.



**Figure 4-9**  
Rear panel BNC jacks

The unit can be programmed with a menu item for which edge (falling or rising) of the external trigger pulse causes a transfer of stored setup data to the relays. Sample trigger pulses are shown in Figure 4-10. To select which pulse edge triggers, use the MENU key to choose the menu item for external trigger. The power-up default display will read:

EXT TRIG FALL



**Figure 4-10**  
Sample external trigger pulses

To choose the alternate external trigger state, use the SCROLL ▲ or ▼ keys, then press ENTER. This action also exits from the menu mode. (Pressing CANCEL instead of ENTER returns external trigger to its previous state and the Model 707A remains in menu mode.)

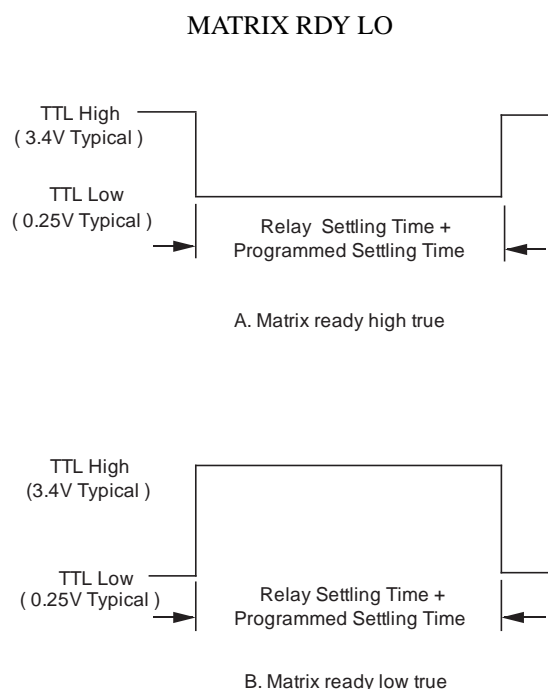
In master/slave configurations, only the EXTERNAL TRIGGER INPUT port of the master unit is active.

See paragraph 4.11 for more information on triggering the Model 707A.

### 4.9.3 Matrix ready

The Model 707A provides a TTL-compatible signal at its rear panel MATRIX READY OUTPUT jack. The output BNC jack was shown in Figure 4-9. The MATRIX READY signal goes false when relays are switched and goes true at the end of the programmed settling time. (As described in paragraph 4.11, this is also after the relay settling time.)

Through a menu item, the unit can be programmed for a high- or low-true MATRIX READY signal, as seen in Figure 4-11. To select the active state of the signal, press the MENU key until the MATRIX RDY item is displayed. The power-up default display will read:



**Figure 4-11**  
Sample matrix ready pulses

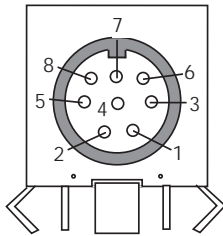
To choose the other active state, use the SCROLL ▲ or ▼ keys, then press ENTER. This action also exits from the menu mode. (Pressing CANCEL instead of ENTER returns matrix ready to its previous state and the Model 707A remains in menu mode.)

In master/slave configurations, the MATRIX READY signals of all units function, but only that of the master is to be considered accurate.

### 4.9.4 Stand-alone and master/slave

One method to expand system size is to connect up to five mainframes in a master/slave configuration, where all units are daisy-chained for serial communication and control. System operations are performed through the master unit, either over the IEEE-488 bus or the master's front panel (including the light pen). A master/slave system appears as a single unit (and IEEE-488 address) with a maximum size of 8 rows by 360 columns. Selection of stand-alone or master/slave operation is done with a menu item.

As previously described in paragraph 3.5, the MASTER/SLAVE OUT and MASTER/SLAVE IN rear panel connectors are used to connect DIN cables in a closed loop. The connector pinouts are defined in Figure 4-12.



Pin	Master/Slave IN	Master/Slave Out
1	M/S TRIGGER (low true)	M/S TRIGGER (low true)
2	ALLREADY	ALLREADY
3	LRESET (low true)	LRESET (low true)
4	LPSENSE (low true)	LPSENSE (low true)
5	RxDATA	TxDATA
6-8	Chassis Ground	Chassis Ground

**Figure 4-12**  
Master/slave connectors

After interconnecting and powering up all units, one unit is selected to be a master.

This action is performed by pressing the MENU key of the desired master mainframe until the display reads STAND ALONE. Next, scroll up or down to the MASTER message. Then, press the ENTER key to initiate the master/slave loop. If the loop is complete (MASTER/SLAVE OUT to MASTER/SLAVE IN in a daisy chain among all units), the master unit will exit menu mode and the other units will display SLAVE 1, SLAVE 2, etc. (The slave number is determined by the unit's position in the loop.) If the loop of DIN cables is not closed, the master will display the message M/S ERROR and all units will remain as stand-alones.

When the units are powered up one at a time, they will display the message M/S LOOP DOWN until all units are powered.

#### CAUTION

**When it is necessary to cycle power on a slave unit, turn off all units in the master/slave configuration. This procedure prevents the open communication and control loop from putting the slave unit in an undesirable state.**

During master/slave operation, most front and rear panel controls of the slave units are inactive. Table 4-6 shows which controls and indicators remain active for slave units.

The master unit communicates with the slaves only when necessary; it does not continuously monitor the status of the closed-loop configuration. Hence, a disconnected master/slave loop cable is not detected, and the message M/S ERROR is not displayed, until the master attempts to send or receive data around the loop. The steps taken by a master unit to recover from an M/S ERROR are outlined below:

1. The master stops processing IEEE-488 bus commands, returns to stand-alone operation, and disables.
2. The slave units remain the same as before the error occurred.
3. To re-initialize the loop, ensure that master/slave cables are secure, and select master/slave operations from the mainframe that previously was master.

**Table 4-1**  
Status of slave unit controls

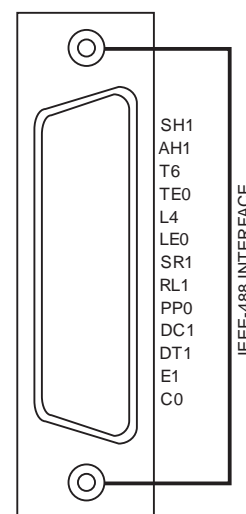
Control, indicator, or connector	Status
POWER	active
CROSSPOINT DISPLAY Group:	
MEMORY key and LED	only LED active
RELAYS key and LED	only LED active
CROSSPOINT DISPLAY	active
MODIFIED LED	
COPY DISPLAY — MEMORY	inactive
COPY DISPLAY — RELAYS	inactive
AUTOMATIC key and LED	only LED active
SCROLL ▲ and SCROLL ▼	inactive
MEMORY Group:	
INSERT	inactive
DELETE	inactive
MENU key and LED	inactive
SWITCHING Group:	
SETTLING TIME	inactive
MAKE/BREAK	inactive
BREAK/MAKE	inactive
LOCAL	
TRIGGER Group:	
ENABLE key and LED	only LED active
SOURCE	inactive
MANUAL	inactive
Data Entry (A-H, 0-9)	inactive
CANCEL, ENTER	inactive
RESET	inactive
CLEAR, OPEN, CLOSE	inactive
Alphanumeric Display	active (Note 1)
TALK, LISTEN, REMOTE LEDs	inactive
Crosspoint Display LEDs	active
MAKE/BREAK and BREAK/MAKE	active
Row LEDs	
LIGHT PEN	inactive
Rear Panel Connectors:	
MASTER/SLAVE IN	active
MASTER/SLAVE OUT	active
EXTERNAL TRIGGER INPUT	inactive
MATRIX READY OUTPUT	active (Note 2)
REALY TEST	not used
DIGITAL I/O	inactive (Note 3)
IEEE-488 INTERFACE	not used

Notes:

1. Messages only.
2. Timing accuracy not guaranteed.
3. Outputs set to all low.

### 4.9.5 IEEE-488 bus address

The Model 707A communicates over the IEEE-488 bus through the rear panel connection shown in Figure 4-13. When connected to a bus controller, instrument operating modes can be programmed. Note that IEEE-488 common is always grounded. IEEE-488 interface function codes are marked adjacent to the connector.



**Figure 4-13**  
IEEE-488 bus connector

A menu item is used to set the primary address of the Model 707A for bus operation. The primary address of the Model 707A is factory set to 18, but it may be set to any value between 0 and 30 as long as address conflicts with other instruments or the bus controller are avoided.

To check the present primary address or to change to a new one, perform the following procedure:

1. Press the MENU key until the current primary address is displayed. For example, if the instrument is set to primary address 18, the following message is displayed:  
IEEE-488 18
2. Press CANCEL to retain the present address and exit menu mode.
3. To change the primary address, use the data entry keys to key in a new value, then press ENTER. This action will also exit menu mode. The new address will be stored in memory so that the instrument powers up to that address.

#### NOTE

Each device on the bus must have a unique primary address. Failure to observe this precaution will probably result in erratic bus operation.

Section 5 contains detailed information on operating the Model 707A over the IEEE-488.

#### 4.9.6 Relay (hardware) settling times

The card specification “relay settling time” is the time needed for the relays to actuate or release (including contact bounce time) and pass a clean signal. Since this specification is card dependent, the Model 707A must identify on power-up which cards are installed to determine the longest relay settling time in the system (stand-alone or master/slave). This value is not user-modified, but the total settling time for a switching operation can be lengthened by using the programmed settling time, as explained in paragraph 4.10.

To view the relay (hardware) settling time of the system, press the MENU key until the display reads:

HWSETL 015 mS

In this example, there is a Model 7072 or 7073 matrix card present in the system. Press CANCEL to exit the menu mode.

See paragraph 4.11 for a discussion of settling times and triggers.

#### 4.9.7 Card labels

Each matrix card can be identified by the Model 707A. You can view the card labels of the present configuration by using a menu item. Press the MENU key until the alphanumeric display reads:

1 7072

In this case, a Model 7072 is in slot #1. Use the SCROLL to view the card label of the next slot. If no card is present, the display will be:

2 NONE

Continue pressing the SCROLL ▲ or ▼ keys for the remaining slots or press CANCEL to exit the menu mode.

In master/slave configurations, all units display card labels simultaneously.

#### 4.9.8 Self-test

The self-test program is intended to check ROM, RAM, and the front panel LED indicators. This test is also part of the power-up sequence. If you want to run the test without cycling power, use the following procedure to select and run it:

1. Press the menu key until the display reads SELF TEST.
2. Press the ENTER key to initiate the test. The unit's ROM and RAM are checked. Next, all the front panel LEDs are lit for your inspection. If no errors are detected, menu mode is exited.

If there is an error in ROM or RAM, a ROM FAIL or RAM FAIL message is displayed until a key press or bus operation. See Section 7 for troubleshooting procedures.

For master/slave configurations, all units are tested simultaneously, so you might have to run the test more than once to inspect all LED indicators.

#### 4.9.9 Factory defaults

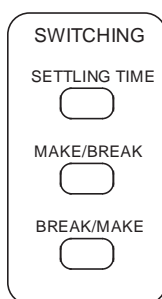
A menu item can be used to return the Model 707A to the factory default conditions previously listed in Table 4-2. To initiate this action, follow these steps:

1. Press the MENU key until the display shows FACTORY INIT.
2. Press the ENTER key. The display will read ENTER IF SURE. (This additional keypress is to prevent unintentional initialization.) At this step you can press CANCEL to exit menu mode, or you can continue with the next step.
3. Press the ENTER key again. The Model 707A will return to factory settings and exit menu mode.

In master/slave configurations, all units return to factory defaults when this menu item is selected from the master unit.

## 4.10 Selecting switching parameters

The Model 707A has three switching parameters that are user-modified: the programmed settling time, make-before-break rows, and break-before-make rows. These values of these parameters are in effect for all relay switching until they are changed. Figure 4-14 shows the front panel keys of the switching group.



**Figure 4-14**  
Switching keys

### 4.10.1 Programmed settling time

The programmed settling time is a variable switching delay that can be used to lengthen the fixed delay of the relay (hardware) settling time. You can select, in 1msec increments, up to 65 seconds of an additional switching delay.

If an additional trigger is received during this time, it is processed and the message NOT SETTLED is displayed. At the end of the programmed settling time, the Model 707A sets the MATRIX READY output true.

To view or change the programmed settling time, press the SETTling TIME key in the SWITCHING key group. The value of the programmed settling time value is displayed as:

```
SETL 00000 mS
```

To exit the display without changing the value, just press CANCEL. To change the value, enter between 0-65000 with the data entry keys and press ENTER. This action also returns the display to the RELAY STEP and MEMORY STEP.

The programmed settling time is in effect for all crosspoint relay open/close operations until it is reprogrammed. Its effect on trigger response times is described in paragraph 4.11.

### 4.10.2 Make/break and break/make rows

Make-before-break switching of relays is defined as connecting a new circuit before disconnecting the present circuit. It is used to eliminate transients caused by switching between current sources. Break-before-make switching means to disconnect the present circuit before connecting a new circuit. It is used to avoid momentary shorting of two voltage sources. Both of these switching operators are supported by the Model 707A.

Rows of crosspoint relays are user-selectable for make/break (make-before-break), break/make (break-before-make), or “don't care” operation. The selections will be in effect for all switching until new choices are made. When make/break or break/make operation is chosen, the Model 707A automatically switches the crosspoint relays through intermediate set-ups to perform the following steps:

1. Crosspoints in break/make rows are opened.
2. Crosspoints in make/break rows are closed.
3. Crosspoints in make/break rows are opened.
4. Crosspoints in break/make rows are closed; crosspoints in “don't care” rows are opened or closed accordingly.

These steps are transparent to the user except for the increased settling time. If either make/break or break/make rows are not selected, the appropriate steps in the previous list are deleted and the total settling time decreases. As make/break and break/make operations affect settling times and trigger response, these operations are further discussed in paragraph 4.11.

The front panel MAKE/BREAK and BREAK/MAKE keys are used in conjunction with the data entry keys to select rows for operation as make/break or break/make. When a row designation (A-H) is selected and displayed by itself, the MAKE/BREAK and BREAK/MAKE keys toggle the state of the MAKE/BREAK or BREAK/MAKE LED for that row and immediately reprograms the Model 707A for the new operation. The INVALID INPUT message is displayed briefly if you press the MAKE/BREAK or BREAK/MAKE key without first selecting a row or if a row/column address is displayed instead of just a row.

Note that selecting a row for make/break de-selects it for break/make and vice versa. The various front panel operations are listed in Table 4-7.



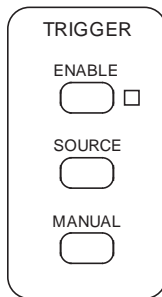
**Table 4-7**  
Make/break and break/make front panel operation

Present State	Action	Next State
Don't Care	Select Make/Break Select Break/Make	Make/Break Break/Make
Make/Break	Select Break/Make De-select Make/Break	Break/Make Don't Care
Break/Make	Select Make/Break De-select Break/Make	Make/Break Don't Care

The optional light pen can be used to toggle the LED states directly. The light pen can also select rows for make/break or break/make operation from slave units. The row selection is in effect for all units connected in a master/slave configuration.

## 4.11 Triggering

When a Model 707A stand-alone or master unit is triggered, the stored relay setup from RELAY STEP+1 is sent to the relays. Triggers are enabled with the front panel ENABLE key of the TRIGGER group (see Figure 4-15). This key toggles between triggers enabled and triggers disabled. When triggers are enabled, the ENABLE LED is lit.



**Figure 4-15**  
Trigger keys

The maximum trigger rate is specified with no make/break or break/make rows selected. As will be described in paragraph 4.11.3, additional switching delays are necessary with make/break or break/make operation.

### 4.11.1 Trigger sources

The programmed trigger source provides the stimulus to increment to the next stored setup. Trigger sources include:

- Front panel MANUAL key — When triggers are enabled, this key is always operational (on stand-alone and master units) regardless of the selected source (unless the unit is placed in remote over the IEEE-488 bus).
- External trigger pulse — An appropriate pulse, applied to the EXTERNAL TRIGGER INPUT jack on the rear panel, provides the trigger stimulus.
- IEEE command triggers — IEEE-488 GET, X, or talk commands provide the stimulus when the appropriate source is selected.

Select the trigger source as follows:

1. Press SOURCE and note that the current trigger source is displayed:

TRIG ON EXT

This is the display for external triggering (the power-up default). Table 4-8 lists the displays for all trigger sources.

2. Press the SCROLL or keys until the desired trigger source is displayed. Then press ENTER to select it and exit menu mode.
3. If another source is scrolled to before pressing ENTER, pressing CANCEL once returns the old selection, pressing it again exits menu mode.

**Table 4-8**  
Front panel messages for trigger sources

Message	Description 1
TRIG ON TALK	IEEE talk command
TRIG ON GET	IEEE GET command
TRIG ON X	IEEE X command
TRIG ON EXT	External trigger pulse
TRIG ON KEY	Front panel MANUAL key only*

\*If triggers are enabled, pressing MANUAL emulates the selected trigger source.

### 4.11.2 Front panel triggering

To trigger the Model 707A from the front panel, simply press the MANUAL key. (Press and hold for auto-repeat.) If triggers are enabled, this key is always operational regardless of the selected trigger source (unless the unit is placed in remote over the IEEE-488 bus, in which case all front panel keys except LOCAL are locked out). Thus, front panel trigger source selection (TRIG ON KEY) provides a means to lock out all other trigger sources when only front panel triggering is desired.

Triggering will stop when the RELAY STEP field increments to 100. If you press MANUAL and the unit is not ready, an error message will be displayed, as discussed in the following paragraph.

### 4.11.3 Trigger overrun conditions

Once the instrument is triggered, it begins transferring relay setup data from mainframe memory to the matrix cards. If a second trigger is received while the unit is still transferring data, a trigger overrun condition will occur. In this case, the second trigger is not processed and the unit will display the following error message:

TRIG OVERRUN

After the time required for transferring relay data has elapsed, the Model 707A is able to process another trigger. If a trigger is received before the programmed settling time has elapsed, the following message is displayed:

NOT SETTLED

Figure 4-16 shows an example setup change and a timing diagram of the READY (for trigger) pulse and a high true MATRIX READY pulse when the Model 707A is processing the trigger. (The status of these signals is available in the serial poll byte, see Section 5.) This timing is for setups with no make/break or break/make rows.

When either make/break or break/make operation is selected, but not both, the Model 707A switches through an intermediate setup to ensure proper relay operation. If only make/break rows are selected, the Model 707A takes these steps:

1. Closes crosspoints in make/break rows yielding an intermediate setup.
2. Opens crosspoints in make/break rows and opens/closes crosspoints in “don't care” rows yielding the desired setup.

If only break/make rows are selected, the Model 707A takes these steps:

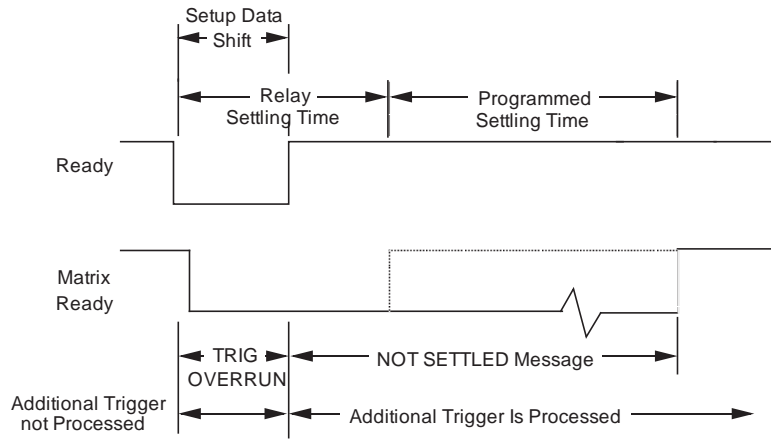
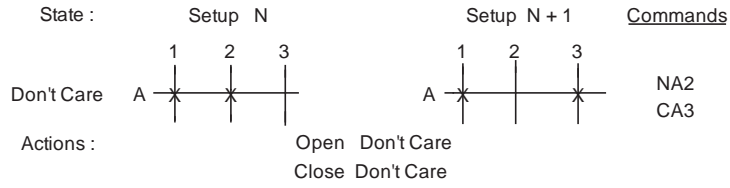
1. Opens crosspoints in break/make rows yielding an intermediate setup.
2. Closes crosspoints in break/make rows and opens/closes crosspoints in “don't care” rows yielding the desired setup.

An example of these operations is shown in Figure 4-17 with its corresponding timing diagram. By comparing Figures 4-16 and 4-17, you can see that the intermediate setup needed for make/break or break/make causes a delay in the assertion of READY and MATRIX READY equal to the relay settling time.

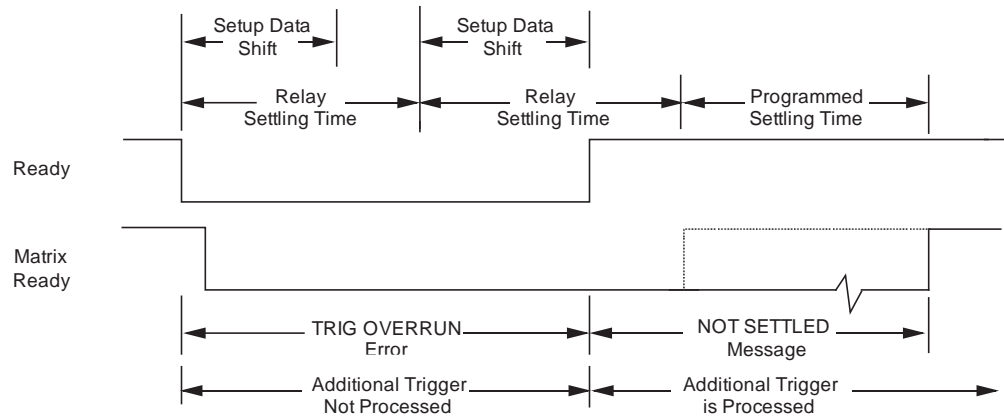
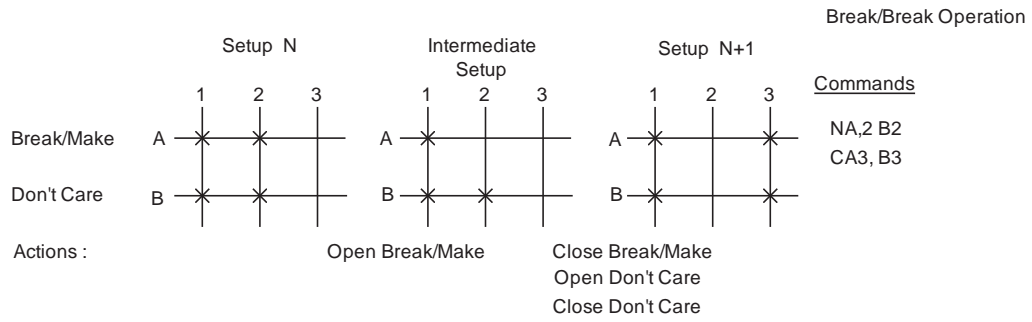
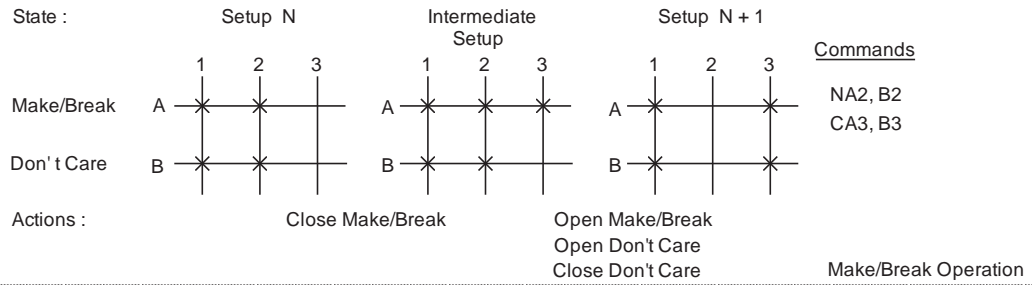
When a combination of make/break and break/make rows are selected, the Model 707A must switch through three intermediate setups to ensure proper relay operation. The steps taken by the unit are as follows:

1. Opens crosspoints in break/make rows yielding the first intermediate setup.
2. Closes crosspoints in make/break rows yielding the second intermediate setup.
3. Opens crosspoints in make/break rows yielding the third intermediate setup.
4. Closes crosspoints in break/make rows and opens/closes crosspoints in “don't care” rows yielding the desired setup.

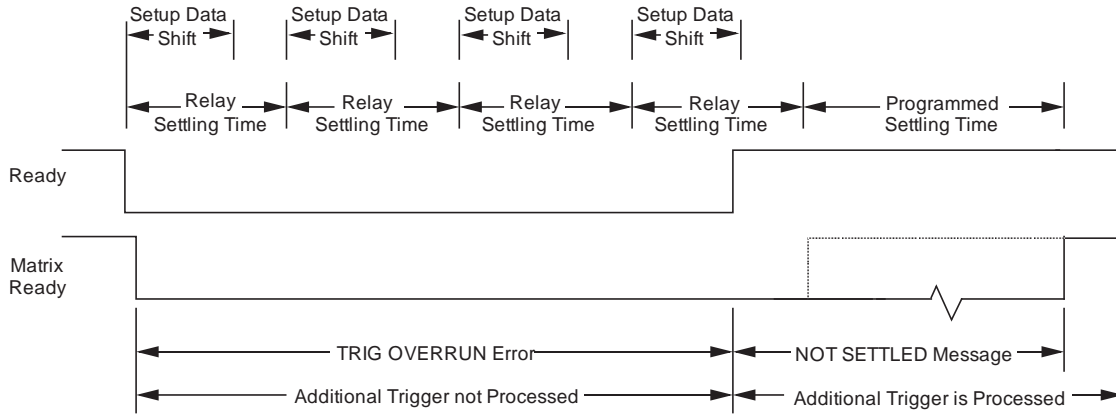
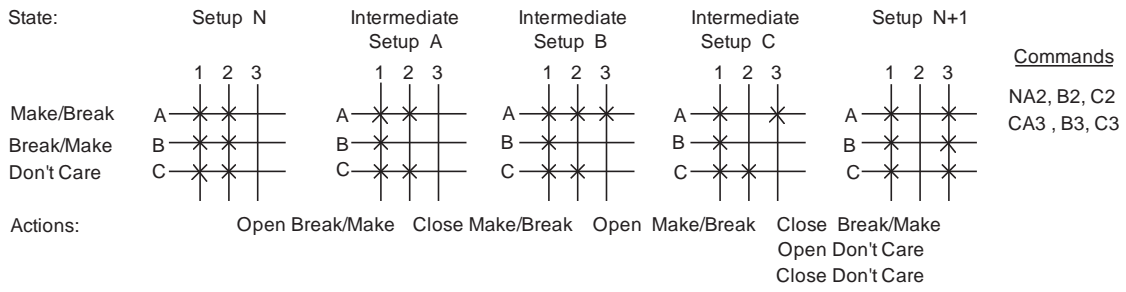
Figure 4-18 shows an example setup change with the necessary intermediate setups. As the timing diagram shows, three additional relay settling time intervals are needed for the intermediate setups.



**Figure 4-16**  
Timing without make/break or break/make rows



**Figure 4-17**  
Timing with either make/break or break/make rows



**Figure 4-18**  
Timing with both make/break and break/make rows

#### 4.11.4 External trigger input

To use external triggering, first select that source with the MENU and SCROLL keys as described in paragraph 4.11.1. With triggers enabled, the unit will then be triggered when an input pulse with the specifications previously shown in Figure 4-10 is applied to the EXTERNAL TRIGGER INPUT jack. The unit is triggered on either the falling (leading) or rising (trailing) edge of the pulse, as selected by a menu item.

#### 4.11.5 Matrix ready output

The matrix ready output provides a TTL-compatible signal, as shown previously in Figure 4-11. This signal can be used to inform other instruments when the total settling time is complete. It is programmable by a menu item for high or low true. The leading edge of the “true” level indicates the end of the total settling time (relay settling time plus programmed settling time).

#### 4.11.6 IEEE-488 bus triggering

To trigger a setup change with an IEEE-488 trigger source, you must send the appropriate IEEE-488 command over the bus: X, talk, or GET depending on the selected source. Trigger on GET allows the fastest IEEE-488 triggering response. See Section 5 for details on bus triggering.

If one of these commands has been selected as the trigger source, you can also trigger the unit by pressing the MANUAL key unless the unit is in remote.

### 4.12 Resetting

The reset operation performs the same functions as cycling power except power-up self-checking. If a master/slave error is detected during reset, the unit will revert to stand-alone operation. The front panel RESET key is used to initiate a reset operation.

Reset, power-up, and factory default conditions were previously listed in Table 4-2.

# 5

## IEEE-488 Programming

---

### 5.1 Introduction

This section contains information on programming the Model 707A over the IEEE-488 bus. Detailed instructions for all programmable functions are included. However, information concerning operating modes presented elsewhere are not repeated.

### 5.2 IEEE-488 quick start

The following paragraphs provide a step-by-step procedure for putting a Model 707A on the bus to program some basic commands.

#### **Step 1: Connect the Model 707A to the controller**

With power off, connect the Model 707A to the IEEE-488 interface of the controller using a standard interface cable. Some controllers include an integral cable; others require a separate cable. Paragraph 5.3 discusses bus connections in detail.

#### **Step 2: Select the primary address**

The primary address is a way for the controller to refer to each device on the bus individually. Consequently, the primary address of your Model 707A must be the same as the primary address specified in the controller's programming language, or you cannot program the instrument. Each device on the bus must have a different primary address.

The primary address of your Model 707A is set to 18 at the factory, but you can set the address to values between 0 and 30 for a stand-alone unit, or 31 and 60 for a master in a master/slave loop (refer to paragraph 5.5).

#### **Step 3: Write your program**

All operations require a simple program to send commands to the instrument. Figure 5-1 shows a flowchart of a program to select make/break and break/make rows, modify cross-points of a setup stored in memory, send the setup to the relays, and then request data of the present relay setup.

The corresponding program (written in MS QBASIC supplied with MS-DOS 5.0 and later) is contained in three parts for this example. The program assumes a primary IEEE-488 address of 18 for the Model 707A and that power-up default conditions exist in the unit.

**Sample Program**

```

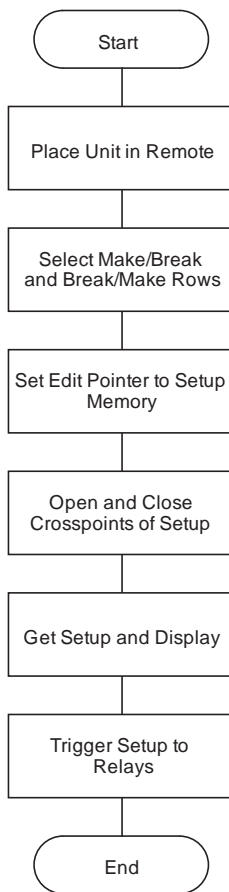
DIM A$[200],C$[200]
PRINT #1, "REMOTE 18"

PRINT #1, "OUTPUT 18;V11000000W00000011X"

PRINT #1, "OUTPUT 18;E1Z1,0X"
COMMAND:
LINE INPUT "CROSSPOINTS COMMAND", C$
IF LEN (C$)=0 THEN STOP
PRINT #1, "OUTPUT 18;C$+"X"
GOTO COMMAND
END
    
```

**Comments**

- ' Dimension crosspoint input and display.
- ' Tell Model 707A (at IEEE-488 location 18) to listen over bus.
- ' Select rows A and B for make/break and rows G and H for break/make.
- ' Set edit pointer to setup #1, and send setup #1 to relays and display.
- ' Allow user to input crosspoint data.
- ' Check for null string.
- ' Send command string to Model 707A.
- ' Allow user to input additional crosspoint data.



**Figure 5-1**  
Flowchart of example program

**Step 4: Open and close crosspoints**

You can open, close, and clear crosspoints by sending the appropriate command, which is made up of an ASCII letter representing the command, followed by one or more characters for the command options. Commands can be grouped together in one string. The command strings are not opening and closing relays unless the edit pointer is set to zero.

To open and close crosspoints over the bus, run the previous program and enter a command string when prompted. Some example strings are shown in Table 5-1.

Terminate each string by pressing RETURN on the controller keyboard. If a null string is entered, the program ends.

**Table 5-1**  
Sample strings

Sample string	Description
"P1"	Clear (open) all crosspoints of setup #1.
"CA5 , A6 , B9 , B10 "	Set (close) crosspoints A5, A6, B9, B10.
"NA5 , A6 "	Clear (open) crosspoints A5, A6.
"CA1 , A2NB9 , B10 "	Set (close) A1, A2 and clear (open) B9, B10.



### Step 5: Modify program for requesting data

To display or print setup data, you must specify one of the data output formats that sends ASCII characters. Note that a variety of data formats are available, as discussed in paragraph 5.9. The data can be a setup stored in memory or the present relay setup. Modify the previous sample program with the following statements. Add the statements immediately before the GOTO line.

```
PRINT #1, "OUTPUT 18;  ' Set data format for setup #1.
U2,1G2X"
PRINT #1, "ENTER 18"    ' Get stored setup data
LINE INPUT #2, A$      ' and print.
PRINT A$
```

When the program is run with these statements, it lists the closed crosspoints that you have entered.

### Step 6: Modify program for triggering

Triggers provide a quick way for copying relay data from a pre-programmed setup to the relays. Each valid trigger causes the next sequential setup to be copied to the relays and the relay pointer to be updated.

Modify the previous sample program with the following statements. Add the statements immediately before the END line.

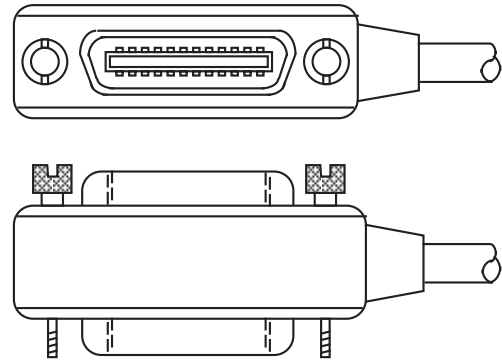
```
PRINT "PRESS ANY KEY TO  ' Wait for keypress.
CONTINUE"
DO
LOOP WHILE INKEY$=" "    ' Enable triggers, select
PRINT #1, "OUTPUT      ' trigger-on GET.
18;F1T2X"
PRINT #1, "TRIGGER 18"  ' Trigger setup #1 to
                        ' relays.
```

When any key on the keyboard is pressed, this program modification triggers setup #1 to the relays. This is because the relay step pointer, which is different from the edit pointer, was set to zero by power-up.

## 5.3 Bus cable connections

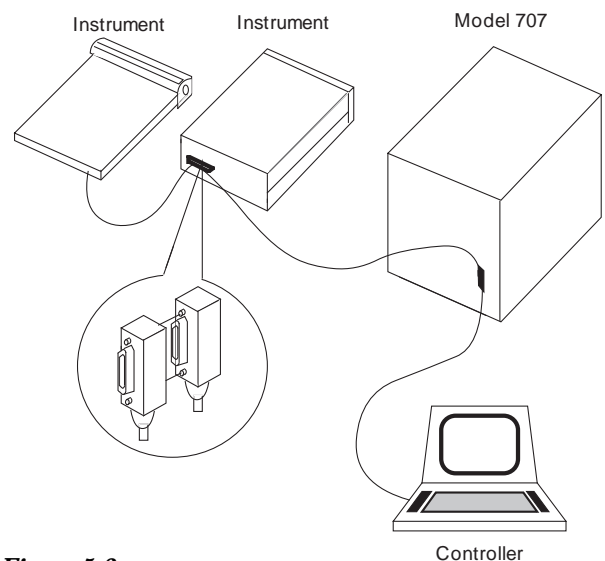
The following paragraphs provide information needed to connect instrumentation to the IEEE-488 bus. The Model 707A is connected to the IEEE-488 bus through a cable equipped with standard IEEE-488 connectors. See Figure

5-2. Two screws are located on each connector to ensure that connections remain secure. Present standards call for metric threads, as identified by dark colored screws. (Earlier versions had silver colored screws. Do not use these connectors with the Model 707A.)



**Figure 5-2**  
IEEE-488 connector

A typical connecting scheme is shown in Figure 5-3. Each cable normally has a standard connector on each end. These connectors are designed to be stacked to allow a number of parallel connections on one instrument. To avoid possible damage, do not stack more than three connectors on any one instrument.



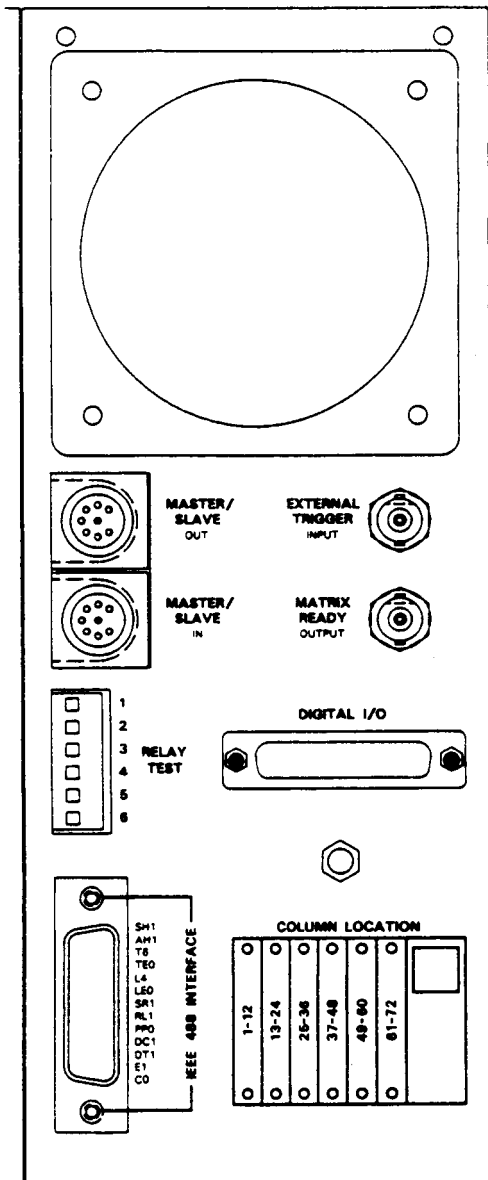
**Figure 5-3**  
IEEE-488 connections

**NOTE**

To minimize interference caused by electromagnetic radiation, use only shielded IEEE-488 cables. The Model 7007-1 and 7007-2 shielded IEEE-488 cables are available from Keithley Instruments.

Connect the cable to the Model 707A as follows:

1. Line up the connector on the cable with the connector on the rear panel of the instrument. Figure 5-4 shows the IEEE-488 connector location.



**Figure 5-4**  
IEEE-488 connector location

2. Tighten screws securely, but do not overtighten them. (Overtightening can break the connector.)
3. Add additional connectors from other instruments, as required.
4. Make sure the other end of the cable is properly connected to the controller. Some controllers have an IEEE-488 type connector, while others do not. Consult the instruction manual of your controller for the proper connecting method.

**NOTE**

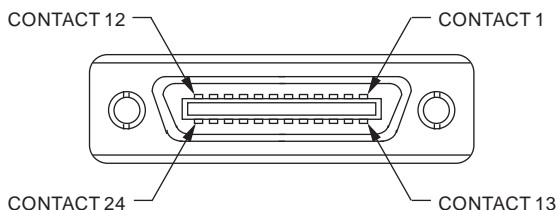
The IEEE-488 bus is limited to a maximum of 15 devices, including the controller. Also, the maximum cable length is limited to 20 meters, or 2 meters multiplied by the number of devices, whichever is less. Failure to observe these limits may result in erratic bus operation.

In master/slave configurations, only the master unit is connected to the IEEE-488 bus. If slave units are also connected, erratic bus operation results. Custom cables may be constructed by using the contact assignments listed in Table 5-2 and shown in Figure 5-5.

**Table 5-2**  
Contact assignments

Number	Contact designation	IEEE-488 type
1	DIO1	Data
2	DIO2	Data
3	DIO3	Data
4	DIO4	Data
5	EOI (24)*	Management
6	DAV	Handshake
7	NRFD	Handshake
8	NDAC	Handshake
9	IFC	Management
10	SRQ	Management
11	ATN	Management
12	SHIELD	Ground
13	DIO5	Data
14	DIO6	Data
15	DIO7	Data
16	DIO8	Data
17	REN (24)*	Management
18	Gnd, (6)*	Ground
19	Gnd, (7)*	Ground
20	Gnd, (8)*	Ground
21	Gnd, (9)*	Ground
22	Gnd, (10)*	Ground
23	Gnd, (11)*	Ground
24	Gnd, LOGIC	Ground

\*Number in parentheses refers to the signal ground return of reference contact number. EOI and REN signal lines return on contact 24.



**Figure 5-5**  
Contact assignments

## 5.4 Interface function codes

The interface function codes, which are part of the IEEE-488 standards, define an instrument's ability to support various interface functions. They should not be confused with programming commands found elsewhere in this manual. Interface function codes for the Model 707A are listed in Table 5-3. The codes define Model 707A capabilities as follows:

**SH1 (Source Handshake)** — SH1 defines the ability of the Model 707A to properly handshake data or command bytes when the unit is a source.

**AH1 (Acceptor Handshake)** — AH1 defines the ability of the Model 707A to properly handshake the bus when it is an acceptor of data or commands.

**T6 (Talker)** — The ability of the Model 707A to send data over the bus to other devices is defined by the T6 function. Model 707A talker capabilities exist only after the instrument has been addressed to talk. T6 means that the Model 707A is a basic talker, has serial poll capabilities, and is unaddressed to talk when it receives its own listen address.

**TE0 (Extended Talker)** — The Model 707A does not have extended talker capabilities.

**L4 (Listener)** — The L4 function defines the ability of the Model 707A to receive device-dependent data over the bus. Listener capabilities exist only after the instrument has been addressed to listen. L4 means that the Model 707A is a basic listener and is unaddressed to listen when it receives its own talk address.

**LE0 (Extended Listener)** — The Model 707A does not have extended listener capabilities.

**SR1 (Service Request)** — The SR1 function defines the ability of the Model 707A to request service from the controller.

**RL1 (Remote Local)** — The RL1 function defines the capabilities of the Model 707A to be placed in the remote or local states.

**PP0 (Parallel Poll)** — PP0 means that the Model 707A does not have parallel polling capabilities.

**DC1 (Device Clear)** — The DC1 function defines the ability of the Model 707A to be cleared (initialized).

**DT1 (Device Trigger)** — The ability for the Model 707A to have setups triggered is defined by the DT1 function.

**C0 (Controller)** — The Model 707A has no controller capabilities.

**E1 (Bus Driver Type)** — The Model 707A has open-collector bus drivers.

**Table 5-3**  
Model 707A interface function codes

Code	Interface function
SH1	Source Handshake capability.
AH1	Acceptor Handshake capability.
T6	Talker (basic talker, serial poll, unaddressed to talk on MLA <sup>1</sup> ).
TE0	No Extended Talker capabilities.
L4	Listener (basic listener, unaddressed to listen on MTA <sup>2</sup> ).
LE0	No Extended Listener capabilities.
SR1	Service Request capability.
RL1	Remote Local capability.
PP0	No Parallel Poll capability.
DC1	Device Clear capability.
DT1	Device Trigger capability.
C0	No Controller capability.
E1	Open-collector bus drivers.

<sup>1</sup> MLA – My Listen Address.

<sup>2</sup> MTA – My Talk Address

## 5.5 Primary address programming

The Model 707A must receive a listen command before it responds to addressed commands. Similarly, the unit must receive a talk command before it transmits data. The Model 707A is shipped from the factory with a programmed primary address of 18. The programming examples included in this manual assume that address.

The primary address may be set to any value between 0 and 30 as long as address conflicts with other instruments are avoided. Note that controllers are also given a primary address, so do not use that address either. Most frequently, controller addresses are 0 or 21, but you should consult the controller's instruction manual for details. Whatever primary address you choose, you must be certain that it corresponds with the value specified as part of the controller's programming language.

To check the present primary address, or to change to a new one, perform the following procedure:

1. Press the MENU button until the current primary address is displayed. For example, if the instrument is set to primary address 18, the following message is displayed:

IEEE-488 18

2. To retain the current address, press CANCEL to exit from the menu.
3. To change the primary address, use the numeric buttons and press ENTER. This stores the new address in memory so that the instrument powers up to that address.

### NOTE

Each device on the bus must have a unique primary address. Failure to observe this precaution will probably result in erratic bus operation.

## 5.6 QuickBASIC programming

Programming examples are written in Microsoft QuickBASIC 4.5 using the Keithley KPC-488.2 (or Capital Equipment Corporation) IEEE interface and the HP-style Universal Language Driver (CECHP).

Before any programming example can be run, the Universal Language Driver must be installed. To install the driver, enter CECHP at the DOS prompt.

If you include the CECHP command in your AUTOEXEC.BAT file, the driver will automatically be installed each time you turn on your computer.

Program fragments are used to demonstrate proper programming syntax. As the name implies, only a fragment of the whole program is used to avoid redundancy. At the beginning of each program, driver files must be opened. The input terminator should be set for CRLF. For example:

```
OPEN "ieee" FOR OUTPUT AS #1
OPEN "ieee" FOR INPUT AS #2
PRINT #1, "interm crlf"
```

A partial list of BASIC statements is shown in Table 5-4.

**Table 5-4**  
BASIC IEEE-488 statements

Action	Basic statement
Transmit string to device 18.	PRINT #1, "OUTPUT 18" ,A\$
Obtain string from device 18.	PRINT #1, "ENTER 18"
Read string.	LINE INPUT #2, A\$
Display string.	PRINT A\$
Send GTL to device 18.	PRINT #1, "LOCAL 18"
Send SDC to device 18.	PRINT #1, "CLEAR 18"
Send DCL to all devices.	PRINT #1, "CLEAR"
Send remote enable.	PRINT #1, "REMOTE"
Cancel remote enable.	PRINT #1, "LOCAL"
Serial poll device 18.	PRINT #1, "SPOLL(18)"
Send local lockout.	PRINT #1, "LOCAL LOCKOUT"
Send GET to device 18.	PRINT #1, "TRIGGER 18"
Send IFC.	PRINT #1, "ABORT"

## 5.7 Front panel aspects of IEEE-488 operation

The following paragraphs discuss aspects of the front panel that are part of IEEE-488 operation, including front panel error messages, IEEE-488 status indicators, and the LOCAL key.

### 5.7.1 Front panel error messages

The Model 707A has a number of front panel messages associated with IEEE-488 programming. These messages, which are listed in Table 5-5, inform you of certain conditions that occur when sending device-dependent commands to the instrument.

The following paragraphs describe the front panel error messages associated with IEEE-488 programming. Note that the instrument may be programmed to generate an SRQ, and U command status words can be checked for specific error conditions if any of these errors occur. See paragraphs 5.9.14 and 5.9.22.

**Table 5-5**

*Front panel IEEE-488 error messages*

Type of error	Description
CARD ID ERROR	Power-up routine cannot identify one or more cards.
IDDC	Illegal device-dependent command received.
IDDCO	Illegal device-dependent command option received.
M/S ERROR	Master/slave communication or timing error.
NOT IN REMOTE	X received while unit is in LOCAL state.
NOT SETTLED	Unit triggered before total settling time expired.
RAM FAIL	Power-up routine or self-test detected RAM error.
ROM FAIL	Power-up routine or self-test detected program ROM checksum error.
SETUP ERROR	Power-up routine detected checksum errors in one or more setups. (Affected setups are cleared.)
TRIG OVERRUN	Unit triggered before Ready bit is set.

### Card identification error

A card ID error occurs when the instrument's power-up routine detects a checksum error in the information from a card. When in master/slave configuration, the cards in error are indicated by all LEDs in their crosspoint display blocks being lit.

### IDDC (illegal device-dependent command) error

An IDDC error occurs when the unit receives an illegal device-dependent command over the bus. For example, the command string 1X includes an illegal command because the "1" is not part of the instrument's programming language.

#### NOTE

When an IDDC error is detected in a command string, all commands in the string, up to and including the next X, are ignored.

To correct the error condition, send only valid commands. Refer to paragraph 5.9 for device-dependent command programming details. An IDDC error is flagged in the U1 word, as discussed in paragraph 5.9.22.

### IDDCO (illegal device-dependent command option) error

Sending the instrument a legal command with an illegal option results in an IDDCO error.

For example, the command K9X has an illegal option (9) that is not part of the instrument's programming language. Thus, although the command K is valid, the option is not, and the IDDCO error results.

#### NOTE

When an IDDCO error is detected in a command string, all commands in the string, up to and including the next X, are ignored.

To correct this error condition, use only valid command options, as discussed in paragraph 5.9. An error is flagged in the U1 word, as discussed in paragraph 5.9.22.

### Master/slave error

A master/slave error occurs when a communication or timing error is detected in the closed loop of units. If one or more errors are detected, the message M/S ERROR is displayed.

To simulate the error condition, disconnect a DIN cable from either of the MASTER/SLAVE connectors. The condition is detected when the Model 707A performs the next operation that requires communication among the units. A master/slave error is flagged in the U1 word, as discussed in paragraph 5.9.22.

### Not in remote error

A not in remote error occurs if the instrument receives an “X” while it is in the local state. This is caused by failing to set the REN line true before addressing the Model 707A to listen. A not in remote error is flagged in the U1 word, as discussed in paragraph 5.9.22.

### Not settled error

A trigger before settling time error occurs when the instrument receives an additional trigger before the settling time has expired. This time period is after assertion of the READY signal and before assertion of the MATRIX READY signal. See paragraph 5.8 for a complete discussion of trigger timing. Both READY and MATRIX READY are bits in the SPOLL byte; MATRIX READY is also a rear panel signal. Note that a master/slave error is also flagged in the U1 word, as discussed in paragraph 5.9.22.

A trigger during this time period is processed normally.

### RAM or ROM failure

A RAM or ROM failure occurs when the power-up routine detects an error, either a RAM error or a checksum error in program ROM. If an error is detected, a RAM FAIL or ROM FAIL message is displayed (cleared by any keypress).

### Setup error

A setup error occurs when the Model 707A power-up routine detects a checksum error in one or more setups stored in non-volatile memory. If an error is detected, SETUP ERROR is displayed and the affected setups are cleared to all open. A keypress will clear this error. Note that a setup error is also flagged in the U1 word, as discussed in paragraph 5.9.22.

### Trigger overrun (hardware) error

A trigger overrun occurs when the instrument is triggered while it is still processing a setup change from a previous trigger and before the READY (for trigger) signal is asserted. READY is a bit in the SPOLL byte. See paragraph 5.8 for a complete discussion of trigger timing. The exact trigger stimulus depends on the selected trigger source, as discussed in paragraph 5.9.21.

Overrun triggers do not affect the instrument except to generate the error. In other words, the present setup change is not aborted by the overrun trigger stimulus, and the trigger is ignored. Note that a trigger overrun error is also flagged in the U1 word, as discussed in paragraph 5.9.22.

## 5.7.2 Status indicators

The TALK, LISTEN, and REMOTE indicators show the present IEEE-488 status of the instrument. Each of these indicators is described below.



**Figure 5-6**  
IEEE-488 indicators

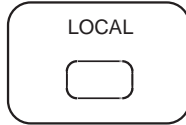
**TALK** — This indicator is on when the instrument is in the talker active state. The unit is placed in this state by addressing it to talk with the correct MTA (My Talk Address) command. TALK is off when the unit is in the talker idle state. The instrument is placed in the talker idle state by sending it an UNT (Untalk) command, addressing it to listen, or with the IFC (Interface Clear) command.

**LISTEN** — This indicator is on when the Model 707A is in the listener active state, which is activated by addressing the instrument to listen with the correct MLA (My Listen Address) command. Listen is off when the unit is in the listener idle state. The unit can be placed in the listener idle state by sending UNL (Unlisten), addressing it to talk, or by sending IFC (Interface Clear) over the bus.

**REMOTE** — This indicator shows when the instrument is in the remote state. Note that REMOTE does not necessarily indicate the state of the REN line, as the instrument must be addressed to listen with REN true before the REMOTE indicator turns on. When the instrument is in remote, all front panel keys except for the LOCAL key are locked out. When REMOTE is turned off, the instrument is in the local state, and front panel operation is restored.

### 5.7.3 LOCAL key

The LOCAL key cancels the remote state and restores local operation of the instrument.



**Figure 5-7**  
LOCAL key

Since all front panel keys except LOCAL are locked out when the instrument is in remote, this key provides a convenient method of restoring front panel operation. Pressing LOCAL also turns off the REMOTE indicator, and returns the display to normal if a message was displayed with the D command. (See paragraph 5.9.5)

Note that the LOCAL key is inoperative if the LLO (Local Lockout) command is in effect.

### 5.7.4 Concurrent front panel and bus operation

Fundamentally, there is no reason why you cannot control the instrument simultaneously from the front panel and over the IEEE-488 bus. However, the following points should be kept in mind.

1. All front panel keys except for LOCAL are inoperative while the Model 707A is in remote (REMOTE on). The unit is placed in remote by addressing it to listen with the REN line true. Thus, to control the unit from the front panel, it is necessary to press LOCAL after programming over the bus. Note that LOCAL is also inoperative if the LLO (Local Lockout) command is in effect.
2. Front panel parameter modification should always be completed before attempting to use bus control. For example, you should not attempt to program a setup over the bus while editing a setup from the front panel.

## 5.8 General bus command programming

### 5.8.1 Overview

General bus commands are those commands (such as DCL) that have the same general meaning regardless of the instrument. Commands supported by the Model 707A are listed in Table 5-8, which also lists BASIC statements necessary to send each command. Note that commands requiring that a primary address be specified assume that the Model 707A primary address is set to 18 (its factory default address).

### 5.8.2 REN (remote enable)

The remote enable command is sent to the Model 707A by the controller to set up the instrument for remote operation. Generally, the instrument should be placed in the remote state before you attempt to program it over the bus. Setting REN true does not actually place the instrument in the remote state. Instead the instrument must be addressed to listen after setting REN true before it goes into remote.



**Table 5-6**  
General bus commands/BASIC statements

Command	Basic statement	Effect on Model 707A
REN	PRINT #1, "REMOTE"	Goes into effect when next addressed to listen.
IFC	PRINT #1, "ABORT"	Goes into talker and listener idle states.
LLO	PRINT #1, "LOCAL LOCKOUT"	LOCAL key locked out.
GTL	PRINT #1, "LOCAL 18"	Cancel remote, restore front panel operation.
DCL	PRINT #1, "CLEAR"	Return to default conditions.
SDC	PRINT #1, "CLEAR 18"	Return to default conditions.
GET	PRINT #1, "TRIGGER 18"	Triggers setup with GET source.

#### NOTE

The instrument need not be in remote to be a talker. All front panel controls (except LOCAL and POWER) are inoperative while the instrument is in remote. You can restore normal front panel operation by pressing the LOCAL key.

### 5.8.3 IFC (interface clear)

The IFC command is sent by the controller to place the Model 707A in the local, talker, and listener idle states. The unit responds to the IFC command by canceling front panel TALK or LISTEN lights, if the instrument was previously placed in one of those states.

### 5.8.4 LLO (local lockout)

The LLO command is used to prevent local operation of the instrument. After the unit receives LLO, all of its front panel controls except POWER are inoperative.

### 5.8.5 GTL (go to local)

The GTL command is used to take the instrument out of the remote state. Operation of the front panel keys will also be restored by GTL unless LLO is in effect. To cancel LLO, you must set REN false.

### 5.8.6 DCL (device clear)

The DCL command may be used to clear the Model 707A and return it to its power-up default conditions (see Table 5-2). Note that the DCL command is not an addressed com-

mand, so all instruments equipped to implement DCL will do so simultaneously. When the Model 707A receives a DCL command, it returns to the power-up default conditions. DCL does not affect the programmed primary address.

### 5.8.7 SDC (selective device clear)

The SDC command is an addressed command that performs essentially the same function as the DCL command. However since each device must be individually addressed, the SDC command provides a method to clear only selected instruments instead of clearing all instruments simultaneously, as is the case with DCL. Any devices on the bus that are addressed to listen are cleared. When the Model 707A receives the SDC command, it returns to the power-up default conditions.

### 5.8.8 GET (group execute trigger)

GET may be used to initiate a Model 707A setup change if the instrument is placed in the appropriate trigger source. Refer to paragraph 5.9 for more information on triggering.

### 5.8.9 SPE, SPD (serial polling)

The serial polling sequence is used to obtain the Model 707A serial poll byte. The serial poll byte contains important information about internal functions, as described in paragraph 5.9.14. Generally, the serial polling sequence is used by the controller to determine which of several instruments has requested service with the SRQ line. However, the serial polling sequence may be performed at any time to obtain the serial poll byte from the Model 707A.

**Table 5-7***Factory default, power-up, and DCL/SDC conditions*

Parameter	Factory default	Power-up, DCL/SDC	Description
Relays	All opened	All opened	—
Stored Setups	All cleared	Not affected	—
Relay Step	000	000	Point to relays
Memory Step	001	001	Point to setup 1
Master/Slave	Stand-alone	(Notes 2, 3)	—
IEEE-488 Address	18 (Note 1)	Not affected	—
External Trigger	A0	A0	Falling edge triggers
Matrix Ready	B0	B0	Negative true
Display	DX	DX	Normal alphanumeric display
Edit Pointer	E0	E0	Point to relays
Trigger Enable	F0	F0	Triggers disabled
Data Format	G0	G0	Full output, all data sent in one talk
EOI/Hold-off	K0	K0	Both enabled
SRQ	M0	M0	Disabled
Digital Output	O000	O000	Output lines low
Programmed Settling Time	S0	S0	0ms
Trigger Source	T7	T7	External trigger
Make/Break Rows	V00000000	Not affected	None selected
Break/Make Rows	W00000000	Not affected	None selected
Terminator	Y0	Y0	<CR><LF>

Notes:

1. The IEEE-488 address is not affected by the Restore (R0) command.
2. Units previously defined as stand-alone or slave will power up as stand-alone units. They become slave units when a master unit initializes a master/slave loop upon power up.
3. DCL/SDC does not affect master/slave state. DCL/SDC does clear slaves.

## 5.9 Device-dependent command (DDC) programming

### 5.9.1 Overview

IEEE-488 device-dependent commands control most instrument operating modes. All front panel modes (such as trigger source and settling time), as well as some modes not available from the front panel (like SRQ and terminator) can be programmed with these commands.

#### Command syntax

Each command is made up of a single ASCII capital letter followed by one or more numbers or letters representing an option(s) of that command. For example, the trigger source can be set over the bus by sending the letter “T” followed by a number representing the trigger option. T1X would be sent to trigger on talk. The IEEE-488 bus treats these commands as data; they are sent with the ATN line false.

Some commands permit more than one option; these must be separated with commas. For example, the close crosspoints commands have the general format:

Crc(,rc)...(,rc)

Here the “rc” options are row and column addresses, while the commas indicate the necessary delimiters. The parentheses indicate that the option and associated delimiter are optional.

#### NOTE

Do not include parentheses in actual command strings.

#### Multiple commands

A number of commands can be grouped together in one command string, which is generally terminated by the “X” character. This character tells the instrument to execute the command or command string as described in paragraph 5.9.25. Commands sent without the X character are not exe-

cuted at that particular time, but they are stored within an internal command buffer for later execution when the X character is finally received.

If a particular command occurs “n” times in a command string, then the “nth” occurrence is the only one used (i.e., T0T2T4X appears to the Model 707A as T4X).

### Invalid commands

If an invalid command is sent as part of the command string, no commands in the string are executed. Under these conditions, the instrument displays a front panel error message (IDDC or IDDCO), as described in paragraph 5.7, and it can be programmed to generate an SRQ (Service Request), as discussed in paragraph 5.9.14. Checking is done as syntactical groups of characters are received.

### Valid command strings (typical samples)

A0X	Single command string.
A0T6X	Multiple command string.
P 0X	Space is ignored
Z15,0X	Multiple-option command string (options separated by commas).

### Invalid command strings (typical samples)

1X	Invalid command as 1 is not a valid command.
K7X	Invalid command option as 7 is not a valid option of the K command.
CA400X	Invalid option (maximum column address is 60).
Z0100X	Multiple-option command without the necessary separating commas.

### Order of command execution

Device-dependent commands are not necessarily executed in the order received. Rather, each instrument always executes them in a specific order. The order of execution for the Model 707A is summarized in Table 5-10. Note that the X command is listed first since it is the character that forces the execution of the rest of the commands.

If you wish to force a particular order of execution, include the execute (X) character after each command option grouping in the command string. For example, the following string would be executed in the received order: T6XA1XR0X.

**Table 5-8**

*Order of command execution*

Order	Command	Description
1	X	Execute DDCs.
2	R	Restore factory default conditions.
3	L	Download setups from controller to Model 707A.
4	E	Set the edit pointer.
5	I	Insert a blank setup in memory.
6	Q	Delete a setup from memory.
7	P	Clear all crosspoints at specified setup.
8	Z	Copy a setup from memory or relays to memory or relays.
9	V	Select rows from make/break.
10	W	Select rows for break/make.
11	N	Open crosspoints of setup indicated by edit pointer.
12	C	Close crosspoints of setup indicated by edit pointer.
13	A	Select trigger edge of External Trigger pulse.
14	B	Select logic sense of Matrix Ready signal.
15	D	Display a user message.
16	F	Enable/disable triggers.
17	G	Select data output format.
18	J	Execute ROM/RAM/display self-test.
19	K	Select EOI and hold-off on X.
20	M	Set the SRQ mask.
21	O	Set the digital output.
22	S	Program the settling time.
23	T	Select the trigger source.
24	U	Request status.
25	Y	Select terminator characters.
26	H	Hit a front panel key.

### Device-dependent command summary

All Model 707A device-dependent commands are summarized in Table 5-11, which also lists respective paragraphs where more detailed information on each command may be found.

**Table 5-9**  
DDC summary

Mode	Command	Description	Para.
External Trigger	A0	Falling edge triggers Model 707A	5.9.2
	A1	Rising edge triggers Model 707A	
Matrix Ready	B0	Negative true Matrix Ready output	5.9.3
	B1	Positive true Matrix Ready output	
Close Crosspoint	Crc(rc)...(rc)	Close crosspoints of setup indicated by edit pointer (rows A-H, columns 1-360)	5.9.4
Display	Dcccccccccccc	Display ASCII character (14 max)	5.9.5
	DX	Return alphanumeric display to normal	
Edit Pointer	E0	Point to present relay setup	5.9.6
	En	Point to stored relay setup (1-100)	
Enable/Disable Triggers	F0	Disable triggers	5.9.7
	F1	Enable triggers	
Data Format	G0	Full output, all data in one talk	5.9.8
	G1	Full output, one switching system row per talk	
	G2 or G3	Inspect output, all data in one talk	
	G4	Condensed output, all data in one talk	
	G5	Condensed output, one switching system per talk	
	G6	Binary output, all data in one talk	
	G7	Binary output, one switching system per talk	
Hit Key	Hn	Emulate front panel key press (1-41)	5.9.9
Insert Blank Setup	In	Insert blank setup in memory (1-100)	5.9.10
Self-test	J0	Perform self-test	5.9.11
EOI and Hold-off	K0	Send EOI, hold-off on X until Ready	5.9.12
	K1	No EOI, hold-off on X until Ready	
	K2	Send EOI, do not hold-off on X	
	K3	No EOI, do not hold-off on X	
	K4	Send EOI, hold-off on X until Matrix Ready	
	K5	No EOI, hold-off on X until Matrix Ready	
Download Setups	Lbbb..X	Download setups from controller to Model 707A	5.9.13
SRQ	M0	SRQ disabled	5.9.14
	M1	Not used	
	M2	Not used	
	M8	Matrix Ready	
	M16	Ready for trigger	
	M32	Error	
	M128	Not used	
Open Crosspoint	Nrc(rc)...(rc)	Open crosspoints of setup indicated by edit pointer (rows A-H, columns 1-360)	5.9.15
Digital Output	Onnn	Set states of digital output lines (000-255)	5.9.16
Clear Crosspoints	P0	Open all crosspoint relays	5.9.17
	Pn	Clear all crosspoints of stored setup (1-100)	
Delete Setup	Qn	Delete setup from memory (1-100)	5.9.18
Restore Defaults	R0	Restore factory defaults	5.9.19
Programmed Settling Time	Sn	Program settling time in milliseconds (0-65000)	5.9.20
Trigger	T0 or T1	Trigger on talk	5.9.21
	T2 or T3	Trigger on GET	
	T4 or T5	Trigger on X	
	T6 or T7	Trigger on External Trigger pulse	
	T8 or T9	Trigger on front panel MANUAL key only	

**Table 5-9 (cont.)**

DDC summary

<b>Mode</b>	<b>Command</b>	<b>Description</b>	<b>Para.</b>
Status	U0	Send machine status word	5.9.22
	U1	Send error status word	
	U2,s	Output setup "s" (0-100) with present G format	
	U3	Send RELAY STEP pointer	
	U4	Send number of slaves	
	U5,u	Send model number of each card in unit "u" (0-4)	
	U6	Send relay settling time	
	U7	Send digital input of unit (0-65535)	
Make/Break	U8	Send RELAY TEST input	5.9.23
	Vabcdefgh	Select rows for make/break operation (abcdefgh = 00000000 to 11111111)	
Break/Make	Wabcdefgh	Select rows for break/make operation (abcdefgh = 00000000 to 11111111)	5.9.24
Execute	X	Execute commands	5.9.25
Terminator	Y0	<CR><LF>	5.9.26
	Y1	<LF><CR>	
	Y2	<CR>	
	Y3	<LF>	
Copy Setup	Z0,n	Copy present relay setup to memory location "n" (1-100)	5.9.27
	Zn,0	Copy setup from memory location "n" (1-100) to relays	
	Zm,n	Copy setup from location "m" (0-100) to location "n" (0-100)	

## 5.9.2 A — External trigger

**Purpose** To select which edge of an external trigger pulse initiates a trigger.

**Format** An

**Parameters** n=0 Falling edge triggers Model 707A  
n=1 Rising edge triggers Model 707A

**Default** Upon power-up or after receiving a DCL, SDC, or R0X command, the instrument defaults to A0 (falling edge).

**Description** The An command lets you program the Model 707A for triggering on a TTL-compatible falling or rising edge signal at the External Trigger input jack. A trigger signal increments the RELAY STEP pointer and copies the setup indicated by the new value from memory to the relays.

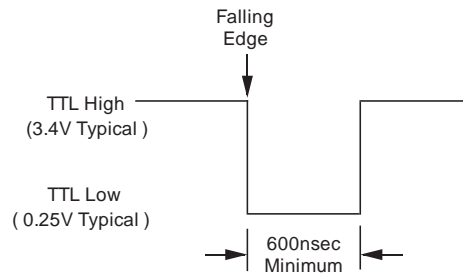
Figure 5-8 shows example trigger pulses. Trigger on external must be the selected source (T command), and triggers must be enabled (F command).

### Programming note

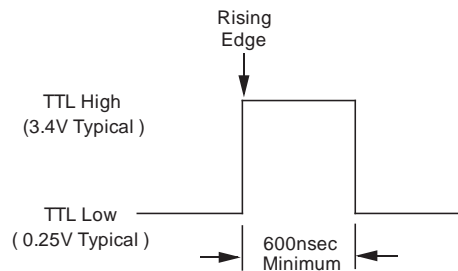
For information on the hardware this command is used with, refer to paragraph 4.11.

### Example

```
PRINT #1, "OUTPUT 18;A1X"      ' Select rising edge pulse to trigger
PRINT #1, "OUTPUT 18;A0X"     ' Select falling edge to trigger
```



A. FALLING EDGE OF PULSE



B. RISING EDGE OF PULSE

**Figure 5-8**  
*External trigger pulse*

## 5.9.3 B — Matrix ready

**Purpose** To select the logic sense of the rear panel Matrix Ready signal.

**Format** Bn

**Parameters** n=0 Negative true Matrix Ready output  
n=1 Positive true Matrix Ready output

**Default** Upon power-up or after receiving a DCL, SDC, or R0X command, the instrument defaults to B0 (negative true).

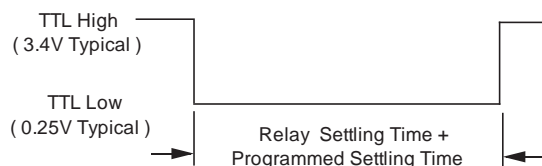
**Description** The B command lets you program the TTL-compatible Matrix Ready output as a high- or low-true signal. This signal goes false when the relays are switched; it goes true after completion of the (hardware) relay settling time and (user) programmed settling time. Figure 5-9 shows example Matrix Ready signals.

**Programming notes**

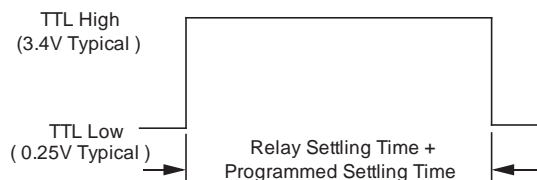
1. The Matrix Ready signal is negated by anything that causes a change to a relay state even if no relays actually change state (e.g., closing an already closed relay).
2. Changing the logic sense of the Matrix Ready signal does not change the logic sense of the Matrix Ready bit in the serial poll byte.

**Example**

```
PRINT #1, "OUTPUT 18;B1X"      ' Select positive true Matrix Ready
PRINT #1, "OUTPUT 18;B0X"     ' Select negative true Matrix Ready
```



A. MATRIX READY HIGH TRUE



B. MATRIX READY LOW TRUE

**Figure 5-9**  
*Matrix ready pulse*

### 5.9.4 C — Close crosspoint

**Purpose** To close crosspoints in a setup.

**Format** Crc(,rc)...(,rc)

**Parameters** r = A to H Row designation of crosspoint  
c = 1 to 360 Column designation of crosspoint (360 with maximum of five Model 707A units)

**Description** The C command closes crosspoints in the setup indicated by the edit pointer. If the edit pointer indicates the present relay setup (zero), the specified crosspoint relays are closed immediately. If the edit pointer indicates a setup stored in memory (1-100), the specified crosspoints are set.

#### Programming notes

1. Do not include parentheses in command strings. They indicate that the option and associated comma delimiter are optional.
2. Up to 25 crosspoints per mainframe can be specified in one close command (with a master and four slaves, the limit is 125 crosspoints). In the same command string, up to 25 crosspoints per mainframe can be opened. If either limit is exceeded, an IDDCO results.
3. The maximum value of the column parameter depends on the configuration (72 for stand-alone, 360 for master with four slave units). An IDDCO results if the maximum value is exceeded.
4. This command is equivalent to multiple light pen operation(s).

#### Example

```
PRINT #1, "OUTPUT 18;CA55X"           ' Close one crosspoint
PRINT #1, "OUTPUT 18;CA55,A56,B49,B50X" ' Close multiple crosspoints
```

### 5.9.5 D — Display

**Purpose** To write messages on the front panel alphanumeric display of a stand-alone or master unit.

**Format** Dcccccccccccc

**Parameters** c = ASCII character (14 maximum)

**Default** Upon power-up, or after receiving a DCL, SDC, or R0X command, the instrument defaults to DX (return alphanumeric display to normal operation).

**Description** The D command allows you to display messages on the front panel alphanumeric display of a stand-alone or master Model 707A. To send a message, simply follow the D command with appropriate ASCII characters. Many displayable ASCII characters can be sent, including numbers or upper case characters. Characters that can be displayed include: 0-9, A-Z, arithmetic and most punctuation symbols.

#### Programming notes

1. As with other device-dependent commands, the D command string should be terminated with the X.
2. Spaces in the command string are displayed.
3. The maximum number of characters is 14; any extra characters in the string are ignored. If there are fewer than 14 characters between the D and X, the characters are left-justified and the rest of the display is blank.
4. To return the alphanumeric display to normal, send DX, perform device clear, or return the Model 707A to the local state.

#### Example

```
PRINT #1, "OUTPUT 18;DMODEL 707AX"    !Display MODEL 707A message
```



### 5.9.6 E — Edit pointer

<b>Purpose</b>	To set the edit pointer	
<b>Format</b>	En	
<b>Parameters</b>	n=0	Present relay setup
	n=1 to 100	Stored relay setup
<b>Default</b>	Upon power-up or after receiving a DCL, SDC, or R0X command, the instrument defaults to E0 (present relay setup).	
<b>Description</b>	With the edit pointer, you can select which setup is affected by subsequent close (C) and open (N) commands. This can be the present relay setup (zero) or one of the stored setups (1-100).	
<b>Programming notes</b>	<ol style="list-style-type: none"> <li>1. The edit pointer value is independent of the Relay Step and Memory Step values.</li> <li>2. When using the edit pointer, it is not necessary to use the COPY key, because you are closing/opening crosspoint relays or setting/clearing stored crosspoints directly and not just turning on/off crosspoint LEDs.</li> </ol>	
<b>Example</b>	<pre>PRINT #1, "OUTPUT 18;E0X" PRINT #1, "OUTPUT 18;E50X"</pre>	<pre>' Point to relays ' Point to stored relay setup 50</pre>

### 5.9.7 F — Enable/disable triggers

<b>Purpose</b>	To enable/disable triggers.	
<b>Format</b>	Fn	
<b>Parameters</b>	n=0	Disable triggers
	n=1	Enable triggers
<b>Default</b>	Upon power-up or after receiving a DCL, SDC, or R0X command, the instrument defaults to F0 (triggers disabled).	
<b>Description</b>	With the F command, you control whether the Model 707A responds to a trigger (from the external trigger connection or over the IEEE-488 bus). A trigger increments the Relay Step pointer and copies the setup indicated by the new value from memory to the relays.	
<b>Programming notes</b>	It is good programming practice to disable triggers before changing the trigger source.	
<b>Example</b>	<pre>PRINT #1, "OUTPUT 18;F0X" • • • PRINT #1, "OUTPUT 18;F1X"</pre>	<pre>' Enable triggers ' Disable triggers</pre>

## 5.9.8 G — Data format

<b>Purpose</b>	To select the output format of the data sent from the present relay setup or a setup stored in memory.														
<b>Format</b>	Gn														
<b>Parameters</b>	<table> <tr> <td>n=0</td> <td>Full output format, all data sent in one talk</td> </tr> <tr> <td>n=1</td> <td>Full output format, one row of one switching system per talk</td> </tr> <tr> <td>n=2 or 3</td> <td>Inspect output format, all data sent in one talk</td> </tr> <tr> <td>n=4</td> <td>Condensed output format, all data sent in one talk</td> </tr> <tr> <td>n=5</td> <td>Condensed output format, one switching system per talk</td> </tr> <tr> <td>n=6</td> <td>Binary output format, all data sent in one talk</td> </tr> <tr> <td>n=7</td> <td>Binary output format, one switching system per talk</td> </tr> </table>	n=0	Full output format, all data sent in one talk	n=1	Full output format, one row of one switching system per talk	n=2 or 3	Inspect output format, all data sent in one talk	n=4	Condensed output format, all data sent in one talk	n=5	Condensed output format, one switching system per talk	n=6	Binary output format, all data sent in one talk	n=7	Binary output format, one switching system per talk
n=0	Full output format, all data sent in one talk														
n=1	Full output format, one row of one switching system per talk														
n=2 or 3	Inspect output format, all data sent in one talk														
n=4	Condensed output format, all data sent in one talk														
n=5	Condensed output format, one switching system per talk														
n=6	Binary output format, all data sent in one talk														
n=7	Binary output format, one switching system per talk														

**Default** Upon power-up or after receiving a DCL, SDC, or R0X command, the instrument defaults to G0 (full output format, all data sent in one talk).

### Description Overview

The G command specifies the format of crosspoint data sent by the Model 707A over the IEEE-488 bus in response to the U2 command. Data concerning the setup is sent by a “U2,n” command (either the present relay setup or a stored setup). You can control the data format and quantity sent. The full, condensed, and binary formats list the open or closed states of every crosspoint in the setup; the inspect format shows only closed crosspoints.

#### G0, G1 = Full output format

With the G0/G1 full output formats, the open or closed states of all crosspoints in a setup are sent in printable ASCII. An ASCII “-” represents an open crosspoint, and an ASCII “X” represents a closed crosspoint. For G0, all data is sent in one talk; for G1, the data from one row of one switching system is sent per talk. An example of these formats is shown in Figure 5-10 for the example setup of Table 5-10.

#### G2, G3 = Inspect output format

With the G2/G3 inspect output formats, the row/column address of each closed crosspoint in a setup is sent in printable ASCII. An ASCII letter (A-H) represents a row, and an ASCII string of up to two numbers (0-60) represents a column. Successive crosspoints are separated with a comma. All data is sent in one talk. Figure 5-11 shows the formats of the example setup in Table 5-10.

#### G4, G5 = Condensed output format

The G4/G5 condensed output formats specify the states of all crosspoints with eight bits representing the eight crosspoints of a column. A set bit indicates a closed crosspoint. The hexadecimal representation of the binary value formed by these eight bits is sent as two printable ASCII characters. For G4, all data is sent in one talk; for G5, the data from one switching system is sent per talk. An example of these formats is shown in Figure 5-12 for the example setup of Table 5-10.

#### G6, G7 = Binary output format

The G6/G7 binary output formats specify the states of all crosspoints with an 8-bit group of bits representing the eight crosspoints of a column. A set bit indicates a closed crosspoint. For G6,

all data is sent in one talk; for G7, the data from one switching system is sent per talk. These formats are shown in Figure 5-13 for the example setup of Table 5-10.

**Table 5-10**  
*Master/slave setup example*

Unit	Closed crosspoints
Master	A1, A2, B3, B5, C7, C8, D9, D10, F11, F12
Slave 1	A13, A14, C15, C16, E17, E18
Slave 2	A25, A26, H27, H30, A36
Slave 3	A37, H38, H43, G48
Slave 4	G49, A50, A51, H55, H56, E57, E60

### Obtaining data

Generally, data is placed into a string or numeric variable. For example, a typical input sequence in BASIC is:

```
PRINT #1, "ENTER 18"
LINE INPUT #2, CROSSPOINT$
```

In this example, the complete crosspoint string is placed in the CROSSPOINT\$ variable.

**Programming notes**

1. Table 5-11 lists the number of bytes that are transmitted for the various data formats.
2. Since the data is transmitted in continuous strings (without carriage returns or line feeds), you must format the data for display or printing legibility.

**Table 5-11**  
*Byte counts for data format*

Format	Stand-alone			Master with four slaves		
	Bytes per talk	Talks per setup	Total bytes	Bytes per talk	Talks per setup	Total bytes
G0	641	1	641	3205	1	3205
G1	79 (Note 1)	9	641	79 (Note 1)	45	3205
G2	(Note 2)	1	(Note 2)	(Note 2)	1	(Note 2)
G3	(Note 2)	1	(Note 2)	(Note 2)	1	(Note 2)
G4	154	1	154	770	1	770
G5	154	1	154	154	5 (Note 3)	770
G6	76	1	76	380	1	380
G7	76	1	76	76	5 (Note 3)	380

Notes:

1. In addition, each unit is identified with a 9-byte ASCII string.
2. This value depends on the number of closed crosspoints.
3. Maximum of five talks, depending on number of slaves in the system.

SETUP 003

```

A  XX-----
B  -----XX---
C  -----XX---
D  -----XX-----
E  -----
F  -----XX-----
G  -----
H  -----
    
```

SLAVE 001

```

A  XX-----
B  -----
C  -----XX-----
D  -----
E  -----XX-----
F  -----
G  -----
H  -----
    
```

CARD 1 COLS.

CARD 6 COLS.

Notes:

1. Slaves 2-4 have the same format as Slave 1.
2. Carriage returns and line feeds are not sent. They are shown here to improve readability.
3. Spacing between columns is one ASCII space.

**Figure 5-10**  
*G0 and G1 full output formats*

A001,A002,B019,B020,C027,C028,D037,D038,F061,F062,A073,A074,C085,C086,E121,E122,A187,A188, H205,H206,A223,A224,H265,H266,G301,G302,A313,A314,H337,H338,E355,E356
---

Note: Carriage returns and line feeds are not sent. They are shown here to improve readability.

**Figure 5-11**  
G2 and G3 inspect output formats

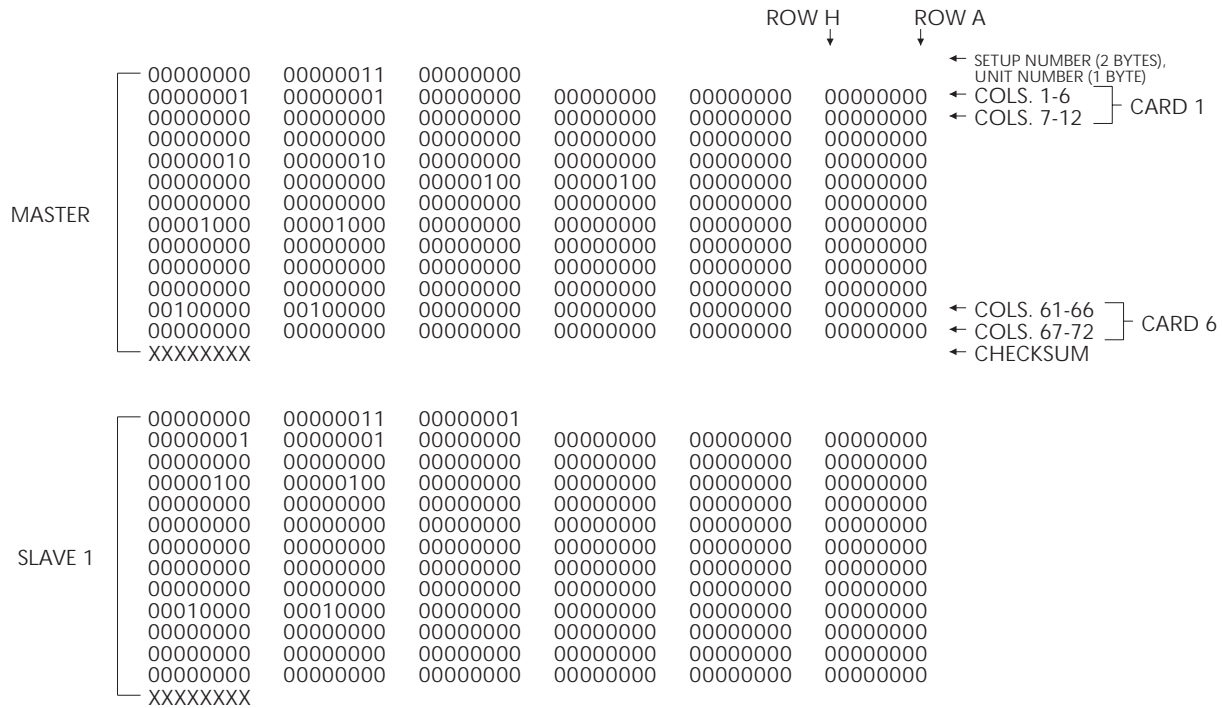
MASTER	[	0003 00		← SETUP NUMBER (2 BYTES), UNIT NUMBER (1 BYTE)
		010100000000	000000000000	← CARD 1, COLS. 1-12
		000000000000	020200000000	
		000004040000	000000000000	
		080800000000	000000000000	
		000000000000	000000000000	
		202000000000	000000000000	← CARD 6, COLS. 61-72
		XX		← CHECKSUM
SLAVE 1	[	0003 01		
		010100000000	000000000000	
		040400000000	000000000000	
		000000000000	000000000000	
		000000000000	000000000000	
		101000000000	000000000000	
		000000000000	000000000000	
		XX		

#### Notes

- Slaves 2-4 have the same format as that shown.
- Carriage returns, line feeds, spaces, and blank lines are not sent. They are shown here to improve readability.
- "XX" represents a 1-byte checksum value (hexadecimal) in printable ASCII.
- The rows that correspond to the G4/G5 data are as follows:

G4/G5 Data	Corresponding Row
00	none
01	A
02	B
04	C
08	D
10	E
20	F
40	G
80	H

**Figure 5-12**  
G4 and G5 condensed output formats



Notes

1. Row A corresponds to the least significant bit of each 8-bit group, Row H to the most significant bit.
2. Slaves 2-4 have the same format as that shown.
3. Data is shown as the binary representation of 8-bit binary numbers. The binary value sent may not correspond to a printable ASCII character.
4. Carriage returns, line feeds, spaces, and blank lines are not sent. They are shown here to improve readability.
5. "XXXXXXXX" represents an 8-bit checksum value in binary.

**Figure 5-13**  
G6 and G7 binary output formats

## 5.9.9 H — Hit key

**Purpose**

To allow emulation of front panel key press sequence.

**Format**

Hn

**Parameters**

The parameter “n” represents the number of the front panel key as shown in the following table.

Command	Key	Command	Key
H1	MEMORY	H22	H
H2	RELAYS	H23	F
H3	COPY DISPLAY → MEMORY	H24	D
H4	COPY DISPLAY → RELAYS	H25	B
H5	AUTOMATIC	H26	7
H6	SCROLL ▲	H27	4
H7	SCROLL ▼	H28	1
H8	INSERT	H29	0
H9	DELETE	H30	8
H10	MENU	H31	5
H11	SETTLING TIME	H32	2
H12	MAKE/BREAK	H33	CANCEL
H13	BREAK/MAKE	H34	9
H14	LOCAL	H35	6
H15	ENABLE	H36	3
H16	SOURCE	H37	ENTER
H17	MANUAL	H38	RESET
H18	G	H39	CLEAR
H19	E	H40	OPEN
H20	C	H41	CLOSE
H21	A		

**Description**

The H command and its options allow you to emulate front panel keystroke sequences. To emulate any such sequence, simply send the appropriate commands in the necessary order.

**Programming notes**

1. The X character must follow each command in a multiple command string.
2. The H command is functional even if LLO (Local Lockout) is in effect.

### 5.9.10 I — Insert blank setup

<b>Purpose</b>	To insert a blank setup in memory.	
<b>Format</b>	In	
<b>Parameters</b>	n=1 to 100	Stored relay setup
<b>Description</b>	During execution of this command, setups “n” through 99 are shifted up to the next highest location in memory (99 to 100, 98 to 99... n to n+1). Then, all crosspoints of setup “n” are cleared. The front panel display is blanked during an insert operation.	
<b>Example</b>	PRINT #1, "OUTPUT 18;I50"	' Insert blank setup at location 50

### 5.9.11 J — Self-test

<b>Purpose</b>	To test ROM and RAM.	
<b>Format</b>	Jn	
<b>Parameters</b>	n=0	Perform self-test
<b>Description</b>	The self-test command starts execution of the ROM and RAM. If an error is detected, a RAM FAIL or ROM FAIL message is displayed. Also, the self-test failed bit is set in the U1 error status word (paragraph 5.9.22). Any front panel keypress or bus command overrides the message.	

#### Programming notes

1. The value “n”, if sent, must be zero.
2. Allow approximately four seconds for the instrument to complete the self-test.
3. The instrument holds off bus operation with the NRFD line during self-test operation. Thus, no commands can be sent during the self-test if hold-off on X is enabled.

<b>Example</b>	PRINT #1, "OUTPUT 18;J0X"	' Perform self-test
----------------	---------------------------	---------------------

### 5.9.12 K — EOI and hold-off

<b>Purpose</b>	To enable/disable EOI and bus hold-off on X.	
<b>Format</b>	Kn	
<b>Parameters</b>	n = 0	Send EOI with last byte, hold-off on X until Ready
	n = 1	No EOI, hold-off on X until Ready
	n = 2	Send EOI with last byte, do not hold-off on X
	n = 3	No EOI, do not hold-off on X
	n = 4	Send EOI with last byte, hold-off on X until Matrix Ready
	n = 5	No EOI, hold-off on X until Matrix Ready
<b>Default</b>	Upon power-up or after receiving a DCL, SDC, or R0X command, the instrument defaults to K0 (send EOI with last byte, hold-off on X until Ready).	



**Description** The EOI line provides one method to positively identify the last byte in the data string sent by the instrument. When enabled, EOI is asserted with the last byte the instrument sends over the bus.

Bus hold-off allows the instrument to temporarily hold up bus operation via the NRFD line when it receives the X character until all commands are processed. The advantage of using bus hold-off is that no commands are missed while the instrument is processing previously received commands. Typical hold-off times are discussed in paragraph 5.11.

**Programming notes**

1. Some controllers rely on EOI to terminate their input sequences. Suppressing EOI may cause the controller input sequence to hang.
2. When reading a buffer, EOI is asserted only at the end of the entire buffer transmission.
3. When enabled, EOI is asserted with the last byte in the terminator.
4. When bus hold-off is enabled, all bus activity is held up for the duration of the hold-off period, not just for the duration of the communication with the Model 707A.

**Example**

```
PRINT #1, "OUTPUT 18;K1X"      ' No EOI, hold-off on X until Ready
PRINT #1, "OUTPUT 18;K2X"      ' Send EOI with last byte, do not hold-off on X
```

### 5.9.13 L — Download setups

**Purpose** To download setups from the controller to the Model 707A.

**Format** Lbbbb...X

**Parameters** bbbb... represents the G4/G5 or G6/G7 output string.

**Description** This command downloads setup information in a G4/G5 or G6/G7 data format. It is used in conjunction with the U2 command (output setup data) to back up or expand the setups stored in the Model 707A.

G formats are discussed in paragraph 5.9.8; see paragraph 5.9.22 for U commands.

**Programming notes**

1. The data format for downloading is specified by the G format presently in effect.
2. The setup data string begins with a setup number and unit number and ends with a checksum value.
3. The setup number is specified in a U2,n command (output setup “n”), as shown in the following programming example.

**Example**

```
DIM SETUP$(32)                ' Dimension for stand-alone
PRINT #1, "REMOTE 18"
PRINT #1, "OUTPUT 18;G4U2,1X"  ' Setup #1 in G4 format
PRINT #1, "ENTER 18"          ' Get setup data
LINE INPUT #2, SETUP$
PRINT SETUP$(1,6)              ' Print setup and unit numbers
PRINT SETUP$(7,30)             ' Print setup data card by card
PRINT SETUP$(31,32)           ' Print checksum
PRINT "PRESS ANY KEY TO CONTINUE" ' Inspect setup data
DO
LOOP WHILE INKEY$= " "          ' Wait for keypress
PRINT #1,"OUTPUT 18;"L"+SETUP$  ' Download setup back to 707A
+"X"18;"L"+SETUP$+"X" "
```

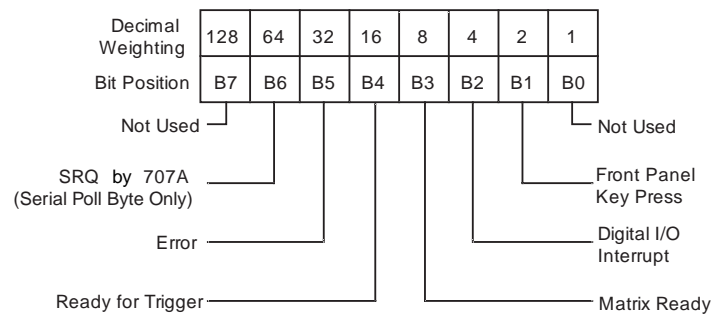
### 5.9.14 M — SRQ and serial poll byte

<b>Purpose</b>	To program which conditions generate an SRQ (service request).
<b>Format</b>	Mn
<b>Parameters</b>	n=0 SRQ disabled n=1 Not used n=2 Not used n=4 Not used n=8 Matrix Ready n=16 Ready for trigger n=32 Error n=128 Not used
<b>Default</b>	Upon power-up or after receiving a DCL, SDC, or R0X command, the instrument defaults to M0 (SRQ disabled).

**Description** The SRQ command selects which conditions cause the Model 707A to generate an SRQ (service request). Once an SRQ is generated, the serial poll byte can be checked to determine if the Model 707A was the instrument that generated the SRQ, and, if so, what conditions caused it.

The general format of the SRQ mask used to generate SRQs is shown in Figure 5-14. By sending the appropriate M command, you can set the appropriate bit(s) to enable SRQ generation if those particular conditions occur. Possible conditions are:

- A front panel key has been pressed (M2).
- An interrupt condition has been received at the Digital I/O port (M4).
- The Matrix Ready signal has been asserted (M8).
- The Ready (for trigger) signal has been asserted (M16).
- An error has occurred (M32). The nature of the error can be determined by reading the UI error word as described in paragraph 5.9.22.



**Figure 5-14**  
SRQ mask and serial poll byte format

## Serial poll byte

The general format of the serial poll byte is shown in Figure 5-14. Note that all bits except for bit 6 correspond to the bits in the SRQ mask. These bits flag the following conditions:

Matrix ready (bit 3) — Set whenever the Matrix Ready signal is asserted. Cleared by the start of relay switching.

Ready for trigger (bit 4) — Set when the Ready signal is asserted. This bit is cleared by:

- Receipt of X.
- Start of relay switching.
- Front panel keypress on master unit.
- Changing Make/Break or Break/Make row.
- Performing self-test.
- Pressing RELAYS key.

### NOTE

Using the H command to “hit” keys could cause the Ready bit to cycle twice: once when the H command is processed and again when the key press is processed.

Error (bit 5) — Set if an error condition occurs. Cleared by reading the U1 error status word (paragraph 5.9.22).

SRQ (bit 6) — Set if the Model 707A requests service via the SRQ line; cleared by a serial poll.

## Programming notes

1. The serial poll byte should be read once the instrument has generated an SRQ to clear the SRQ line.
2. All bits in the serial poll byte latch when the instrument generates an SRQ.
3. If an error occurs, bit 5 (error) in the serial poll byte latches and remains so until the U1 word is read (paragraph 5.9.22).
4. Multiple error conditions can be programmed by adding up the individual command values. For example, send M12X for SRQ under matrix ready and digital I/O interrupt conditions.

## Example

```

PRINT #1, "CLEAR 18"
PRINT #1, "REMOTE 18"           ' Program for SRQ on error
PRINT #1, "OUTPUT 18;M32X"     ' Attempt to program invalid option
PRINT #1, "OUTPUT 18;A2X"     ' Check interface status

WAITSRQ:
IF NOT(srq%) THEN GOTO WAIT SRQ ' Wait for SRQ to occur
PRINT #1, "SPOLL 18"           ' Serial poll the instrument
INPUT #2, S                     ' Read serial poll byte
PRINT "B7 B6 B5 B4 B3 B2 B1 B0" ' Label the bit positions
FOR I=7 TO 0 STEP-1             ' Loop eight times
PRINT BIT (S,I);               ' Display the bit positions
NEXT I
PRINT
PRINT #1, "OUTPUT 18;U1X"     ' Program for error status
PRINT #1, "ENTER 18"           ' Get U1 status to clear error
LINE INPUT #2, ERROR$
PRINT ERROR$                   ' Display error status

```

## 5.9.15 N — Open crosspoint

**Purpose** To open crosspoints in a setup.

**Format** Nrc(,rc)...(,rc)

**Parameters** r=A to H Row designation of crosspoint  
c=1 to 360 Column designation of crosspoint (360 with maximum of five Model 707A units)

**Description** The N command opens crosspoints in the setup indicated by the edit pointer. If the edit pointer indicates the present relay setup (zero), the specified crosspoint relays are opened immediately. If the edit pointer indicates a setup stored in memory (1-100), the specified crosspoints are cleared.

**Programming notes**

1. Do not include parentheses in command strings. They indicate that the option and associated comma delimiter are optional.
2. Up to 25 crosspoints per mainframe can be specified in one open command (with a master and four slaves, the limit is 125 crosspoints). In the same command string, up to 25 crosspoints per mainframe can be closed. If either limit is exceeded, an IDDCO results.
3. The maximum value of the column parameter depends on the configuration (72 for stand-alone, 360 for master with four slave units). An IDDCO results if the maximum value is exceeded.
4. This command is equivalent to multiple light pen operation(s).

**Example**

```
PRINT #1, "OUTPUT 18;NA55X"           ' Open one crosspoint
PRINT #1, "OUTPUT 18;NA55,A56,B49,B50X" ' Open multiple crosspoints
```

## 5.9.16 O — Digital output

**Purpose** To set the states of the digital output lines.

**Format** Ov vv

**Parameters** vv=000 to 255 Decimal value of digital output

**Default** Upon power-up or after receiving a DCL, SDC, or R0X command, the instrument defaults to 0000 (all digital outputs set to logic low).

**Description** This command is a decimal representation of the states of individual output lines of the digital I/O port, where “1” is logic high and “0” is logic low. Bit assignments and corresponding connector pins are shown below:

Bit Position	7	6	5	4	3	2	1	0
Bit Weight	128	64	32	16	8	4	2	1
Digital	8	7	6	5	4	3	2	1

**Programming notes**

1. In a master/slave configuration, only the output of the master unit is updated.
2. Leading zeros are not necessary in the parameter value.
3. This command is equivalent to a multiple light pen operation(s).
4. Output is negative true logic. Setting bit high will make output go low (sink).

**Example**

```
PRINT #1, "OUTPUT 18;O15X"           ' Set bits <3-0> high
PRINT #1, "OUTPUT 18;O0X"           ' Restore default condition
```

### 5.9.17 P — Clear crosspoints

<b>Purpose</b>	To clear all crosspoints at the specified setup.	
<b>Format</b>	Pn	
<b>Parameters</b>	n=0	Present relay setup
	n=1 to 100	Stored relay setup
<b>Description</b>	The P command clears all crosspoints in the setup indicated by its parameter. If the present relay setup (zero) is specified, all crosspoint relays are opened immediately. If setup stored in memory (1-100) is specified, all crosspoints of that setup are cleared.	
<b>Programming note</b>	This command is equivalent to multiple front panel key presses.	
<b>Example</b>	PRINT #1, "OUTPUT 18;P0X"	' Open all relays
	PRINT #1, "OUTPUT 18;P20X"	' Clear relay setup 20

### 5.9.18 Q — Delete setup

<b>Purpose</b>	To delete a setup from memory.	
<b>Format</b>	Qn	
<b>Parameters</b>	n=1 to 100	Stored relay setup
<b>Description</b>	During execution of this command, setups "n+1" through 100 are shifted down to the next lower location in memory ("n+1" to "n"... 100 to 99). Then, all crosspoints of setup #100 are cleared. The front panel display is blanked during a delete operation.	
<b>Programming note</b>	The command Q100 clears all crosspoints of relay setup 100.	
<b>Example</b>	PRINT #1, "OUTPUT 18;Q50X"	' Delete relay setup #50 from memory

## 5.9.19 R — Restore defaults

**Purpose** To restore the Model 707A to factory default conditions.

**Format** Rn

**Parameters** n=0 Restore factory defaults

**Description** An R0 command performs the following actions:

- All setups stored in memory are cleared.
- Make/Break and Break/Make rows are cleared.
- A Device Clear operation (all crosspoint relays are opened, Relay Step pointer is set to 000, Memory Step is set to 001).

DDC parameters are set to the values shown below:

A0	Initiate trigger on falling edge of External Trigger pulse.
B0	Set Matrix Ready output signal to negative true.
E000	Set edit pointer to present relay setup.
F0	Disable triggers.
G0	Set full output format, all data sent in one talk.
K0	Send EOI with last byte, hold-off on X until ready.
M000	Disable all SRQ sources.
O000	Set all digital outputs to logic low.
S00000	Set user settling time to zero.
T7	Trigger Model 707A on external trigger pulse.
V00000000	De-select all rows for make/break.
W00000000	De-select all rows for break/make.
Y0	Set terminator characters of <CR> <LF>.

**Programming note** The primary IEEE-488 address and master/slave operation are not affected by the Restore command.

**Example** PRINT #1, "OUTPUT 18;R0X" ' Restore default conditions, clear setups

## 5.9.20 S — Programmed settling time

**Purpose** To program the settling time.

**Format** Sn

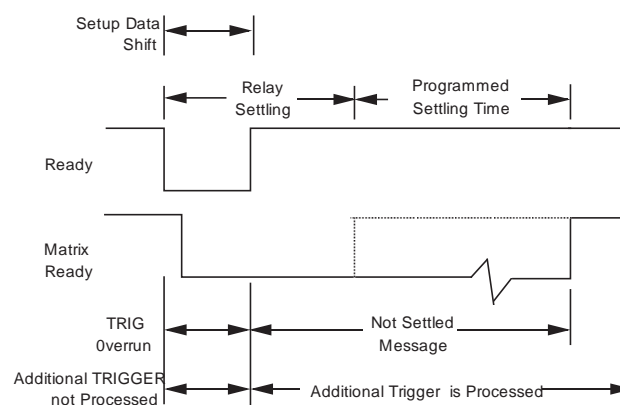
**Parameters** n=0 to 65000 Time in ms

**Default** Upon power-up or after receiving a DCL, SDC, or R0X command, the instrument defaults to S0 (programmed settling time of zero).

**Description** With the S command, you can program the settling time (up to 65 seconds). The programmed settling time starts after the longest relay settling time has elapsed.

**Programming notes**

The total settling time equals the longest relay settling time of any card in the system plus any user-programmed settling time. Figure 5-15 shows a timing diagram of the settling times.



**Figure 5-15**  
*READY and MATRIX READY signal timing*

**Example**

```
PRINT #1, "OUTPUT 18;S5000X"      ' Program 5 second (5000 ms) settling time
PRINT #1, "OUTPUT 18;S0X"        ' Restore default condition (0 ms)
```

**5.9.21 T — Trigger****Purpose**

To select the trigger source.

**Format**

Tn

**Parameters**

n=0 or 1     Trigger on talk  
n=2 or 3     Trigger on GET  
n=4 or 5     Trigger on X  
n=6 or 7     Trigger on External Trigger pulse  
n=8 or 9     Trigger on front panel MANUAL key

**Default**

Upon power-up or after receiving a DCL, SDC, or R0X command, the instrument defaults to T7 (Trigger on External Trigger pulse).

**Description**

With the trigger command, you can determine the trigger source over the bus or from an external trigger pulse. A valid trigger increments the Relay Step pointer by one, stopping at 100, and copies the setup data indicated by the new value to the relays.

**Programming notes**

1. Duplication of trigger sources allows compatibility with other Keithley IEEE-488 instruction sets.
2. Disabling triggers before changing the trigger source is a good programming practice.
3. If the unit is re-triggered while it is still processing a previous trigger, a Trigger Overrun or Trigger Before Settling Time Expired error occurs, depending on when the additional trigger occurs.
4. To trigger the instrument when using the trigger on talk, you must send the talk command derived from the correct primary address. The factory default primary address is 18. Trigger

on talk does not occur when the Model 707A becomes a talker, but rather as the controller requests the first byte of data from the unit.

5. Trigger on GET allows the fastest IEEE-488 triggering response.
6. The X character that is sent when programming a trigger on X source triggers the instrument.
7. Front panel triggering with the MANUAL key is always enabled regardless of the programmed trigger source (while the TRIGGER ENABLE LED is lit); however, all front panel keys are locked out if the unit is in remote (REMOTE on). To restore local operation in this case, press the LOCAL key.

### Example

```
PRINT #1, "OUTPUT 18;F0T0X"      ' Disable triggers, program trigger on talk.
PRINT #1, "OUTPUT 18;F1X"        ' Enable triggers
PRINT #1, "ENTER 18"             ' Trigger next setup
LINE INPUT #2, A$
PRINT #1, "OUTPUT 18;F0T2X"      ' Disable triggers, program trigger on GET
PRINT #1, "OUTPUT 18;F1X"        ' Enable triggers
PRINT #1, "TRIGGER 18"           ' Trigger next setup
```

## 5.9.22 U — Status

### Purpose

To obtain instrument status and system configuration.

### Format

Un  
Un,s  
Un,u

### Parameters

n=0        Send machine status word.  
n=1        Send error status word.  
n=2,s      Output setup “s” (0-100) with present G format.  
n=3        Send value of RELAY STEP pointer.  
n=4        Send number of slaves.  
n=5,u      Send ID of each card in unit “u” (0-4).  
n=6        Send longest relay settling time.  
n=7        Send digital input of unit.  
n=8        Send RELAY TEST input.

### Description

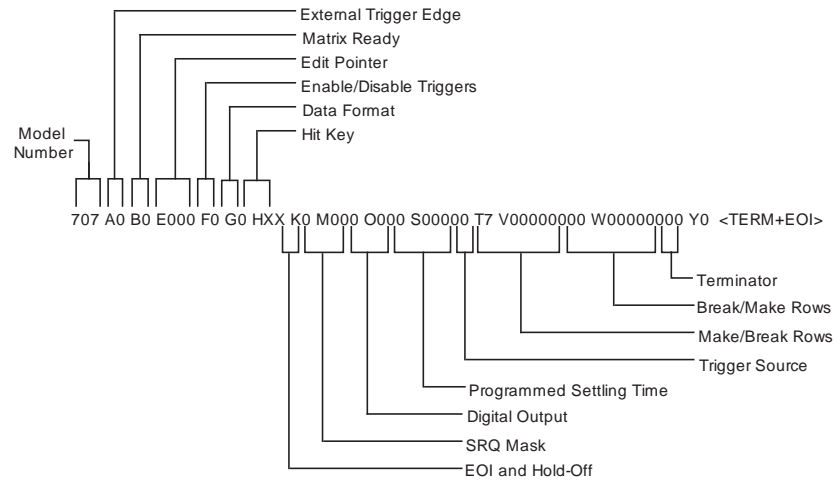
#### Overview

By sending the appropriate U command and then addressing the instrument to talk as with normal data, you can obtain information on machine status, error conditions, and other data.

#### U0 Machine status word

The format of U0 is shown in Figure 5-16. The letters correspond to modes programmed by the respective device-dependent commands. Returned values correspond to the programmed numeric values. The values shown in Figure 5-16 are the default values.

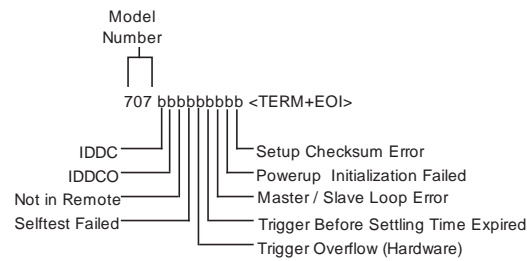




**Figure 5-16**  
U0 machine status word

**U1 Error status word**

The U1 command allows access to Model 707A error conditions. The error status word (Figure 5-17) is a string of ASCII characters representing binary bit positions. Reading the U1 status clears the error bits. An error condition is flagged in the serial poll byte while any bits in the error status word are set. The instrument can be programmed to generate an SRQ when an error condition occurs (see paragraph 5.9.14).



**Figure 5-17**  
U1 error status word

The various bits in the U1 error status word are set when the following conditions are present:

**IDDC** — An invalid device-dependent command (IDDC) is received.

**IDDCO** — An invalid device-dependent command option (IDDCO) is received.

**Not in Remote** — An X command is received over the bus, but the Model 707A is not in remote.

**Self-test Failed** — The self-test detects a program ROM checksum error or a RAM error.

**Trigger Overrun (Hardware)** — A trigger is received before the Ready signal is asserted. The trigger is ignored.

**Trigger Before Settling Time Expired** — A trigger is received before the Matrix Ready signal is asserted. The trigger is processed.

**Master/Slave Loop Error** — There is a communication or timing error in the master/slave loop.

**Power-up Initialization Failed** — The power-up routine has detected a checksum error in the information from one or more cards.

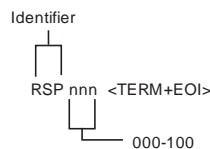
**Setup Checksum Error** — The power-up routine detects a checksum error in one or more setups stored in memory. (The affected setups are cleared.)

### U2,n Formatted setup

With the U2 command, you can request the Model 707A to output data of either the present relay setup ( $n = 0$ ) or a stored setup ( $1 \leq n \leq 100$ ) according to the G format presently in effect. (See paragraph 5.9.8.)

### U3 Relay step pointer

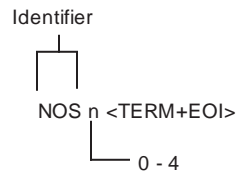
The U3 command (Figure 5-18) requests the value of the Relay Step pointer, which indicates the last setup sent to the relays ( $000 \leq nnn \leq 100$ ).



**Figure 5-18**  
*U3 relay step pointer*

### U4 Number of slaves

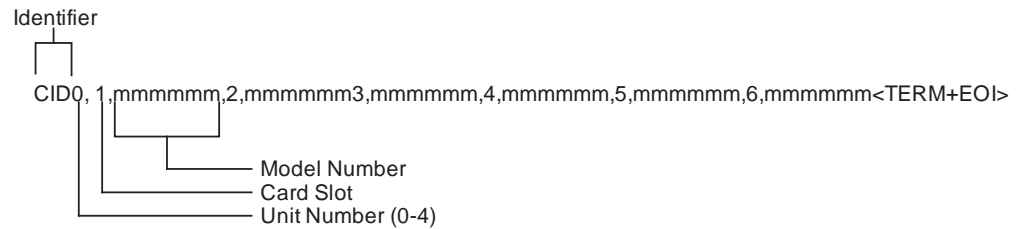
With the U4 command (Figure 5-19), you can request the number of slaves present in a master/slave loop configuration (between 1 and 4).



**Figure 5-19**  
U4 number of slaves

### U5,u Card IDs

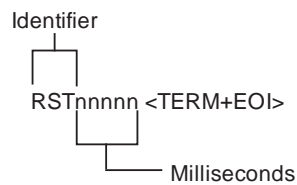
By specifying a unit number in the U5 command (0 for master, 1-4 for slaves), you can request the model numbers of the cards present in each mainframe. The output format is shown in Figure 5-20. The character string for an empty slot is “NONE”.



**Figure 5-20**  
U5 card identification

### U6 Relay settling time

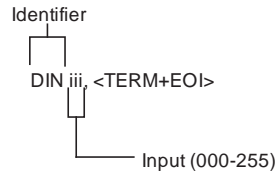
The U6 command (Figure 5-21) requests the Model 707A to output the longest relay settling time of all cards in the system (expressed in milliseconds).



**Figure 5-21**  
U6 relay settling time

### U7 Digital input

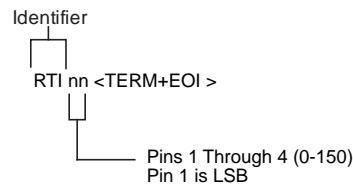
The U7 command (Figure 5-22) requests a decimal value of the inputs at the digital I/O port. In master/slave configurations, the digital input of the master unit is sent.



**Figure 5-22**  
*U7 digital input*

### U8 Relay Test input

The U8 command (Figure 5-23) requests the status of the input pins at the Relay Test connector. Values between 0 and 15 represent the status of pins 1 (LSB) through 4 (MSB).



**Figure 5-23**  
*U8 relay test input*

## Programming notes

1. The instrument transmits the appropriate status word only once each time the corresponding U command is received.
2. To ensure that correct status is indicated, the status word should be requested immediately after the command is transmitted. The status sent by the Model 707A is that which is present at the time it is instructed to talk, not at the time the U command is received.
3. The bits in the U1 error status word latch and remain in that condition until the U1 word is read.
4. The programmed terminator (default CR LF) is transmitted at the end of each status word. Also, EOI is transmitted at the end (unless disabled with the K command).
5. If no U command has been received, the PRINT #1, "ENTER 18" and LINE INPUT #2, A\$ commands request the letter (x) and number (nn) of the software revision for a stand-alone unit or the master unit of a master/slave configuration (707Axnn). It is sent with two trailing spaces plus the terminator and EOI.

## 5.9.23 V — Make/break

**Purpose** To select rows for make/break operation.

**Format** Vabcdefgh

**Parameters** abcdefgh= 00000000 All rows de-selected for make/break  
to  
11111111 All rows selected for make/break

**Description** The V command selects individual rows for make/break (make-before-break) operation. A “1” in the respective row field selects make/break; a “0” de-selects make/break operation.

**Programming notes**

1. Specifying fewer than eight numbers in the parameter field (e.g., V1111) is invalid. The Model 707A takes no action on the rows and flags an IDDCO error.
2. The rows can be programmed for one of three switching options: make/break, break/make, or don't care. A row cannot be selected for both make/break and break/make at the same time. Selecting it for one de-selects it for the other.
3. When switching current sources, use make/break operation to keep current flowing and eliminate switching transients. When switching voltage sources, use break/make operation to avoid momentary shorting of two paths together.
4. Given the present states and actions performed, the next states of the rows are listed below:

<b>Present state</b>	<b>Action</b>	<b>Next state</b>
Don't Care	Select Make/Break	Make/Break
	De-select Make/Break	Don't Care
Make/Break	Select Make/Break	Make/Break
	De-select Make/Break	Don't Care
Break/Make	Select Make/Break	Make/Break
	De-select Make/Break	Break/Make

**Example**

```
PRINT #1, "OUTPUT 18;V11110000X" ' Select rows ABCD for make/break
PRINT #1, "OUTPUT 18;V00000000X" ' Restore default condition
```

## 5.9.24 W — Break/make

**Purpose** To select rows for make/break operation.

**Format** Wabcdefgh

**Parameters** abcdefgh= 00000000 All rows de-selected for break/make  
to  
11111111 All rows selected for break/make

**Description** The W command selects individual rows for break/make (break-before-make) operation. A “1” in the respective row field selects break/make; a “0” de-selects break/make operation.

**Programming notes**

1. Specifying fewer than eight numbers in the parameter field (e.g., W1111) is invalid. The Model 707A takes no action on the rows and flags an IDDCO error.

2. The rows can be programmed for one of three switching options: make/break, break/make, or don't care. A row cannot be selected for both make/break and break/make at the same time. Selecting it for one de-selects it for the other.
3. When switching current sources, use make/break operation to keep current flowing and eliminate switching transients. When switching voltage sources, use break/make operation to avoid momentary shorting of two paths together.
4. Given the present states and actions performed, the next states of the rows are listed below:

Present State	Action	Next State
Don't Care	Select Break/Make	Break/Make
	De-select Break/Make	Don't Care
Make/Break	Select Break/Make	Break/Make
	De-select Break/Make	Make/Break
Break/Make	Select Break/Make	Break/Make
	De-select Break/Make	Don't Care

**Example**

```
PRINT #1, "OUTPUT 18;W11110000X"      ' Select rows ABCD for break/make
PRINT #1, "OUTPUT 18;W00000000X"      ' Restore default condition
```

**5.9.25 X — Execute****Purpose**

To direct the Model 707A to execute device-dependent commands received since the last X.

**Format**

<command> X

**Description**

The execute command is implemented by sending an ASCII X over the bus. Its purpose is to direct the Model 707A to execute other device-dependent commands. Generally, the execute character is the last byte sent in the command string; however, there may be some cases when it is desirable to send a string of characters at one time and then send the execute character later on.

**Programming notes**

1. Commands or command strings sent without the X character are not executed at that time, but they are stored in an internal command buffer for later execution once the X character is finally received.
2. The X character can also be used to trigger, as described in paragraph 5.9.21.
3. Commands are not necessarily executed in the order sent (see Table 5-8). To force a particular command sequence, include the X character after each command in the command string.

**Example**

```
PRINT #1, "OUTPUT 18;E1X"              ' Execute single command
PRINT #1, "OUTPUT 18;E1CA47X"          ' Execute multiple commands
PRINT #1, "OUTPUT 18;T6XA1XR1X"        ' Force command sequence
PRINT #1, "OUTPUT 18;G2Y1"             ' Send string without execute
PRINT #1, "OUTPUT 18;X"                ' Now execute command string at later time
```

## 5.9.26 Y — Terminator

<b>Purpose</b>	To select the ASCII terminator sequence that marks the end of the instrument's data string or status word.
<b>Format</b>	Yn
<b>Parameters</b>	n = 0 <CR><LF> n = 1 <LF><CR> n = 2 <CR> n = 3 <LF>
<b>Default</b>	Upon power-up or after receiving a DCL, SDC, or R0X command, the instrument defaults to Y0 (<CR><LF>).
<b>Description</b>	By using the Y command, you can program the number and type of terminator characters the instrument sends at the end of its data string. Available terminator characters are the commonly used CR (carriage return, ASCII 13) and LF (line feed, ASCII 10) characters. These terminator characters are recognized by most controllers.
<b>Programming notes</b>	<ol style="list-style-type: none"> <li>1. EOI is another method that can be used to terminate the controller input sequence, as discussed in paragraph 5.9.12. EOI is asserted with the last terminator byte when enabled.</li> <li>2. The programmed terminator is sent at the end of the transmission each time the Model 707A is addressed to talk, regardless of the selected data format.</li> <li>3. Status word programming is covered in paragraph 5.9.22</li> </ol> <pre>PRINT #1, "OUTPUT 18;Y2X"           ' Terminator on CR PRINT #1, "OUTPUT 18;Y0X"           ' Restore default</pre>

## 5.9.27 Z — Copy setup

<b>Purpose</b>	To copy a setup from relays or memory to relays or memory.
<b>Format</b>	Zm,n
<b>Parameters</b>	m = 0-100 Copy present relay setup from... n = 0-100 Copy present relay setup to...  0,n = Copy present relay setup to stored setup "n" (1-100) n,0 = Copy stored setup "n" (1-100) to present relay setup m,n = Copy setup "m" (0-100) to setup "n" (0-100)
<b>Description</b>	By specifying a source and destination in the Z command, you can copy data between stored setups and between the relays and setups stored in memory. Copying a setup to the relays sets the Relay Step pointer to that setup.
<b>Programming note</b>	The Z0,0X command sends the present relay setup to the relays. There is no effect on the relays, but the Relay Step pointer will be reset to 000.
<b>Example</b>	<pre>PRINT #1, "OUTPUT 18;Z0,10X"       ' Copy present relay setup to setup 10 PRINT #1, "OUTPUT 18;Z20,0X"       ' Copy setup 20 from memory to relays PRINT #1, "OUTPUT 18;Z10,20X"       ' Copy setup 10 to setup 20</pre>

## 5.10 Relay command combinations

There are four device-dependent commands that have an immediate effect on relay states:

- E0N... — Point to relays, open specified crosspoints.
- E0C... — Point to relays, close specified crosspoints.
- P0 — Open all relays.
- Zn,0 — Copy setup “n” to relays.

Combinations of these commands in the same command string cause only one relay switching operation when the X character is received. The command hierarchy (E, P, Z, N, C) determines the final data that is sent to the relays. This is shown in the following examples.

### Example 1

The command string “E0P0CA1X” sets the edit pointer to the present relay setup, opens all relays, and closes crosspoint A1. A1 will be the only closed crosspoint.

### Example 2

The string “E0Z5,0CA1X” sets the edit pointer to the relays, copies stored setup #5 to the relays, and closes crosspoint A1. A1 will be closed regardless of the state of A1 in setup #5. The status of the relays will be a combination of setup #5 and a closed A1 crosspoint.

### Example 3

The command string “E0Z5,0NA1X” points to the relays, copies setup #5 to the relays, and opens crosspoint A1. If setup #5 had specified A1 to be closed, the command NA1 overrides that. (A1 will not close, then open, as there will be only one relay switching operation.) The relays will reflect setup #5 and an open A1 crosspoint.



## 5.11 Timing considerations

Timing considerations for IEEE-488 programming include:

- Data transfer rates between the controller and Model 707A (stand-alone or master) over the IEEE-488 bus.
- Command string parse time within the stand-alone or master unit.
- Data transfer rates among the units in a master/slave loop.
- Execution times of the tasks defined by device-dependent commands.

The times needed for these actions are determined by the length of the command string, the number of units in a master/slave configuration, the types of commands, and the speed of the controller.

Typically, a command string sent to the Model 707A will transmit at a rate of four characters per millisecond. (Assuming the transfer speed of the controller does not affect the listening rate of the Model 707A.) For example, the CA1,CA5X command string will take 2ms to transmit from the controller to the Model 707A.

When the Model 707A is sending data to the controller (e.g., uploading setup data), the transmission rate will typically be 2.5 characters per millisecond.

The bus hold-off time for each command is the time from receipt of the “X” to “instrument configured.” It includes the parsing time, data transfers within a master/slave loop, and command execution time.

Table 5-12 summarizes the total times (transmission plus hold-off) for device-dependent commands acting on a stand-alone unit. Table 5-13 summarizes these times for a master and one slave system. Bus hold-off times for individual command strings can be calculated by subtracting the transmission time (four characters per millisecond).

**Table 5-12***Typical transmission and hold-off times — stand-alone*

<b>Description</b>	<b>Command</b>	<b>Time</b>	<b>Notes</b>
External Trigger	A0X	4.8ms	
Matrix Ready	B0X	4.8ms	
Close Crosspoint(s)	CA1X	18.6ms	To relays
	CA1X	19.9ms	To setup 55
	CA1,H72X	21.7ms	To relays
	CA1,H72X	23.1ms	To setup 55
Display	D*****X	10.6ms	
	DX	3.8ms	
Edit Pointer	E0X	4.4ms	
	E100X	5.8ms	
Enable/Disable Triggers	F0X	4.8ms	
Data Format	G7X	4.4ms	
Hit Key	H5X	5.3ms	
Insert Blank Setup	I1X	835ms	
	I100X	1.1ms	
Self-test	J0X	3.3ms	
EOI and Hold-off	K0X	4.4ms	
Download Setup	Lbbb...X	56.0ms	Binary format (G6,G7)
SRQ	M32X	4.9ms	
Open Crosspoint(s)			Similar to Close Crosspoints (“C”) times
Digital Output	O255X	5.8ms	
Clear Crosspoints	P0X	18.9ms	
	P55X	20.5ms	
	Q1X	828ms	
Delete Setup	Q100X	21.0ms	
	R0X	628ms	
Restore Defaults	S0X	5.0ms	
Programmed Settling Time	S65000X	7.3ms	
	T7X	4.8ms	
Trigger Source	U0X	4.5ms	
Status	U2,100X	6.8ms	
	V00000000X	124ms	With no B/M rows set
Make/Break Rows	V11111111X	134ms	With no B/M rows set
	V00001111X	153ms	With A,B,C,D as B/M
			Similar to Make/Break Rows (“V”) times
Break/Make Rows			
Execute	X	3.2ms	
Terminator	Y0X	4.7ms	
Copy Setup	Z0,0X	21.1ms	
	Z0,100X	23.3ms	
	Z100,99X	21.6ms	

**Table 5-13***Typical transmission and hold-off times — master and one slave*

<b>Description</b>	<b>Command</b>	<b>Time</b>	<b>Notes</b>
External Trigger	A0X	12.3ms	
Matrix Ready	B0X	12.3ms	
Close Crosspoint(s)	CA1X	31.5ms	
	CA73X	48.7ms	
	CA1,A73X	51.0ms	
Display	D*****X	17.3ms	
Edit Pointer	E0X	17.4ms	
	E55X	18.8ms	
Enable/Disable Triggers	F0X	18.5ms	
Data Format	G0X	11.7ms	
Insert Blank Setup	I1X	1.7s	
	I100X	49.9ms	
Self-test	J0X	3.4ms	
EOI and Hold-off	K0X	11.6ms	
Download Setup	Lbbb...X	68.5ms	Binary format (G6,G7)
SRQ	M32X	12.0ms	
Open Crosspoint(s)			Similar to Close Crosspoints ("C") times
Digital Output	O255X	12.9ms	
Clear Crosspoints	P0X	47.8ms	
	P55X	48.8ms	
Delete Setup	Q1X	1.7s	
	Q100X	49.8ms	
Restore Defaults	R0X	1.4s	
Programmed Settling Time	S0X	11.9ms	
	S65000X	14.6ms	
Trigger Source	T7X	12.3ms	
Status	U0X	11.8ms	
	U2,100X	14.2ms	
Make/Break Rows	V00000000X	265ms	With no B/M rows set
	V11111111X	284ms	With no B/M rows set
	V00001111X	324ms	With A,B,C,D as B/M
Break/Make Rows		10.5ms	Similar to Make/Break Rows ("V") times
Execute	X	11.5ms	
Terminator	Y0X	51.1ms	
Copy Setup	Z0,0X	47.2ms	
	Z0,100X	55.4ms	
	Z100,99X	49.9ms	

# 6

## Principles of Operation

---

### 6.1 INTRODUCTION

This section contains a functional description of the Model 707A in block diagram form as well as details of the various sections of the instrument. Information is arranged to provide a description of each of the functional blocks within the instrument. Many of these descriptions include simplified schematics and block diagrams. Component layout drawings are located at the end of Section 8.

### 6.2 Overall function description

The Model 707A mainframe contains three circuit boards, primarily digital, and a power supply. Relay switching cards that plug into the mainframe have analog circuits for signal paths and digital circuits for control. Figure 6-1 shows the interconnection of the mainframe's digital board, front panel display board, and backplane in a block diagram.

The following paragraphs describe Model 707A circuitry by function, with some functions residing on more than one board (e.g., relay control circuits and display circuits).

### 6.3 Microcomputer

The Model 707A is controlled by an internal microcomputer. As shown in the block diagram of Figure 6-2, the digital board contains the CPU, memory, and associated components:

- 68B09 microprocessor (U6)
- Oscillator (Y1)
- Power-up reset (U17)

- Address decoding PALs (U1, U2)
- 32Kx8-bit EPROM (U7)
- 32Kx8-bit RAM (U8) with battery back-up (BT1, U3)

The microcomputer centers around the 8-bit 68B09 microprocessor. The MPU has direct control over relay switching, front panel displays and switches, and rear panel interfaces (master/slave, digital I/O, IEEE-488 bus, and triggers).

Although the 68B09 microprocessor will operate at frequencies up to 8MHz, a clock frequency of 7.15909MHz is used to reduce interference with instruments that use measurement signals with harmonics of 1MHz. Crystal Y1 provides timing for the microprocessor. Internally, the clock frequency is divided down by four to obtain an operating frequency on the microprocessor bus of 1.78977MHz.

#### 6.3.1 Reset circuit

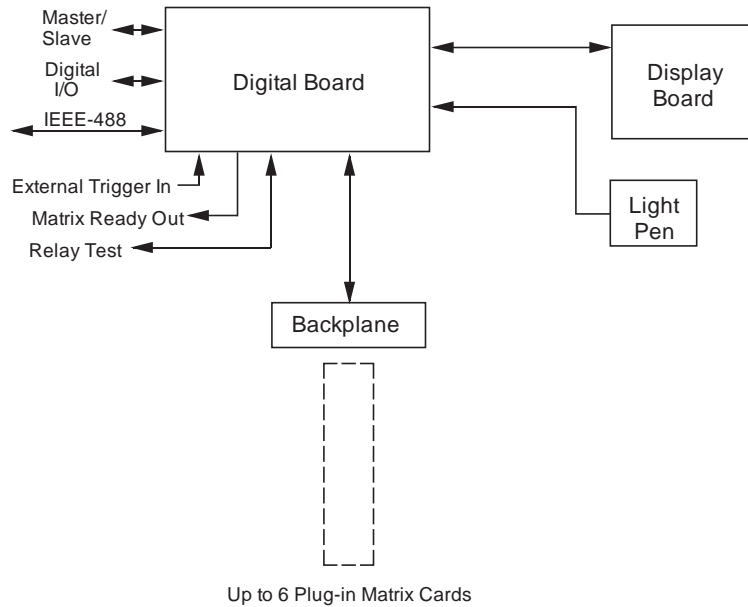
The reset circuit, which is based on an 8211 (or 6728) voltage detector (U17), senses the output of the power supply. When the output drops below approximately 4.6V, the 8211 asserts the RESET (low true) line. Two 1% resistors (R34 and R35) form a voltage divider, which is calibrated to match the comparator threshold voltage of the 8211 by either removing or leaving in R36, which is in parallel with R35.

During power-off or brownout conditions, the RESET line must be asserted before the power supply drops into the comparator threshold range (4.25 to 4.5 volts) of the DS-1210 non-volatile RAM controller (U3). During power-up, capacitor C91 is charged up to delay the RESET line going high for 110 to 260msec.

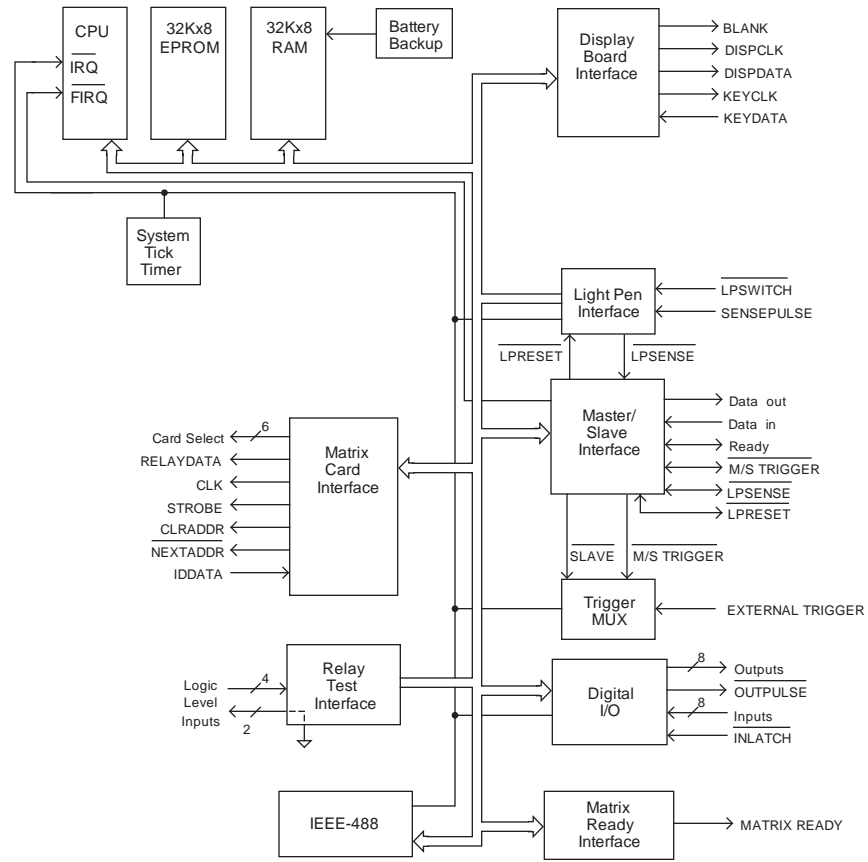
### 6.3.2 Address decoding

U1, a 16P8A programmable array logic (PAL) chip, decodes microprocessor address lines A15-A12 for the 32K EPROM (\$8000-\$FFFF) and the 32K bytes of bank-selected RAM (\$0000-\$2FFF). Bank selection is used so that the RAM appears as 12K bytes of address space to the microprocessor.

U1 also decodes the three bank-select lines (BS3-BS0) from the PB6-PB4 outputs of U9, a 6522A versatile interface adapter (VIA). The RAM is decoded as 8K bytes (\$0000-\$1FFF) and six 4K byte banks, which appear to the microprocessor at addresses \$2000-\$2FFF. This permits the microprocessor to select one of the six 4K byte banks.



**Figure 6-1**  
Model 707A block diagram



**Figure 6-2**  
Digital board block diagram

Address decoding for peripheral devices on the microprocessor bus is performed by another 16P8A PAL (U2). Peripheral devices are decoded at 16-byte intervals in the address range of \$3800-\$38FF. These include, for example, a 6522A-VIA, a 65C21 peripheral interface adapter (PIA), and a 68B50 asynchronous communication interface adapter (ACIA).

### 6.3.3 Memory

The 32K bytes of instrument operation software are stored in U7, which is a 27256 EPROM. The revision level of the software is displayed on power-up.

U8 is a 32K byte static CMOS RAM chip that is used for storing relay setups and as a scratchpad during normal operation. Its power source and chip enable lines are routed through U3, a DS-1210 NVRAM controller. Figure 6-3 shows a simplified schematic of the RAM and battery back-up circuitry.

The NVRAM controller performs the functions of switching the RAM power source between Vcc and the lithium battery (BT1). It also disables chip enable (CE) to the RAM when Vcc is outside the specified limits. (See the paragraph describing the reset circuitry.)

In addition, if the battery power goes below a specified limit while Vcc is not present, a DS-1210 chip normally inhibits the second chip enable signal to the RAM after Vcc is restored. Since this feature is not used in the Model 707A, the software always does a dummy read of memory locations \$0000-\$0001 on power-up to get past the second chip enable cycle. This permits the Model 707A to operate properly with no battery, or if the battery has been replaced.

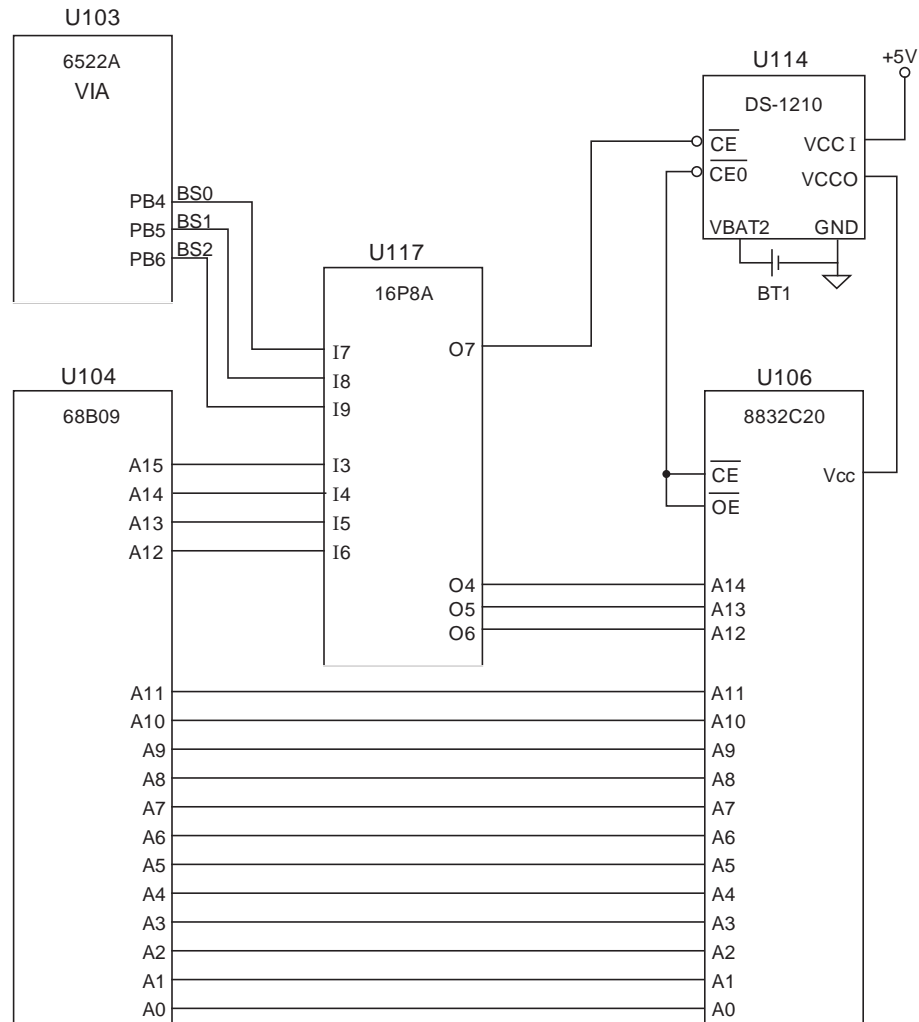
## 6.4 Relay control circuitry

The relay control circuits reside on the backplane board, digital board, and each switching card.

The backplane board acts as a passive conduit for:

- Control signals from the digital board to the switching cards and response from the switching cards to the digital board.
- Power lines to the switching cards.
- Expansion of analog signals among the switching cards.

Operations of relay control circuitry on the digital board and a typical switching card are described in the following paragraphs.



**Figure 6-3**  
RAM and battery backup



### 6.4.1 Switching card interface

A simplified schematic and timing diagram of the digital board's switching card interface are shown in Figures 6-4 and 6-5.

The microprocessor reads card identification data from the EPROM on each installed card during power-up, and also sends relay control data to the cards during the course of operation. This data is sent and received in serial form.

On the digital board, U25, U26, U5, U22, and U24 form an 8-bit parallel-in, serial out data converter. When the microprocessor executes a write to the address decoded for U25 (a 74HCT165 shift register), the data bus contents are loaded into U25, and all ones are loaded into U26 (another 74HCT165) causing its output OH to go high.

At the end of the write cycle, the SELECT RELAYDATA decode line goes high, causing the output of the U5 (74HCT08) AND gate to go high. This signal (ACTIVE) gates the microprocessor E clock through a U22 (74HCT00)

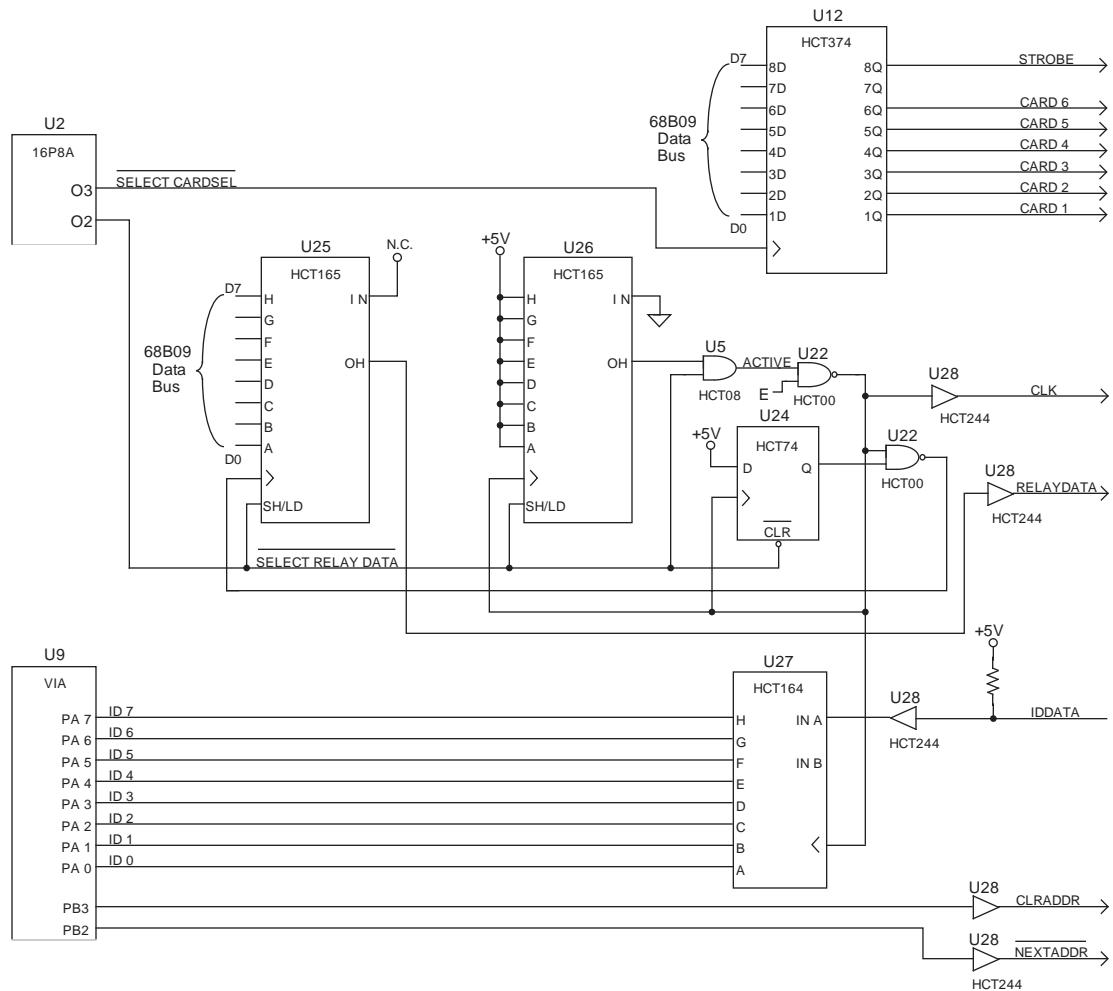
NAND, which is buffered by U28 and sent to the cards as the CLK signal. Clock cycles are counted by the U26 shift register. After 8 cycles, OH of U26 returns low, disabling further CLK pulses.

The U24 (74HCT74) flip-flop and another U22 NAND gate are used to create an inverted version of CLK, which does not start until after one cycle of CLK. This signal is used to shift data out of the U25 RELAYDATA shift register.

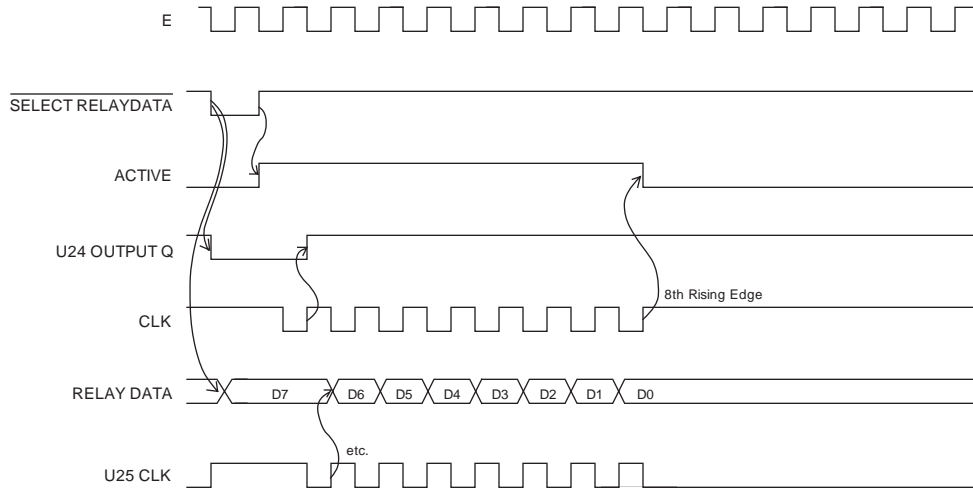
### 6.4.2 Switching card logic

See Figure 6-6 for a block diagram of the logic on a typical switching card.

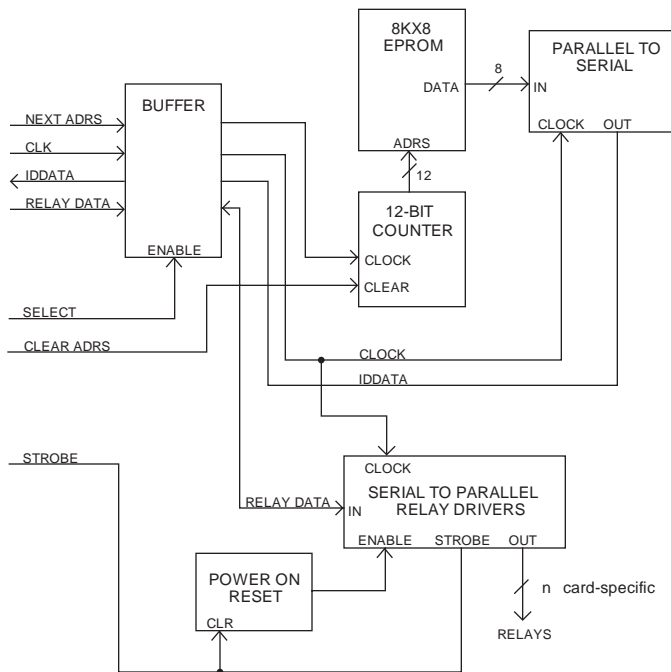
On the cards, the CLK and RELAYDATA signals are buffered and sent to a string of UCN-5841 serial input latched driver chips. The CLK signal is sent in parallel to all of the driver ICs and the serial data out of one driver is connected to the serial data in of the next.



**Figure 6-4**  
Switching card interface simplified schematic



**Figure 6-5**  
Switching card interface timing diagram



**Figure 6-6**  
Typical switching card logic block diagram

## ID data circuits

Each card has a 2764 EPROM that contains the following identification data:

- Card model number
- Relay (hardware) settling time
- Relay configuration table

The configuration table defines the location of each relay driver within the serial RELAYDATA bit stream. The table is necessary because the physical layout of cards varies. In addition, the table accommodates row and/or column isolation relays, such as those on the Model 7072 card.

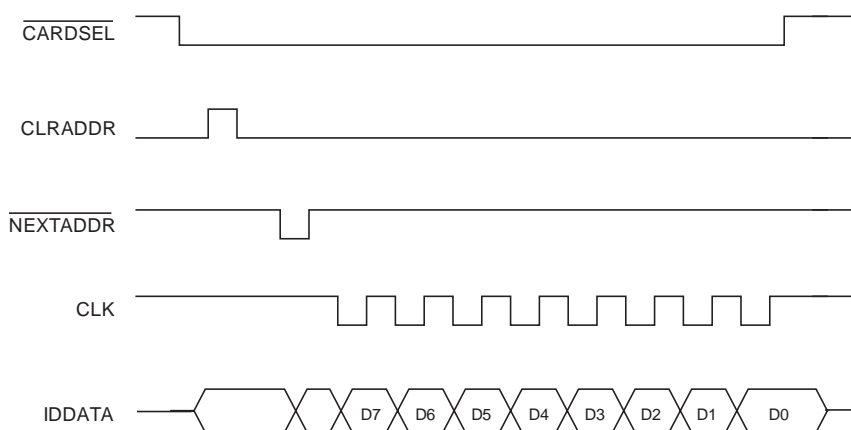
To read this ID data, the sequence below is performed upon power-up. Figure 6-7 shows the general timing of this sequence.

1. The CARSEL line is brought low, enabling the EPROM outputs. This line remains low throughout the ID data transmission sequence.
2. The CLRADDR line (generated by port signal PB3 of the digital boards VIA) is pulsed high to clear the 12-bit address counter (74HCT4040) to zero. At this point, an EPROM address of zero is selected. This pulse occurs only once.

3. The NEXTADDR line (PB2 of VIA) is set low. This increments the counter and enables parallel loading of the parallel-to-serial converter (74HCT165). NEXTADDR is kept low long enough for the counter to increment and the EPROM outputs to stabilize. This sequence functions because the LOAD input of the parallel-to-serial converter is level-sensitive rather than edge-sensitive. The first EPROM address used by the Model 707A is location one, not zero.
4. The same CLK signal that shifts RELAYDATA into the relay driver also clocks the parallel-to-serial converter to shift all eight data bits from the converter to the digital board via the IDDATA line. (This means that a byte of RELAYDATA must be sent to a card to get the next byte of IDDATA.)

Steps 3 and 4 are repeated until all the necessary EPROM locations are read.

As seen in Figure 6-4 of the digital board, IDDATA is converted back to parallel by U27 (74HCT164) and is read by the microprocessor through the port A lines of U9 (6522A VIA).



**Figure 6-7**  
IDDATA timing diagram

## Relay control

The CLK, RELAYDATA, and IDDATA lines are used to all six card slots on the backplane board. A separate card select signal is sent to each card to enable it for receiving RELAYDATA and sending IDDATA. The microprocessor controls the card select signals through U12 (74HCT374) on the digital board, which is decoded as an output port on the microprocessor bus.

The relays are controlled by the serial data transmitted via the RELAYDATA lines. Bytes for each card are shifted serially into latches located in the relay drivers. The serial data is fed in through the DATA lines under control of the CLK signal. As data overflows one register, it is fed out the Q'S line of that register to the next IC down the chain.

Once all the bytes have been shifted into each card in the mainframe, the STROBE line is set high to latch the relay information into the Q outputs of the relay drivers, and the appropriate relays are energized (assuming the driver outputs are enabled, as discussed below). Logic convention is such that the corresponding relay driver output must be low to energize the associated relay, while the output is high when the relay is de-energized. The STROBE signal is received by all cards regardless of the state of their respective card select lines.

## Power-on safeguard

Each card has a power-on safeguard circuit to ensure that relays do not randomly energize upon power-up. Two NAND gates of a 74HCT00 are configured as an R-S flip-flop. On power-up, the Q output of the flip-flop is set high, holding the low true OEN (output enable) pins of the relay drivers high. Hence, the driver outputs are disabled and all relays remain de-energized regardless of the relay data information present at that time.

The falling edge of the first STROBE pulse that comes along (to load relay data) clears the R-S flip-flop, setting the OEN pins low and enabling the driver outputs. (At this time, valid relay control data has been sent to the cards and is present in the latches of the driver chips.) This action allows the relays to be controlled by the transmitted relay data information.

## NOTE

The STROBE signal can be high or low on power-up since the outputs of U12 (74HCT374) on the digital board are undefined at power-on. Since a falling edge on STROBE, after the Output Enable circuit times out, enables the relay driver outputs, the power-up software must set STROBE low before the time-out. It then pulses STROBE high only after the relay driver shift registers have been cleared.

A hold-off period (typically 470msec) is included in the safeguard circuit to guard against premature enabling of the relays. The time constant of the hold-off period is determined by an R-C network.

## 6.5 Display circuitry

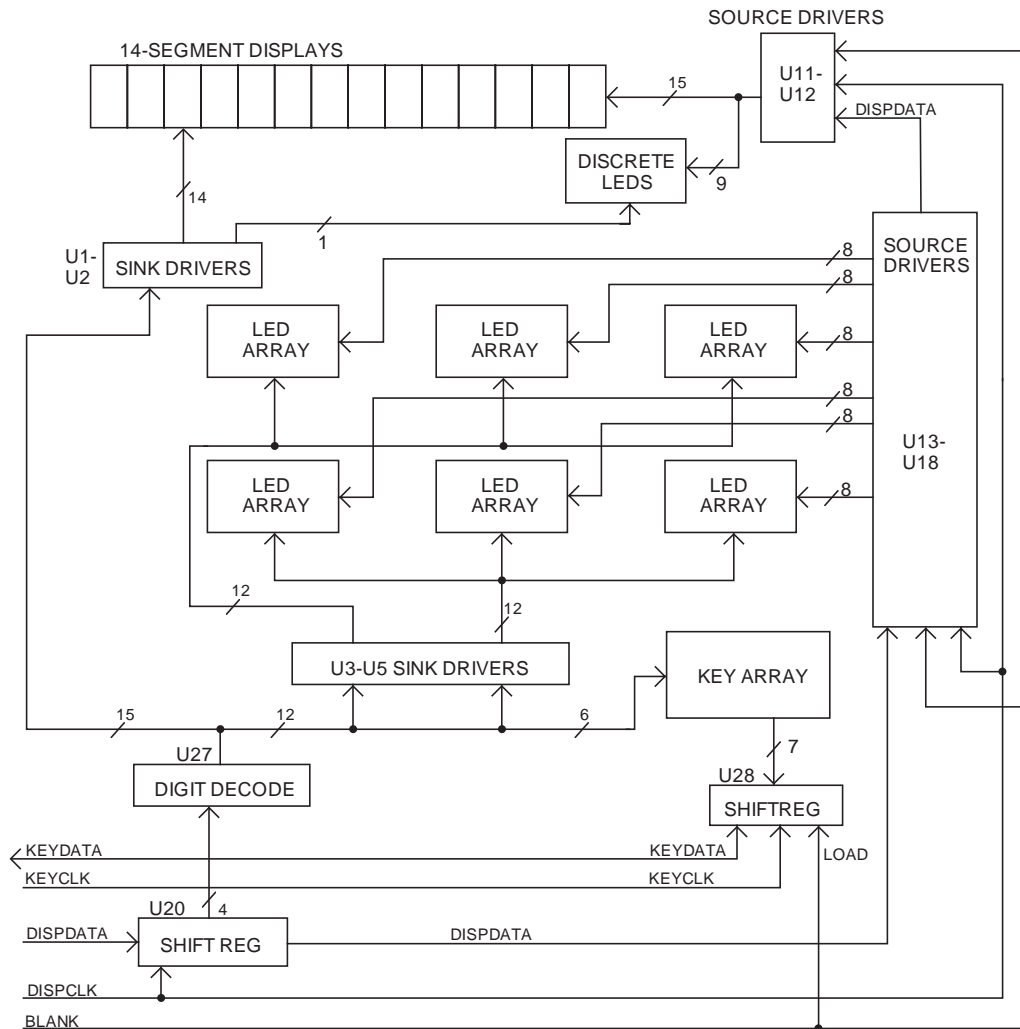
Model 707A display circuitry includes components needed to control the alphanumeric display, front panel annunciator LEDs, crosspoint LEDs, make/break and break/make LEDs, and needed to read front panel switches.

The display circuitry resides on the display board and digital board. See Figure 6-8 for a block diagram of the display board and Figure 6-9 for a simplified schematic of the display board interface on the digital board.

The front panel display is multiplexed as 15 columns of up to 63 segments each:

- There are 14 columns of alphanumeric display digits, plus a 15th column containing the discrete annunciator LEDs (TALK, LISTEN, REMOTE, MEMORY, RELAYS, etc.).
- There are 12 columns of crosspoint display LEDs. They line up under the right-most 12 alphanumeric digits.
- There is one column of Make/Break and Break/Make LEDs. It lines up under the column containing the discrete annunciators.

The first 15 display segments are the 14-segment plus decimal point alphanumeric digits (in columns 1-14), or the discrete annunciators (in column 15). The remaining 48 display segments are divided into six groups of eight, one group for each block of crosspoint displays (for columns 1-12), or for the Make/Break and Break/Make LEDs (for column 15). Segment assignments for the multiplexed columns are shown in Table 6-1.

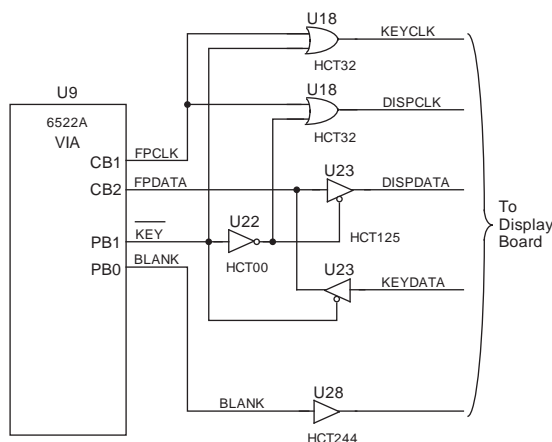


**Figure 6-8**  
Display board diagram

**Table 6-1**  
Display segment assignments

Display Segments	Display MUX Columns							
	15	14	13	12	11	10	9	8
1-15	Annunciator LEDs DS32-DS40	Alphanumeric digit 1 DS1 (MSD)	Alphanumeric digit 2 DS1	Alphanumeric digit 3 DS2	Alphanumeric digit 4 DS2	Alphanumeric digit 5 DS3	Alphanumeric digit 6 DS3	Alphanumeric digit 7 DS4
16-23	Upper make/break LEDs DS8-DS9			Card 1 column 1 DS8-DS9	Card 1 column 2 DS8-DS9	Card 1 column 3 DS8-DS9	Card 1 column 4 DS8-DS9	Card 1 column 5 DS8-DS9
24-31				Card 2 column 1 DS12-DS13	Card 2 column 2 DS12-DS13	Card 2 column 3 DS12-DS13	Card 2 column 4 DS12-DS13	Card 2 column 5 DS12-DS13
32-39	Upper break/make LEDs DS18-DS19			Card 3 column 1 DS16-DS17	Card 3 column 2 DS16-DS17	Card 3 column 3 DS16-DS17	Card 3 column 4 DS16-DS17	Card 3 column 5 DS16-DS17
40-47	Lower make/break LEDs DS20-DS21			Card 4 column 1 DS20-DS21	Card 4 column 2 DS20-DS21	Card 4 column 3 DS20-DS21	Card 4 column 4 DS20-DS21	Card 4 column 5 DS20-DS21
48-55				Card 5 column 1 DS24-DS25	Card 5 column 2 DS24-DS25	Card 5 column 3 DS24-DS25	Card 5 column 4 DS24-DS25	Card 5 column 5 DS24-DS25
56-63	Lower break/make LEDs DS30-DS31			Card 6 column 1 DS28-DS29	Card 6 column 2 DS28-DS29	Card 6 column 3 DS28-DS29	Card 6 column 4 DS28-DS29	Card 6 column 5 DS28-DS29
Display Segments	Display MUX columns							
	7	6	5	4	3	2	1	
1-15	Alphanumeric digit 8 DS4	Alphanumeric digit 9 DS5	Alphanumeric digit 10 DS5	Alphanumeric digit 11 DS6	Alphanumeric digit 12 DS6	Alphanumeric digit 13 DS7	Alphanumeric digit 14 DS7 (LSD)	
16-23	Card 1 column 6 DS10-DS11	Card 1 column 7 DS10-DS11	Card 1 column 8 DS10-DS11	Card 1 column 9 DS10-DS11	Card 1 column 10 DS10-DS11	Card 1 column 11 DS10-DS11	Card 1 column 12 DS10-DS11	
24-31	Card 2 column 6 DS12-DS13	Card 2 column 7 DS12-DS13	Card 2 column 8 DS12-DS13	Card 2 column 9 DS12-DS13	Card 2 column 10 DS12-DS13	Card 2 column 11 DS12-DS13	Card 2 column 12 DS12-DS13	
32-39	Card 3 column 6 DS16-DS17	Card 3 column 7 DS16-DS17	Card 3 column 8 DS16-DS17	Card 3 column 9 DS16-DS17	Card 3 column 10 DS16-DS17	Card 3 column 11 DS16-DS17	Card 3 column 12 DS16-DS17	
40-47	Card 4 column 6 DS22-DS23	Card 4 column 7 DS22-DS23	Card 4 column 8 DS22-DS23	Card 4 column 9 DS22-DS23	Card 4 column 10 DS22-DS23	Card 4 column 11 DS22-DS23	Card 4 column 12 DS22-DS23	
48-55	Card 5 column 6 DS24-DS25	Card 5 column 7 DS24-DS25	Card 5 column 8 DS24-DS25	Card 5 column 9 DS24-DS25	Card 5 column 10 DS24-DS25	Card 5 column 11 DS24-DS25	Card 5 column 12 DS24-DS25	
56-63	Card 6 column 6 DS28-DS29	Card 6 column 7 DS28-DS29	Card 6 column 8 DS28-DS29	Card 6 column 9 DS28-DS29	Card 6 column 10 DS28-DS29	Card 6 column 11 DS28-DS29	Card 6 column 12 DS28-DS29	

Note:  
MSD — Most significant digit  
LSD — Least significant digit



**Figure 6-9**  
Display interface simplified schematic

### 6.5.1 Display data

The digital board sends display data (DISPDATA) to the display board serially. Nine bytes are required: eight bytes of segment data and one byte to select the column.

All displays are arranged as common cathode. The segment anodes are driven by source drivers U11-U18 (UCN5895A) connected in a serial data chain. Each source driver has eight outputs and an output disable. (While new data is being sent to the display drivers, the BLANK line is set high to disable the outputs.) Display data is first shifted into serial-to-parallel converter U20 (74HCT164) and then to the chain of segment source drivers.

Four parallel outputs of U20 are decoded by the 4-to-16 decoder U27 (74HCT154). The outputs of this decoder drive the display cathodes through sink drivers U1-U5 (UDN2597A).

### 6.5.2 Front panel keys

The front panel keys are SPST normally-open pushbutton switches. They are connected in a 6-column by 7-row array. Each column is connected to one of the column drive outputs of decoder U27 (74HCT154) through a diode. The diodes isolate the columns from one another in case more than one key on the same row is pressed. As the display is multiplexed, each key column is pulled low in its turn. The other columns float.

Each row is connected to Vcc through a pull-up resistor and to one of the inputs of parallel-to-serial converter U28 (74HCT165). The load input of U28 is connected to the BLANK signal, so that each time new data is sent to the display, another column of the key array gets latched into U28.

### 6.5.3 Display interface

The display interface circuitry of the digital board generates clock signals and communicates serial data for the front panel display and keyboard. The shift register of U9 (6522A VIA) controls the display and reads the key array. Pin CB1 is the clock signal (FPCLK) and pin CB2 is the data signal (FPDATA).

Signal FPCLK is generated for both serial output (display) and serial input (keyboard) operations. This single bi-directional port is converted to two uni-directional ports by two OR gates of U18 (74HCT32), two tri-state drivers of U23 (74HCT125), and a NAND gate of U22 (74HCT00) used as an inverter.

When the low true KEY signal (generated on VIA pin PB1) is asserted, DISPCLK is held high, KEYCLK follows FPCLK, the KEYDATA driver (U23) is enabled, and the DISPDATA driver (U23) is disabled.

When the low true KEY signal is negated, the KEYCLK signal is held high and the DISPCLK signal follows FPCLK. Also, the KEYDATA driver is disabled while the DISPDATA driver is enabled. The remaining signal that goes to the display board, BLANK, is generated by VIA output pin PB0.



### 6.5.4 Refresh display/read keyboard

The refresh display/ read keyboard sequence is as follows:

**NOTE**

During power-on hardware initialization, the U9 shift register (6522A VIA) is configured for Output and the low true KEY signal is negated.

1. Set the BLANK line high.
2. Send nine bytes of DISPDATA out the VIA shift register to drive the next column in the multiplex sequence.
3. Set the BLANK line low.
4. Configure the VIA shift register for input.
5. Assert the low true KEY line.
6. Read the VIA shift register to cause the KEYDATA to be shifted into the VIA.

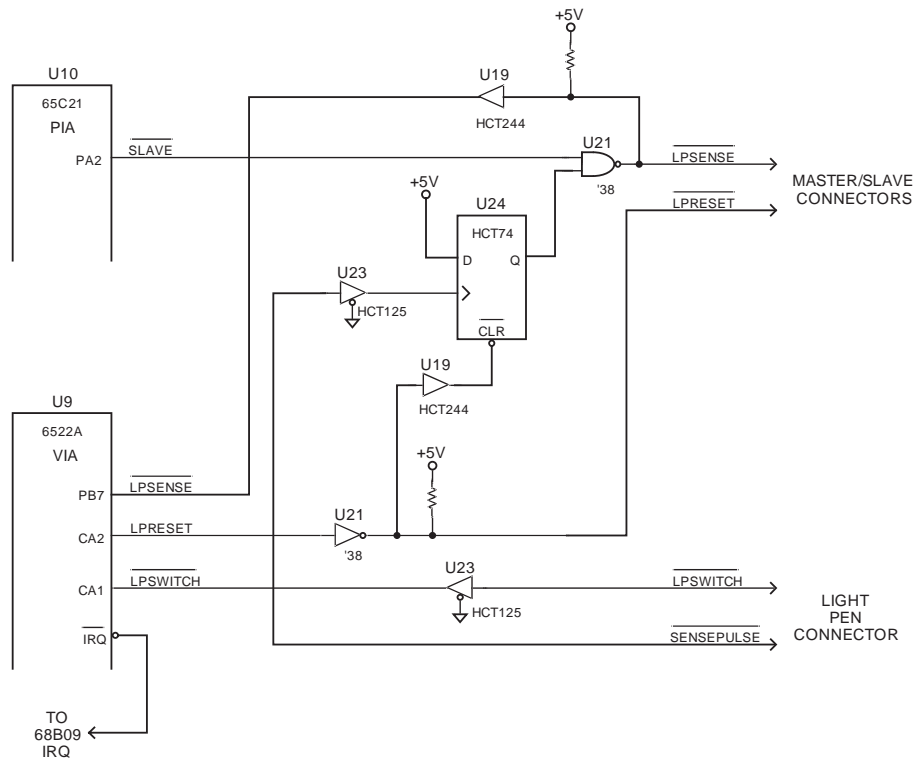
7. Read the VIA shift register again to get the byte of KEY-DATA.
8. Negate the low true KEY line.
9. Configure the VIA shift register for output.

### 6.6 Light pen interface

The light pen interface circuitry resides on the digital board. A simplified schematic is shown in Figure 6-10.

The light pen is a self-contained unit requiring only a 5-volt supply. It returns two TTL-compatible signals:

- SENSEPULSE — A low-going pulse of about 15µsec width that occurs as the light intensity at the end of the pen rises above a preset threshold.
- LPSWITCH — A debounced switch signal that is low while the light pen pushbutton is depressed.



**Figure 6-10**  
Light pen interface simplified schematic

The rising edge of SENSEPULSE clocks a high into flip-flop U24 (74HCT74). This converts the signal into a level that can be read by the microprocessor through the PB7 input of U9 (6522A VIA) as signal LPSENSE (low true).

If the low true SLAVE signal from U10 (65C21 PIA) is high (i.e., the unit is either a stand-alone or master), the microprocessor reads its own U24 flip-flop. The output of U24 also gets driven onto the LPSENSE line of the master/slave connectors. If SLAVE is asserted, the microprocessor reads the LPSENSE signal from the master/slave connectors.

The microprocessor can clear flip-flop U24 by setting the LPPRESET output of U9 high. This signal also gets driven onto the master/slave connectors by open-collector driver U21. This method permits the master and all slaves in a master/slave system to read and clear the U24 flip-flop in the master unit. Thus, one light pen can serve for all units, while each unit controls its own display for the scan routine.

The switch signal (low true LPSWITCH) goes to the CA1 interrupt input of the VIA, which is programmed to generate an IRQ interrupt on the falling edge of LPSWITCH. The interrupt service routine stops the normal display refresh multiplexing and takes over control of the display.

The routine then scans the display one column at a time, clearing flip-flop U24 before scanning each column. After the display is scanned, the processor examines the LPSENSE signal to determine if the light pen “sees” one of the LEDs that is currently being scanned.

If a master scans its display and gets no response from the light pen, it instructs the slaves in turn to scan their displays. Each slave monitors the U24 flip-flop of the master to check whether or not the light pen “sees” any of the LEDs that are lit on its own display.

## 6.7 Master/slave circuitry

The master/slave interface is a closed loop of serial communication and bused control signals. Its control circuitry resides on the digital board. See Figure 6-11 for a simplified schematic.

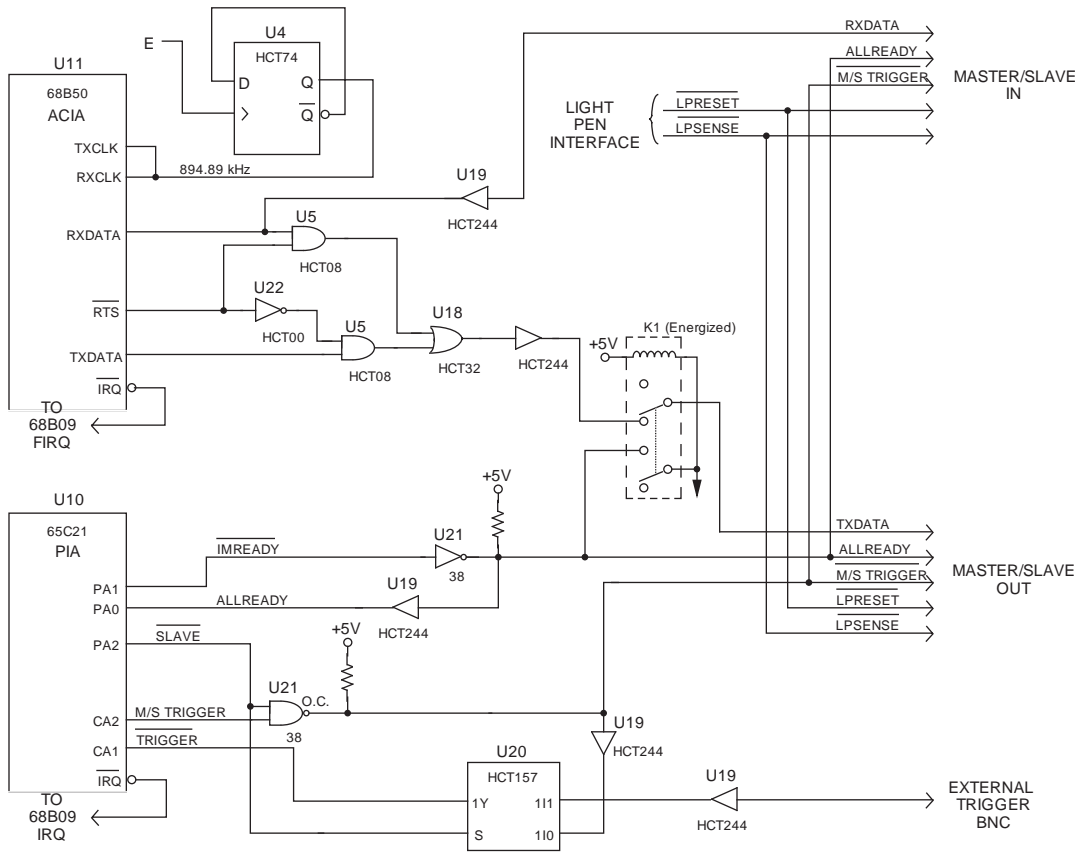
Each mainframe has a Master/Slave In connector and a Master/Slave Out connector. Serial data is sent from the TXDATA pin of the output connector to the RXDATA pin of the input connector on the next mainframe in the loop. All other interface signals (M/S TRIGGER, ALLREADY, LPPRESET, and LPSENSE) are common to input and output connectors. The light pen signals LPPRESET and LPSENSE are described in paragraph 6.6.

### 6.7.1 Serial communication

Serial data communication is managed by U11 (68B50 ACIA) and automatic retransmit logic: a U22 NAND gate used as an inverter, U5 AND gates, and U18 OR gate.

The RTS (low true) output of U11 controls the automatic retransmission of serial data. Stand-alone and master units assert RTS to gate the TXDATA output of U11 through a U5 AND gate and via U18 onto the TXDATA pin of the master/slave interface. Relay K1 is energized (as shown) whenever power is applied to the Model 707A.

Slave units negate RTS except when responding to a request by the master for setup or status information. A negated RTS signal blocks the TXDATA signal at its corresponding U5 AND gate. Incoming serial data to the RXDATA input of U11 is also routed through a U5 gate, the U18 OR gate, and onto the master/slave TXDATA pin to effect the automatic retransmission.



**Figure 6-11**  
Master/slave interface simplified schematic

## 6.7.2 Control signals

Bused control signals are managed by U10 (65C21 PIA). Bused outputs are driven by U21 (7438 open-collector NAND) and are buffered for input with U19 receivers.

The SLAVE (low true) signal selects the external trigger source:

- In slave units, the SLAVE signal is asserted. This causes multiplexer U20 to select the M/S TRIGGER (low true) signal for the trigger interrupt. Slaves are disabled from driving the M/S TRIGGER signal by the U21 NAND.
- In master or stand-alone units, SLAVE is negated and multiplexer U20 selects the External Trigger Input BNC for the trigger interrupt. This also enables the unit to drive the M/S TRIGGER signal via the U21 NAND.

The ALLREADY signal is wire-ORed so that it is negated whenever any unit in the master/slave loop has negated its IMREADY (low true) signal when receiving and processing data. When a slave unit is powered down, relay K1 provides a path to digital ground, simulating a negated IMREADY signal. This provides positive indication to other units on the master/slave loop that one of the units is not running. (Power-up software waits until all units have asserted their IMREADY signal.)

Assertion of M/S TRIGGER when the ALLREADY signal is false causes the slave units to reset to a known state. (Asserting M/S TRIGGER with ALLREADY true triggers the slaves.)

## 6.8 Digital I/O

The digital input and digital output ports are two separate interfaces, even though they are on the same DB25 connector. A simplified schematic of the circuitry is shown in Figure 6-12.

Digital inputs are managed by U13 (74HCT373 transparent latch), which is decoded as a port on the microprocessor bus by PAL U2. U13 latches in the states of lines IN (0:7) whenever the INLATCH (low true) signal is asserted or the microprocessor reads the digital input port.

To cause the microprocessor to read the input lines, the INLATCH signal is also routed to the CB1 input of U10 (65C21 PIA), which is programmed to generate an interrupt on a falling edge.

Digital outputs are managed by port B of U10. The OUT-PULSE (low true) signal on pin CB2 is asserted for about one E clock cycle (600nsec) after the microprocessor has written to the port B output lines OUT (0:7).

## 6.9 IEEE-488 bus interface

The Model 707A has an IEEE-488 standard interface that allows the instrument to be programmed from a system controller. Commands can be sent over the bus to the instrument and data can be requested from the instrument.

The IEEE-488 interface is made up of U14, U15, and U16. U14 is a 9914A GPIA (general purpose interface adapter), while U15 and U16 are interface bus drivers.

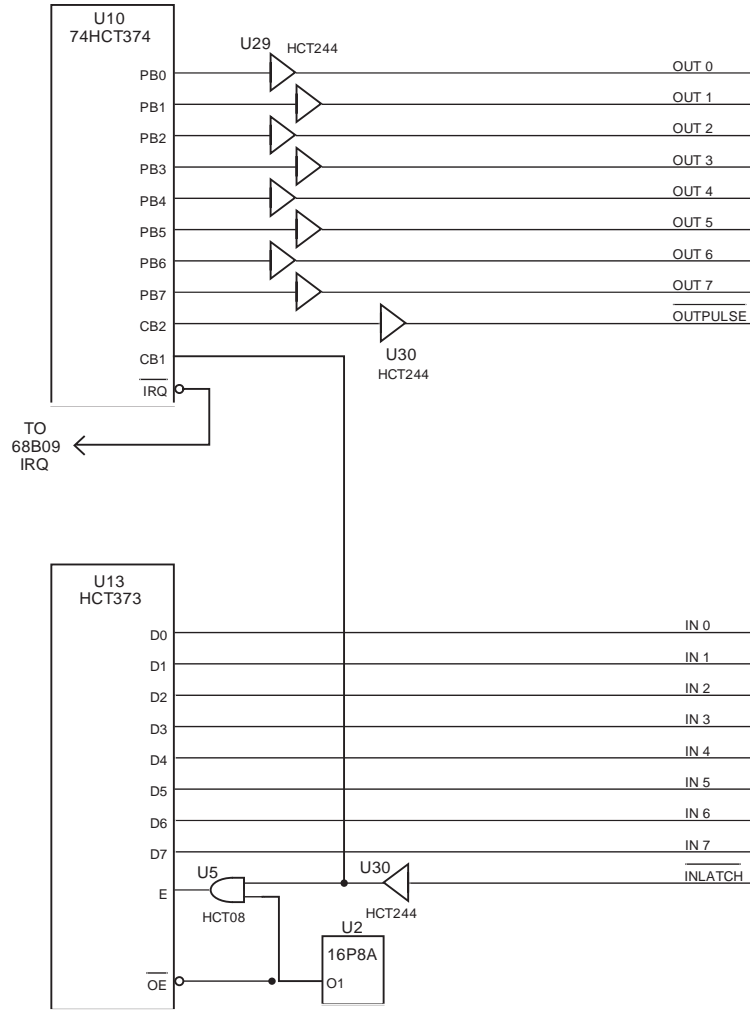
The GPIA simplifies microprocessor interfacing to the IEEE-488 bus because many control sequences take place automatically. For example, when the microprocessor writes to the GPIA data output register, the handshake sequence is performed automatically. Without the GPIA chip, complex microprocessor routines would be required.

On the microprocessor side of the GPIA, data transmission is handled much like any other data bus transaction. Microprocessor data access is performed through the D0-D7 lines, while A0-A2 (the three least significant address lines) select among the 14 internal registers (seven read, seven write) of the GPIA. Chip selection is performed by the SELECT 9914 line.

The output of the GPIA is in standard IEEE-488 format. All of these lines are active low with approximately zero volts representing a logic one:

- Eight data lines (D1-D8).
- Three handshake lines (DAV, NRFD, NDAC).
- Five management lines (ATN, REN, IFC, SRQ, EOI).

The two IEEE-488 bus drivers, U15 and U16, bring the drive capability of the interface up to the requirements of the IEEE-488 standard, which includes provisions for up to 15 devices on the bus at once. The outputs of the bus drivers are connected to J25, a standard IEEE-488 connector.



**Figure 6-12**  
Digital I/O interface simplified schematic

## **6.10 Power supply**

The major component of the power section is a single output switching power supply. Its 6.2V output is distributed to the backplane board for the relay coils of the switching cards, and to the voltage regulator board. The 5V output of the voltage regulator board is supplied to all logic circuitry, including that on the switching cards, and to the front panel display board.

# 7

## Maintenance

---

### 7.1 Introduction

This section contains information necessary to maintain and troubleshoot the Model 707A Switching Matrix. Handling and cleaning procedures are also included.

#### WARNING

**The servicing procedures in this section are intended only for qualified electronics service personnel. Do not attempt to perform these procedures unless you are qualified to do so. Some of the procedures may expose you to potentially lethal voltages (>30V RMS) that could result in personal injury or death if normal safety precautions are not observed.**

The section is outlined as follows:

- 7.2 Line Voltage Sensing:** Provides a description of setting the instrument operating voltage.
- 7.3 Fuse Replacement:** Gives the procedure for replacing the line fuse located on the rear panel.
- 7.4 Fixed Rack Installation:** Lists the installation instructions for a fixed rack mount kit for a Model 707A.
- 7.5 Disassembly:** Covers the procedure for disassembling the instrument, including circuit board removal.
- 7.6 Backplane Jumpers:** Covers removal and installation of the backplane jumpers.
- 7.7 Battery Replacement:** Outlines the procedure for replacing the lithium battery.
- 7.8 Static-sensitive Devices:** Covers precautions necessary when handling static-sensitive parts within the instrument.

**7.9 Mainframe troubleshooting:** Outlines troubleshooting procedures for the Model 707A.

**7.10 Using an extender card:** Explains usage of an extender card to access switching card circuitry.

**7.11 Cleaning:** Gives the procedure for cleaning the backplane board and the fan filter.

### 7.2 Line voltage sensing

The Model 707A operates from a line voltage in the range of 100 to 240V, at a frequency of 50 or 60Hz. Line voltage and frequency are automatically sensed, therefore there are no switches to set. Check to see that the line power in your area is compatible.

Perform the following steps to connect the power supply to the line power and turn it on:

1. Before plugging in the power cord, make sure the front panel power switch is in the off (0) position.
2. Connect the female end of the supplied power cord to the AC receptacle on the rear panel.

#### WARNING

**The power cord supplied with the Model 707A contains a separate ground use with grounded outlets. When proper connections are made, instrument chassis is connected to power line ground through the ground wire in the power cord. Failure to use a grounded outlet may result in personal injury or death due to electric shock.**

### 7.3 Fuse replacement

The line fuse, located on the rear panel, protects the power line input of the instrument. Use the following procedure to replace the fuse, if necessary.

**WARNING**

**Disconnect the instrument from the power line and other equipment before replacing the fuse.**

1. With the power off, place the end of a flat-bladed screwdriver into the slot in the rear panel fuse holder. Press in gently and rotate the fuse holder approximately one-quarter turn counterclockwise. Release pressure on the holder and allow the internal spring to push the carrier and fuse out of the holder.
2. Separate the fuse from the carrier by carefully pulling the two apart.
3. Using an ohmmeter, check the fuse for continuity. A good fuse will show low resistance, while a blown fuse will read high (essentially infinite) resistance.
4. If the old fuse is defective, replace it with the type recommended in Table 7-1.

**CAUTION**

**Do not use a fuse with a higher rating than specified, or instrument damage may occur. If the instrument repeatedly blows fuses, locate and correct the cause of the problem before resuming operation of the unit.**

5. Install the new fuse, located in the fuse carrier, by reversing the above procedure.

**Table 7-1**  
*Line fuse values*

Line Voltage Range	Fuse Rating	Keithley Part No.
100 to 240 VAC	5A, 250V, slow blow, 3AG	FU-64

### 7.4 Fixed rack installation

Table 7-2 lists the necessary hardware for a fixed mounting of a Model 707A in a 19" wide rack (24 to 30" deep). Verify that all parts are available before beginning the installation procedure.

**Table 7-2**  
*Fixed rack parts*

Item	Description	Keithley Part No.	Qty.
A	Chassis Support (left)	707-321	1
B	Chassis Support (right)	707-322	1
C	Nut, #10-32 Captive	FA-148	4
	Bracket Kit consisting of:	BR-31	1
D	Rear Support Bracket	—	2
E	Spacer Bar	—	2
F	Nut Bar	—	4
G	Screw, #10-32 × 1/2" Phil. Binder Hd.	—	12

#### Rack preparation

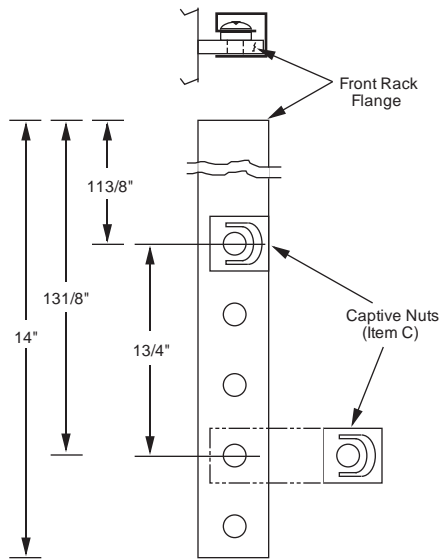
1. Select a position in the rack. In most cases, the weight of the Model 707A dictates a position in the lower half of the rack. The Model 707A will take up 14" of vertical space.

**NOTE**

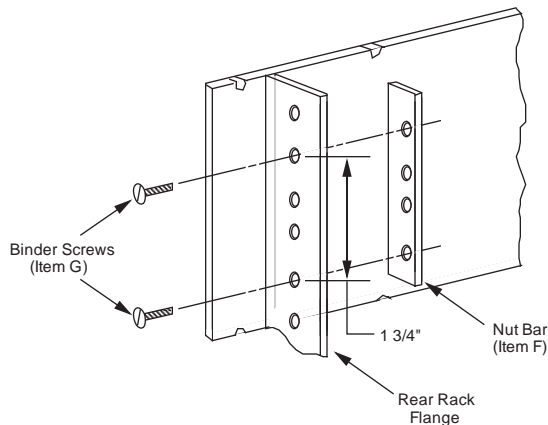
The mainframe must be mounted at a height that is an increment of 1-3/4" from the top or bottom of the rack. Attempting to mount the mainframe at a non-incremental height will lead to difficulties with hole alignment.

2. Referring to Figure 7-1, install two captive nuts (item C) on each front rack flange at holes 11-3/8" and 13-1/8" from the top of the selected space.
3. Loosely attach a nut bar (item F) to each rear rack flange with two binder head screws (item G). See Figure 7-2. Mount the nut bars with the outer holes at the same level as the captive nuts. Note that the hole pattern on the nut bar is not symmetrical.





**Figure 7-1**  
Captive nut installation



**Figure 7-2**  
Nut bar on flange

### Chassis support preparation

4. Place a rear support bracket (item D) on the left chassis support (item A) and temporarily install the two pieces in the rack by sliding them apart until their flanged ends fit as shown in Figure 7-3. Note which holes will be used to attach the two pieces together.
5. Use a spacer bar, nut bar, and two binder head screws (items E, F, and G) to loosely attach each rear support bracket to a chassis support. Figure 7-4 shows the left side support.

### Chassis support mounting

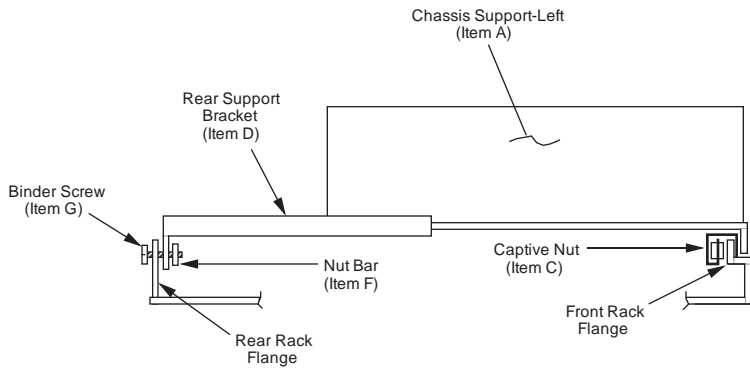
6. Reinstall the chassis support assemblies in the rack and secure them to the captive nuts with binder head screws. Also tighten the binder screws at the rear rack flange.
7. Tighten the screws attaching the two pieces of the chassis support assemblies.

### Mainframe installation

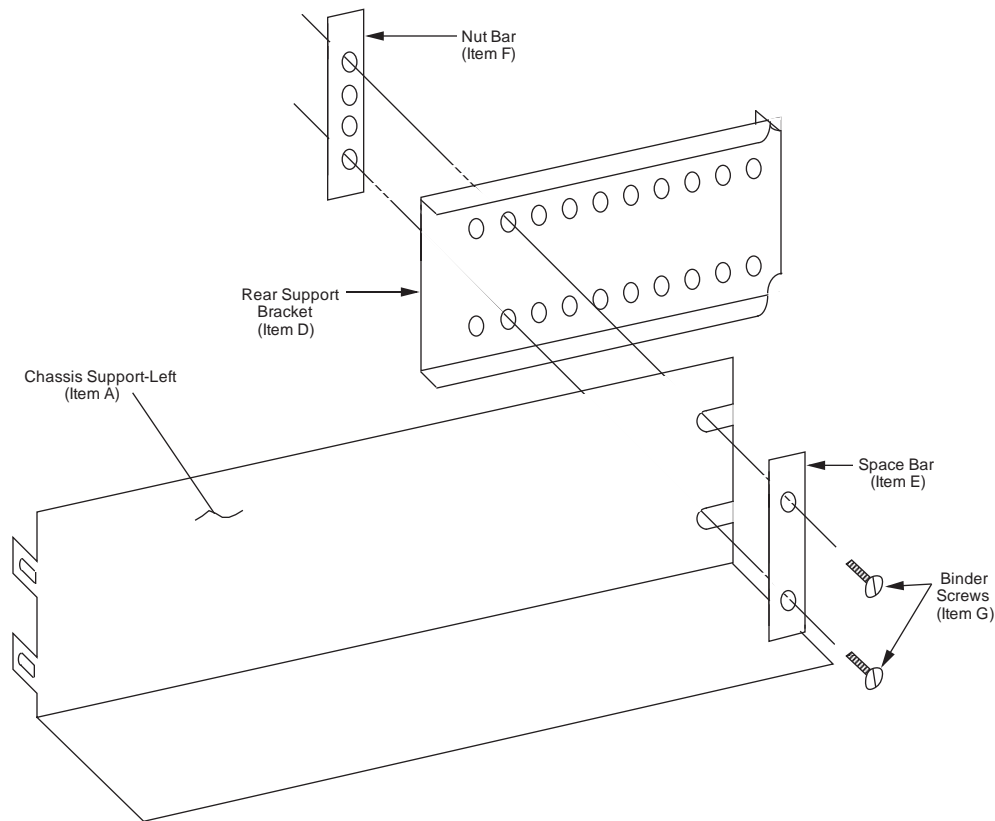
8. Lift the Model 707A mainframe onto the chassis supports and slide it into the rack.
9. The mainframe can be secured to the front rack flanges with user-supplied captive nuts and binder head screws (four each).

### NOTE

The chassis supports hold the Model 707A in place while you are mounting the mainframe to the front rack flanges. Once the Model 707A is secured, there may be a gap between the mainframe and the chassis supports.



**Figure 7-3**  
Chassis support sizing



**Figure 7-4**  
Chassis support assembly

## 7.5 Disassembly

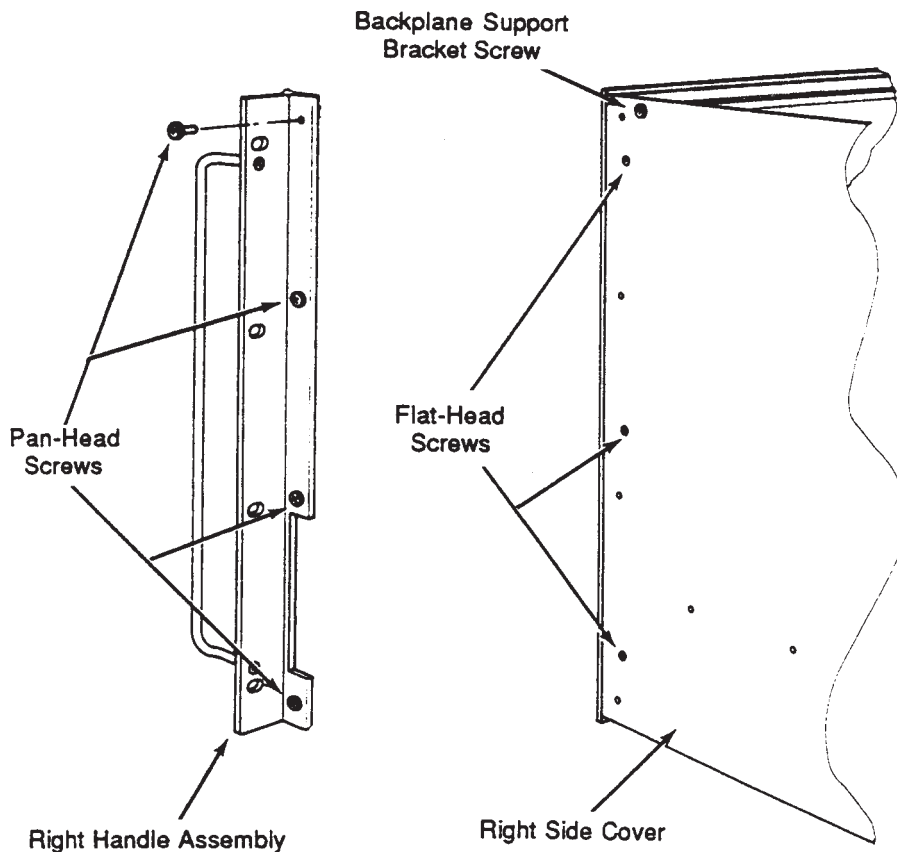
If it is necessary to troubleshoot the instrument or replace a component, use the following disassembly procedure. In addition to the figures, use the assembly drawings at the end of this section to assist you as you disassemble and re-assemble the Model 707A.

- Rear panel assembly — 707A-030
- Rear panel wiring — 707A-031
- Front panel assembly — 707A-040
- Chassis assembly/wiring — 707A-050
- Final chassis wiring assembly — 707A-051
- Final inspection — 707A-080

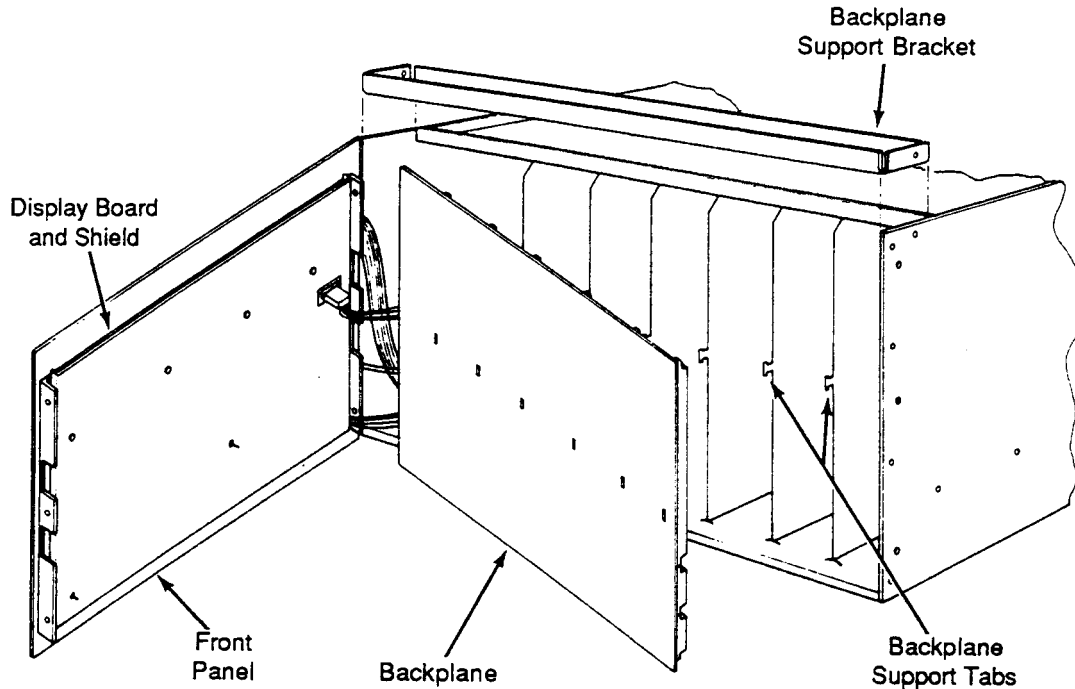
### WARNING

**Before disassembly, disconnect the line cord, ensure no voltage is applied from user circuits, and remove all plug-in cards from the instrument.**

1. With the Model 707A on a bench, remove the front panel as follows:
  - A. Place a thin book or other support under the unit to slightly raise the bottom edge of the front panel off the bench surface.
  - B. Remove the four pan-head screws that secure the right and left handle mounting brackets to the side covers. Figure 7-5 shows a view of the right side.
  - C. Remove the three flat-head screws securing each side of the front panel to the right and left side covers.
  - D. Gently pull the front panel away from the main-frame. It may be necessary to loosen the two pan-head screws holding the backplane support bracket.
  - E. Swing the front panel to the left and rest it on its edge as shown in Figure 7-6.



**Figure 7-5**  
Right side view of disassembly



**Figure 7-6**  
Front view of disassembly

2. As shown in the assembly drawings, remove the left side cover:
  - A. Remove the ten pan-head screws securing the left side cover, including the one previously loosened in step 1D.
  - B. Pull the side cover off its support tabs.
3. Remove the display board as follows:
  - A. Unplug the following connections:
    - P32 — Digital board connection to light pen connector on front panel.
    - P34 — Digital board ribbon cable connection to display board.
    - P36 — Display board connection to voltage regulator board.
  - B. Disconnect the plug between the power switch on the front panel and the terminal strip in front of the digital board.
  - C. Remove the four screws securing the display board shield and display board to the front panel.
4. Remove the backplane board as follows:

**CAUTION**

**Avoid touching the board surface. Contamination can result in degraded matrix card performance. If contamination occurs, clean the board as described in paragraph 7.11.**

- A. Remove the backplane support bracket shown in Figure 7-6.

- B. Unplug the following connections:
    - P33 — Digital board ribbon cable connection to backplane board.
    - P33 — Backplane board connection to power supply.
  - C. Remove the grounding wires from the grounding stud on the rear panel.
  - D. Lift the backplane board by its edges off the backplane support tabs.
5. Referring to the assembly drawings, remove the digital board as follows:
    - A. On the Model 707A rear panel, pull off the Relay Test connector (P24). Also unscrew the two black standoffs from the IEEE-488 connector (J25).
    - B. On the digital board, disconnect the following plugs (if not previously removed):
      - P29 — Connector to External Trigger and Matrix Ready jacks.
      - P30 — Ribbon cable connector to Digital I/O port.
      - P31 — Connector to power supply.
      - P32 — Connector to light pen connector on front panel.
      - P33 — Ribbon cable connector to backplane board.
      - P34 — Ribbon cable connector to display board.
    - C. Remove the five screws securing the digital board to the mainframe and lift out the board.
  6. Reverse the above procedure to re-assemble the instrument.

## 7.6 Backplane jumpers

The Model 707A backplane has jumpered connections between slots 3 and 4 for the following general purpose signals:

- HI and LO of analog bus #1 (e.g., rows C-F of Model 7072).
- HI, LO, and Guard of analog bus #2 (e.g., rows A-H of Model 7071).

These jumpers can be removed to selectively isolate the signals of slots 1-3 from slots 4-6. If all jumpers are removed, there will be two 3-slot general purpose analog backplanes in one mainframe. An example system configuration using this isolation method is described in Section 3.

The following steps outline the procedure for removing backplane jumpers. Also refer to Figures 7-5 through 7-7.

### WARNING

**Turn off mainframe power and disconnect the line cord. Ensure no voltage is applied from user circuits, then remove all cards.**

1. Set the mainframe on a bench. (Slightly raise the bottom edge of the front panel off the bench surface by placing a thin book under the mainframe.) Remove the eight pan-head screws holding the handles to the unit.
2. Remove the six flat-head screws attaching the front panel.
3. Grasping the right side of the front panel, swing it to the left approximately 45° and rest it on its edge.

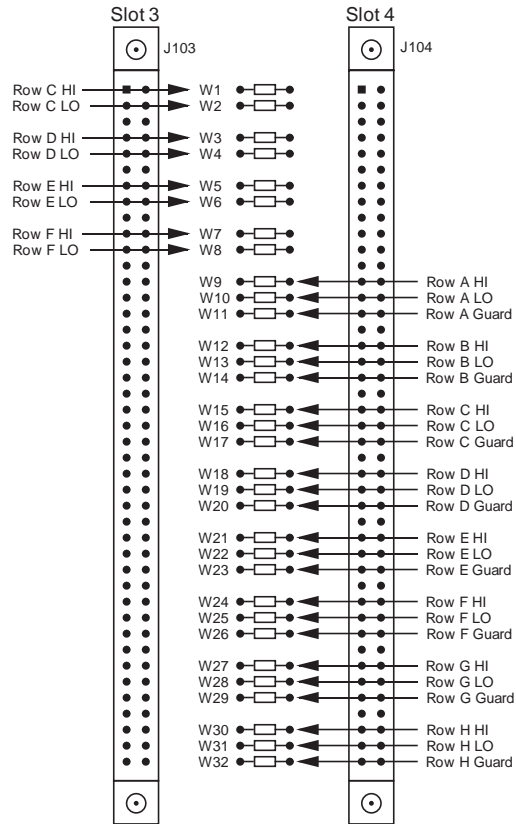
### CAUTION

**Do not touch the surface of the backplane to prevent possible contamination from body oil and dirt, which could degrade insulation resistance.**

4. The backplane jumpers are called out in Figure 7-7. Remove them by snipping with diagonal cutters.

If it is necessary to clean the connector side of the backplane or re-insert backplane jumpers (Keithley part number J-15) continue with these steps:

5. Remove the two pan-head screws attaching the backplane support bracket, and remove the bracket.
6. Handle the board by the edges only. Do not touch any board surfaces. When servicing, wear clean, white cotton gloves.
7. If making solder repairs on the board, use a flux that is rosin RMA based. Remove the flux from these areas when the repair is complete. Use methanol and clean cotton swabs to remove the flux. Take care not to spread the flux to other areas of the board.
8. Once the flux has been removed, swab only the repaired area with methanol, and then blow-dry the board with dry nitrogen gas.
9. After cleaning, the board should be placed in a 50°C low humidity environment for several hours.
10. Reassemble the unit taking care to align the backplane with its supports before attaching the front panel and handles.



**Figure 7-7**  
Backplane jumpers

## 7.7 Battery replacement

When line power to the Model 707A is turned off, the lithium battery on the digital board provides backup power to the memory in which setups and parameters are stored. The battery has enough capacity to maintain data for one year of continuous power off, or two years if the Model 707A is powered on for 12 hours every day. The battery by itself has a shelf life of eight years. Although the Model 707A will operate without a battery, it will not retain any setups or parameters when turned off and will power up in random conditions.

The battery may be replaced with any CR2450 lithium coin cell. It can also be ordered from Keithley Instruments (part number BA-44), as discussed in Section 8 of this manual.

Replacement of the lithium battery is normally a safe procedure as long as these safety precautions are followed.

### WARNING

**The precautions below must be followed to avoid possible personal injury.**

1. Wear safety glasses or goggles when working with lithium batteries.
2. Do not short the battery terminals together.
3. Do not incinerate or otherwise expose to excessive heat ( $>60^{\circ}\text{C}$ ).
4. Keep lithium batteries away from all liquids.
5. Do not recharge lithium batteries.
6. Observe proper polarity when inserting battery into holder.

Replace the battery as follows:

1. Turn off the power and remove the line cord from the Model 707A.
2. Remove the left handle and side panel. (See paragraph 7.5.)
3. The lithium battery is on the digital board. Pry the battery out of its holder using a non-metallic tool.

### WARNING

**Do not use a metal tool to pry out the battery as you could short its terminals.**

4. Install the new battery, taking care to observe proper polarity as stamped on the battery holder.

5. Reinstall the left side panel and handle.
6. Reinstall the power line cord and turn on the Model 707A. It will power up in random conditions, such as make/break and break/make on the same rows.

## 7.8 Static-sensitive devices

CMOS devices are designed to operate at high impedance levels for lower power consumption. As a result, any static charge that builds up on your person or clothing may be sufficient to destroy these devices if they are not handled properly. Use the precautions below when handling static-sensitive devices:

### NOTE

Since the many CMOS devices installed in the Model 707A are not denoted in this manual, all ICs and transistors should be handled as static-sensitive devices.

1. Transport such devices only in containers designed to prevent static build-up. Typically, these parts will be received in anti-static containers of plastic or foam. Always leave the devices in question in their original containers until ready for installation.
2. Remove the devices from their protective containers only at a properly grounded work station. Also ground yourself with a suitable wrist strap.
3. Handle the devices only by the body; do not touch the pins or terminals.
4. Any printed circuit board into which the device is to be inserted must also be properly grounded to the bench or table.
5. Use only anti-static type de-soldering tools.
6. Use only soldering irons with properly grounded tips.
7. Once the device is installed on the PC board, it is usually adequately protected, and normal handling can resume.

## 7.9 Mainframe troubleshooting

This troubleshooting information is intended for qualified personnel having a basic understanding of digital and analog circuitry. The individual should also be experienced at using common test equipment, as well as ordinary troubleshooting procedures. The information has been written to assist in isolating a defective circuit or circuit section. Isolation of the specific component is left to the technician.

Note that component layout drawings are located at the end of Section 8. Also, refer to Section 6 for an overview of operating principles.

### 7.9.1 Recommended test equipment

Success in troubleshooting equipment like the Model 707A depends not only on the skill of the technician, but also on the use of accurate, reliable test equipment. Table 7-3 lists the minimum recommended equipment for troubleshooting. Other equipment, such as logic analyzers, could also be helpful.

**Table 7-3**  
*Recommended troubleshooting equipment*

Description	Application
DMM (Keithley 2000)	Measure dc voltage.
Dual-trace, triggered sweep oscilloscope, dc to 50MHz	Check clock and logic pulses.

### 7.9.2 Power-up self-test

As described in Section 4, the Model 707A performs a series of tests on power-up. Individual tests in this series that can be used for troubleshooting a Model 707A include:

- ROM test - A checksum test of ROM. Test failure is indicated by a ROM FAIL error message.
- RAM test - A read/write test of battery backed-up CMOS RAM. Test failure is indicated by a RAM FAIL error message.
- Display test - A visual test of the front panel displays.
- Check for all LEDs and indicators being lit.

**Table 7-4**  
*Power supply checks*

Step	Item/component	Signal	Comments
1	PS1	6.2VDC $\pm$ 2% (0.12V)	Measure relay coil voltage at power supply.
2	Voltage Regulator PCB	5VDC $\pm$ 1% (0.05V)	Measure logic voltage and front panel display voltage at voltage regulator board TP103 referenced to TP101.

These three tests can also be performed from the front panel through a menu selection (SELF TEST) or over the IEEE-488 bus with the command J0 (Perform Self-test).

### 7.9.3 Power supply checks

Power supply voltages should be checked first to make sure they are within the required limits. If the various operating voltages are not within the limits, troubleshooting the remaining circuitry can be quite difficult.

Table 7-4 outlines the voltages that should be checked. In addition to the usual checks with a voltmeter, it is a good idea to check the supplies with an oscilloscope to make sure that no noise or ringing is present.

### 7.9.4 Digital board checks

Tables 7-5 through 7-8 list the procedures to check circuitry on the digital board, including the microcomputer, relay control circuitry, display interface, and digital I/O port.

Procedures for testing the light pen and master/slave interface options are listed in Tables 7-9 and 7-10.

The waveforms described in the troubleshooting tables are present with power-up default conditions (idle state), unless otherwise indicated. To view some of the waveforms, it will be helpful to run a program loop. Refer to the programs of Figure 7-10 when directed by the procedure.

**NOTE**

If the ROM (U7) must be replaced for any reason, restore the Model 707A to factory default conditions with a menu selection (FACTORY INIT) or the device-dependent command R0.



**Table 7-5**  
Microcomputer checks

Step	Item/component	Signal	Comments
			The following digital board signals are referenced to digital common.
1	U6 pin 37	MPU Reset	Stays low (110-260msec on power-up), then goes high.
2	U6 pin 34	E clock	1.79MHz square wave for peripheral chips.
3	U9 pin 23	SELECT VIA	Low going pulses (1kHz).
4	U6 pins 8-23	Address bus (A0-A15)	Check for stuck bit.
5	U6 pins 24-31	Data bus (D0-D7)	Check for stuck bit.

**Table 7-6**  
Relay control checks

Step	Item/component	Signal	Comments
			The following digital board signals are referenced to digital common.
1	U9 pin 23	SELECT VIA	See Figure 7-9 for waveforms of steps 8 through 10. Low going pulses (1kHz).
2	U28 pin 5	CLRADDR	High logic pulse at start of each matrix card ID byte transfer sequence on power-up.
3	U28 pin 3	NEXTADDR	Low logic pulse before each byte transfer from matrix card on power-up.
4	U28 pin 6	IDDATA	Matrix card ID logic pulse train on power-up.
5	U12 pin 11	SELECT CARSEL	Pair of low going pulse trains when program #1 is running.
6	U12 pin 16	STROBE	High logic pulse to strobe relay drivers on matrix card.
7	U12 pins 2,5,6,9,12,15	CARD(1-6)	Low logic pulse selects matrix card for data transfer sequence.
8	U24 pin 1	SELECT RELAYDATA	Low going pulse when program #1 is running.
9	U28 pin 7	CLK	Eight low-going pulses (1.79MHz square wave) after each SELECT RELAYDATA pulse.
10	U28 pin 18	RELAYDATA	Logic pulses to load relay drivers on matrix card.

**Table 7-7***Display interface checks*

Step	Item/component	Signal	Comments
			The following digital board signals are referenced to digital common.
1	U9 pin 23	SELECT VIA	See Figure 7-10 for waveforms of steps 2 through 6.
2	U9 pin 18	FPCLK	Low going pulses (1kHz). Base frequency of 895kHz with ten sets of pulses every 1msec.
3	U18 pin 6	DISPCLK	Base frequency of 895kHz with nine sets of pulses every line-sec.
4	U18 pin 3	KEYCLK	Base frequency of 895kHz with one set of pulses every line-sec.
5	U23 pin 6	DISPDATA	See Figure 7-10.
6	U23 pin 2	KEYDATA	See Figure 7-10.

**Table 7-8***Digital I/O checks*

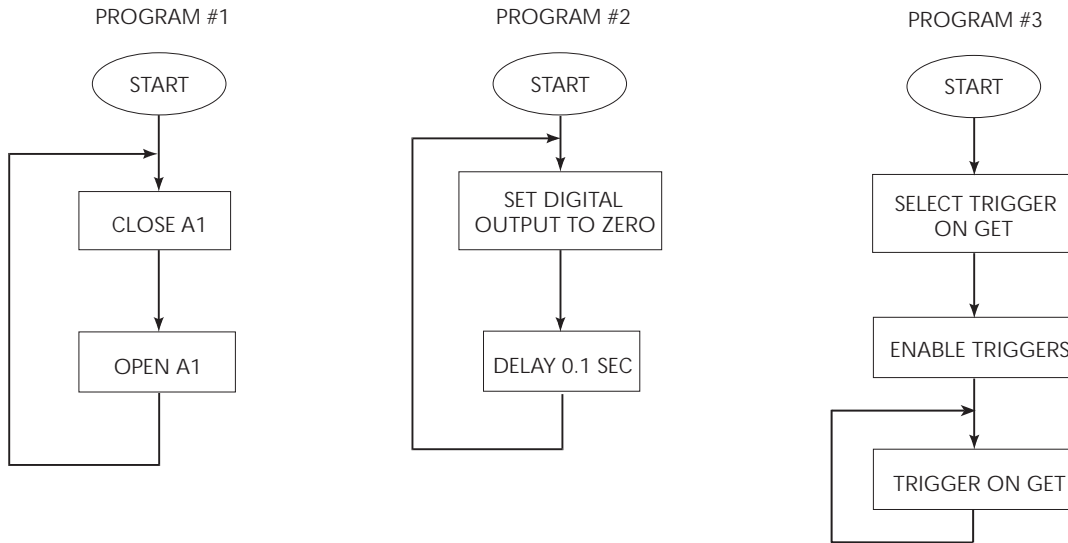
Step	Item/component	Signal	Comments
			The following digital board signals are referenced to digital common.
1	U10 pin 23	SELECT PIA	Low going pulses (1kHz).
2	U10 pins 10-17	OUT(0-7)	Logic low when programmed low.
3	U10 pin 19	OUTPUTPULSE	Low going pulses (600nsec) when program #2 is running.
4	U13 pin 1	SELECT DIG INPUT	Low going pulses (5kHz) when digital input is displayed.
5	U13 pins 3, 4, 7, 8, 13, 14, 17, 18	IN(0-7)	Logic high when port disconnected.

**Table 7-9***Light pen checks*

Step	Item/component	Signal	Comments
			The following digital board signals are referenced to digital common.
1	U9 pin 23	SELECT VIA	Low going pulses (1kHz).
2	U23 pin 12	SENSEPULSE	Low going pulse (15µsec) when light pen is pointed at lit LED.
3	U23 pin 9	LPSWITCH	Low logic level when light pen button is pressed.
4	U9 pin 17	LPSENSE	High going pulse when light pen button is pressed and pen is pointed at an LED.
5	U9 pin 39	LPRESET	Multiple high going pulses when light pen button is pressed.

**Table 7-10***Master/slave checks*

Step	Item/component	Signal	Comments
			The following digital board signals are referenced to digital common.
			When troubleshooting a single unit, loop a cable from Master/Slave Out to Master/Slave In of the same unit, then program unit as master.
1	U11 pins 3,4	RXCLK, TXCLK	895kHz square wave.
2	U11 pin 9	SELECT ACIA	Low going pulses with manual triggers.
3	U11 pins 2,6	RXDATA, TXDATA	Low going pulse pair with manual trigger.
4	U11 pin 7	FIRQ	Low going pulse with manual trigger.
5	U10 pin 23	SELECT PIA	Low going pulses (1kHz).
6	U10 pin 39	M/S TRIGGER	High going pulses when program #3 is running. (Triggering stops when Relay Step equals 100.)



**Figure 7-8**  
Troubleshooting programs

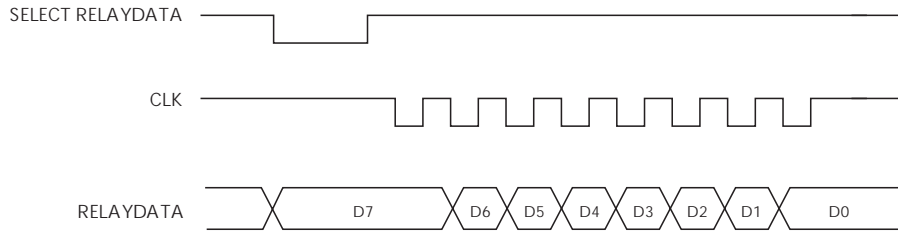
### 7.9.5 Display board checks

To troubleshoot the display board, it is helpful to disassemble it from the front panel, then reconnect the power cable and ribbon cable with the display board on a bench.

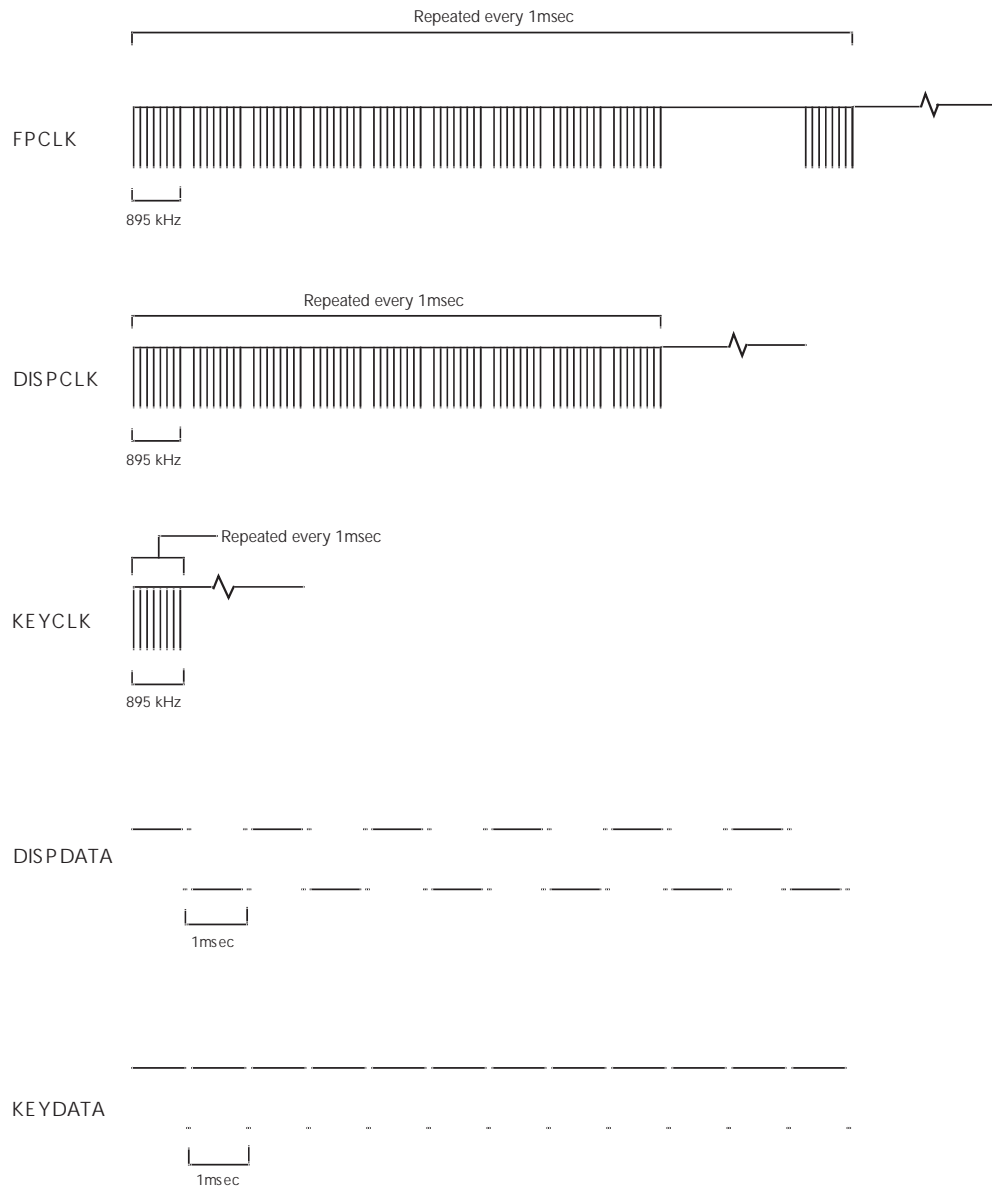
A troubleshooting procedure is outlined in Table 7-11.

**Table 7-11**  
Display board checks

Step	Item/component	Signal	Comments
			The following display board signals are referenced to digital common.
1	U13 pin 12	Source driver	When troubleshooting the LED array, check for these signals when the LED is lit (e.g., crosspoint A1). Card row A - Logic high for 9msec. Card column 1 - Logic low.
2	U3 pin 17	Sink driver	
3	U11 pins 6-12; U12 pins 5-12	Source drivers Sink drivers	Segment displays: Low going pulses (1kHz) with all segments lit.
4	U1 pins 4-7, 14-16; U2 pins 4-7, 14-17		Low going pulses (1kHz).
5	U27 pins 1-6	Button columns	Front panel buttons: Logic high with a low going 1msec pulse. Logic high with a low going 1msec pulse when button pressed.
6	U28 pins 3-5, 11-14	Button rows	



**Figure 7-9**  
Relay control waveforms



**Figure 7-10**  
Display interface waveforms

## 7.10 Using an extender card

To access circuitry on the plug-in relay cards of the Model 707A, use a Model 7070 Universal Adapter Card. The Model 7070 must be configured as an extender card by placing the configuration jumper in the EXTEND position. See the Model 7070 Instruction Manual for complete details on using the card.

## 7.11 Cleaning

### 7.11.1 Backplane

Since card rows are extended on the three analog backplanes of the Model 707A (as explained in Section 3), a contaminated backplane will degrade card isolation specifications. If an isolation problem exists, the backplane should be cleaned only after the isolation of each card has been tested according to the respective card manuals.

The following procedure is primarily intended to clean high impedance PC boards, such as the Model 707A backplane, but it can be used to clean all PC boards. To remove the backplane, refer to paragraph 7.5.

1. Handle the board by the edges only. Do not touch any board surfaces. When servicing, wear clean, white cotton gloves.
2. If making solder repairs on the board, use a flux that is rosin RMA based. Remove the flux from these areas when the repair is complete. Use methanol and clean cotton swabs to remove the flux. Take care not to spread the flux to other areas of the board.
3. Once the flux has been removed, swab only the repaired area with the methanol, then blow-dry the board with dry nitrogen gas.

4. After cleaning, the board should be placed in a 50°C low humidity environment for several hours.

### 7.11.2 Fan filter

The fan filter, which is located on the rear panel, keeps dirt from being drawn into the instrument by the internal cooling fan. The filter opening should be kept free of obstructions to ensure proper instrument cooling.

The filter should be checked periodically for dirt build-up, and cleaned or replaced, as necessary. Use the following procedure to clean or replace the filter.

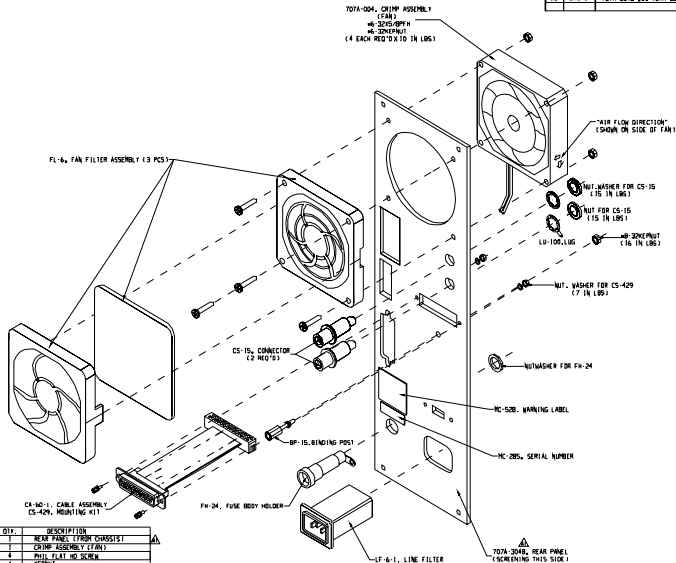
1. Disconnect the line cord from the power line receptacle.
2. Grasp the filter holder, and pull it free of the rear panel.
3. Remove the filter element from the holder.
4. Soak the filter in a solution of warm water and mild detergent until clean. Rinse thoroughly in clean water, and allow the filter to dry completely before installation. If a new filter assembly is required, one may be obtained by ordering Keithley part number FL-6.

#### NOTE

Do not operate the instrument with the filter removed to avoid dirt build-up within the instrument.

5. If necessary, clean the fan guard with a damp cloth.
6. Install the filter element in the holder and snap the holder back onto the fan guard. The two tabs on the holder should be oriented at the right and left sides.

LTR	ECA NO.	REVISION	ENG	DATE
A	21522	Revised	ST	8/5/78
A1	21470	707A-304B Vers 707A-304A		



707A-004, CRIMP ASSEMBLY (FAN)  
 #6-32X5/8PFH  
 #6-32X6PMT  
 (4 EACH REQ'D X 1/4 IN LBS)

FL-6, FAN FILTER ASSEMBLY (3 PCS)

CS-15, CONNECTOR (2 REQ'D)

BP-15, BINDING POST

FH-24, FUSE BODY HOLDER

LF-6-1, LINE FILTER

"AIR FLOW DIRECTION"  
 (SHOWN ON SIDE OF FAN)

NUT, WASHER FOR CS-15  
 (15 IN LBS)

NUT FOR CS-15  
 (15 IN LBS)

#6-32X6PMT  
 (16 IN LBS)

NUT, WASHER FOR CS-429  
 (7 IN LBS)

NUT/WASHER FOR FH-24

MC-508, WARNING LABEL

MC-285, SERIAL NUMBER

707A-304B, REAR PANEL  
 (SCREENING THIS SIDE)

PART No.	QTY.	DESCRIPTION
707A-304B	1	REAR PANEL (FORM CHASSIS)
707A-004	1	CRIMP ASSEMBLY (FAN)
#6-32X5/8PFH	4	PHIL FLAT HD SCREW
#6-32X6PMT	4	REPNUT
FL-6	1	FAN FILTER
CA-60-1	1	CABLE ASSEMBLY
CS-429	1	HARDWARE KIT
BP-15	1	BINDING POST
FH-24	1	FUSE HOLDER BODY
LF-6-1	1	LINE FILTER
#6-32X6PMT	2	REPNUT
CS-15	2	CONNECTOR
LU-100	1	LUG
MC-285	1	SERIAL NO. LABEL
MC-508	1	WARNING LABEL

TITLE	USE D. IN
707A-030C	Rear Panel Wiring
707A-030B	REAR PANEL ASSEMBLY

DO NOT SCALE THIS DRAWING

DIRECTION OF DIMENSIONS  
 UNLESS OTHERWISE SPECIFIED

DATE 1/6/78

SCALE 1/4" = 1"

TITLE REAR PANEL ASSEMBLY

MATERIAL

FINISH

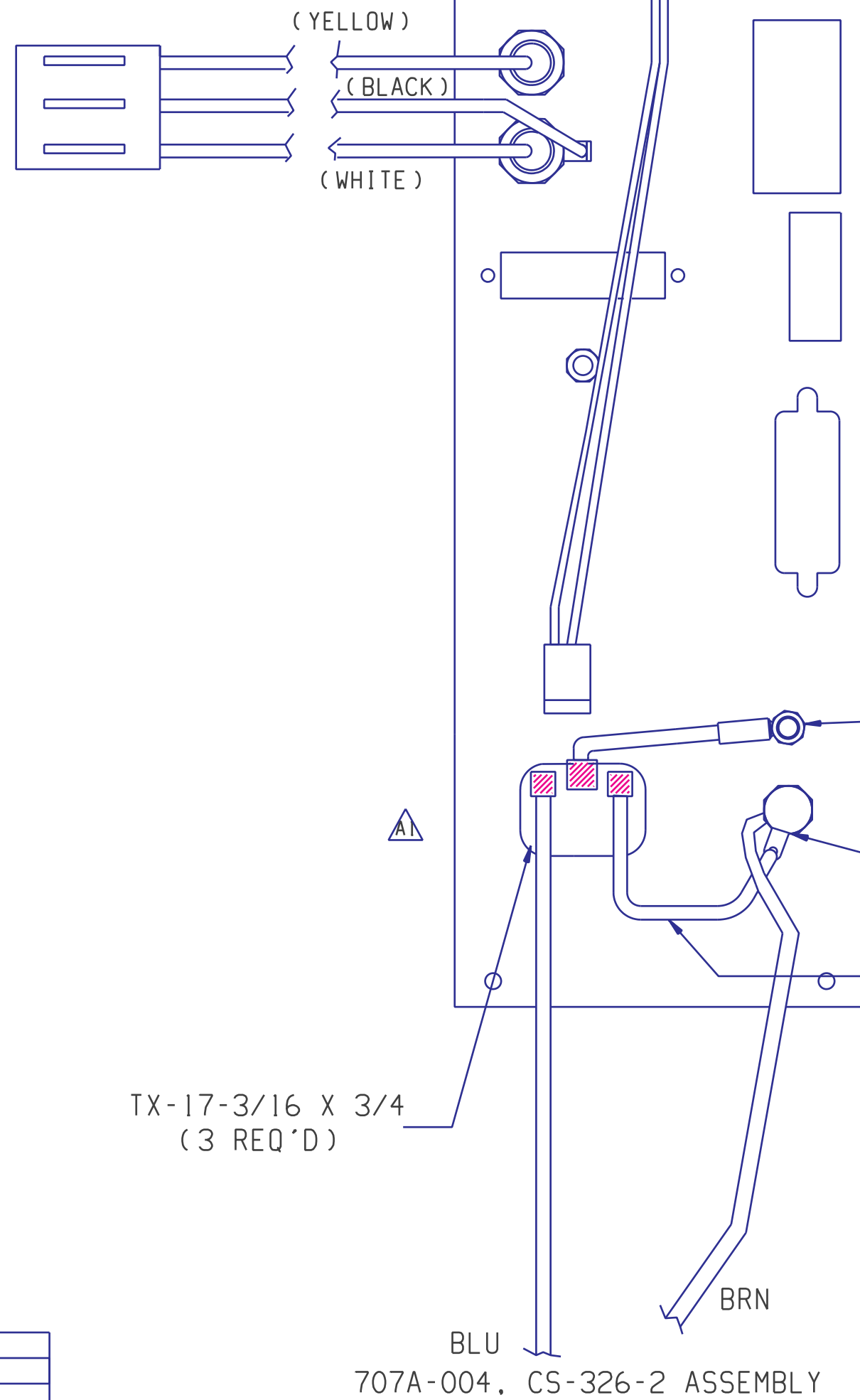
NO. 707A-030

KEYTHLEY Keithley Instruments, Inc.  
 Cleveland, Ohio 44130

LTR	ECA NO.	REVISION	ENG	DATE
A	21522	Released	ST	5/6/98
AI	24240	Updated Line Filter		

707A-030, REAR PANEL ASS'Y  
(REAR VIEW)

707A-004, CS-287-3 ASSEMBLY



INSERT FU-64.(5 AMP. FUSE) AND  
FH-25 ( FUSE HOLDER, CARRIER )  
INTO FH-24 AFTER WIRING IS  
COMPLETED

707A-004  
SC-73 - 4-1/4". GRN/YEL  
#6-32KEPNUT ( 10 IN LBS )

TX-17-1/2 X 1-1/4

707A-002  
SC-72 - 3-1/2". BRN

TX-17-3/16 X 3/4  
( 3 REQ'D )

BLU  
707A-004, CS-326-2 ASSEMBLY

PART No.	QTY	DESCRIPTION
707A-030	1	REAR PANEL ASSEMBLY
707A-002	1	WIRE CUTTING
707A-004	1	WIRE PREP/ASSEMBLY
TX-17-1/2 X 1-1/4"	1	SHRINK TUBING
TX-17-3/16 X 3/4"	3	SHRINK TUBING
FH-25	1	FUSE HOLDER CARRIER
FU-64	1	FUSE, 5 AMP
#6-32KEPNUT	1	KEPNUT

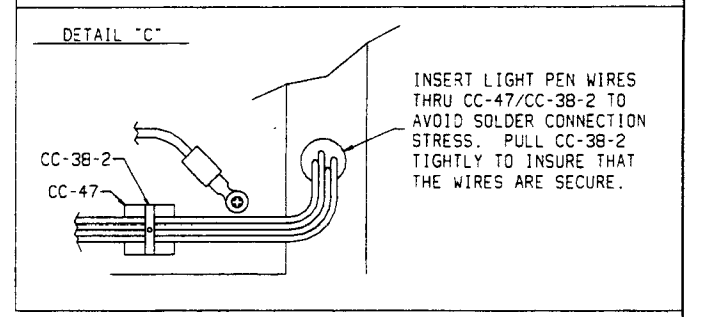
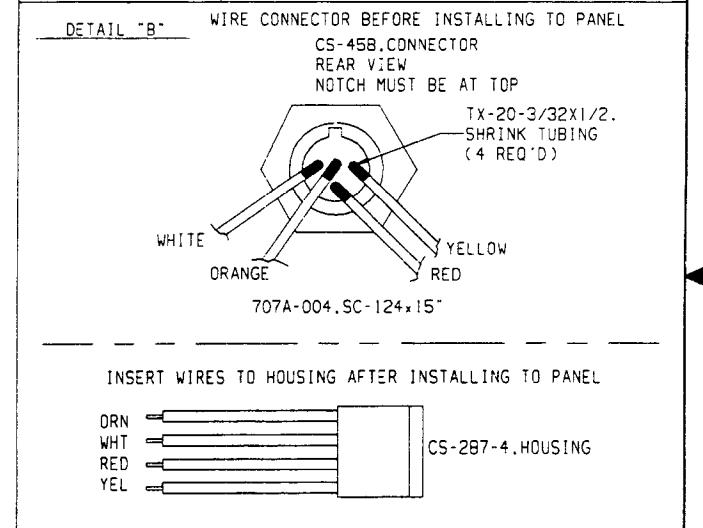
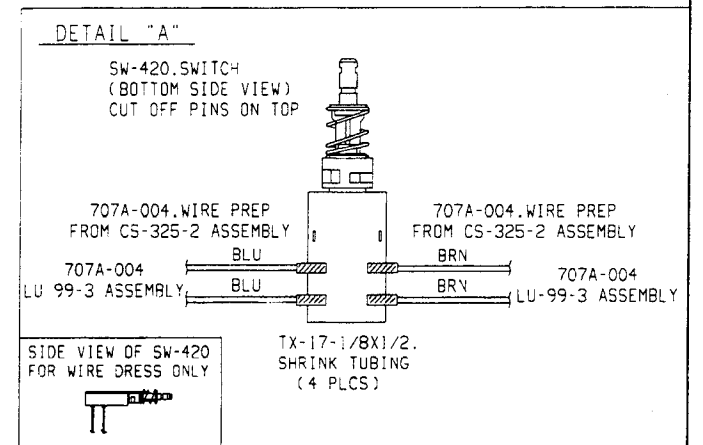
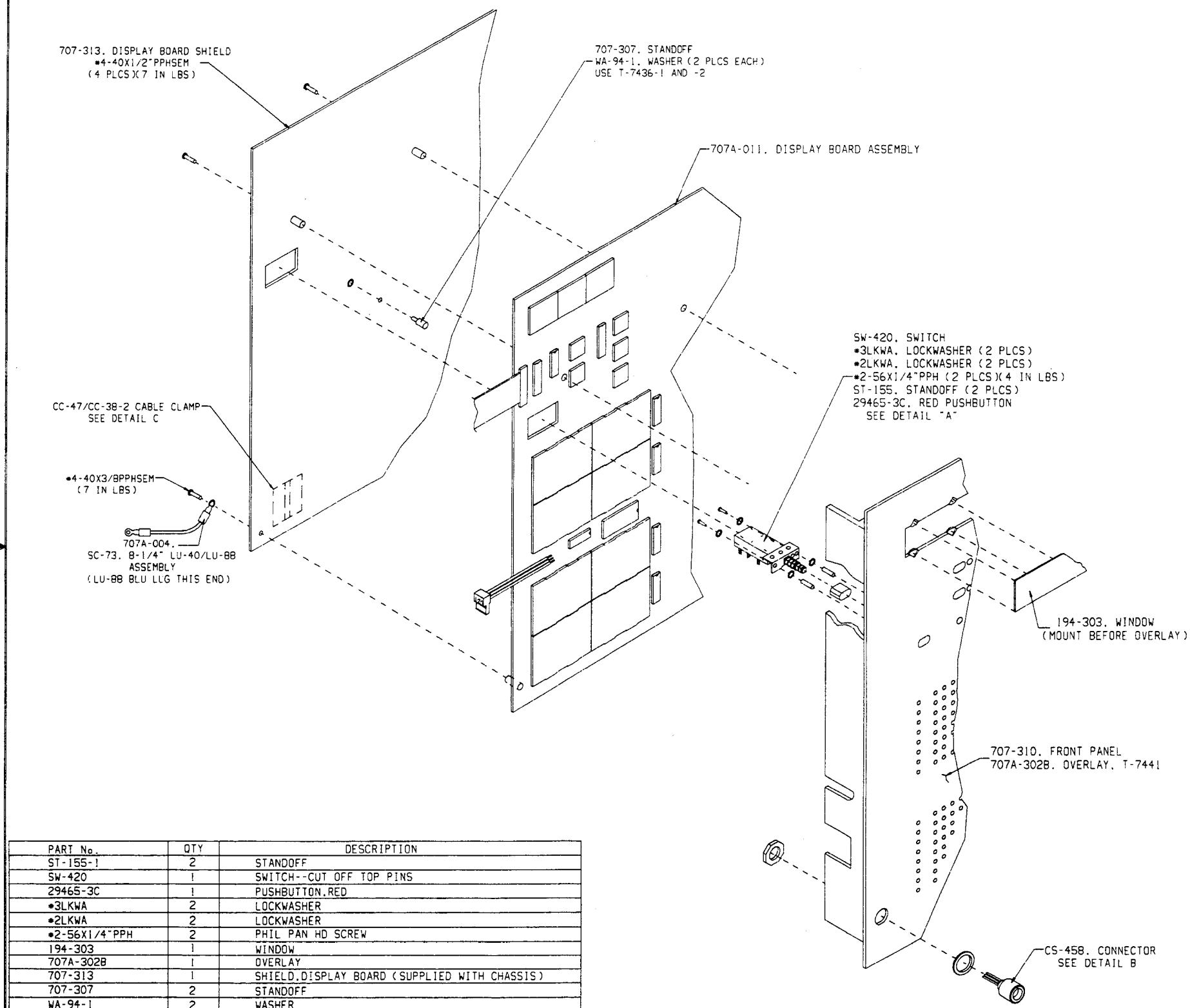
MODEL	NEXT ASSEMBLY	NEXT PROCESS STEP	QTY
707A	707A-050D	CHASSIS ASS'Y/WIRING	1

DO NOT SCALE THIS DRAWING		DIMENSIONAL TOLERANCES UNLESS OTHERWISE SPECIFIED		DATE 11/5/98	SCALE $\times$	TITLE REAR PANEL WIRING	
KEITHLEY Keithley Instruments Inc. Cleveland, Ohio 44139		XX - $\pm .015$	ANG - $\pm 1^\circ$	DRN Mot	ENG APPR	NO. 707A-031	
		XXX - $\pm .005$	FRAC - $\pm 1/64$	MATERIAL	$\times$	C	
		SURFACE MAX $\checkmark$		FINISH	$\times$		



NO. 707A-040

LIT. ECA NO.	REVISION	ENG	DATE
A	2/15/98 Released	ST	5/6/98



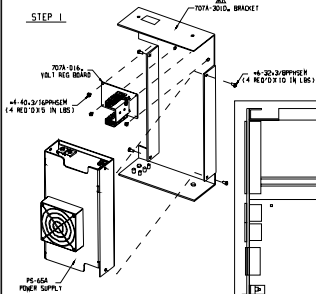
PART No.	QTY	DESCRIPTION
ST-155-1	2	STANDOFF
SW-420	1	SWITCH--CUT OFF TOP PINS
29465-3C	1	PUSHBUTTON, RED
#3LKWA	2	LOCKWASHER
#2LKWA	2	LOCKWASHER
#2-56X1/4" PPH	2	PHIL PAN HD SCREW
194-303	1	WINDOW
707A-302B	1	OVERLAY
707-313	1	SHIELD, DISPLAY BOARD (SUPPLIED WITH CHASSIS)
707-307	2	STANDOFF
WA-94-1	2	WASHER
707A-011	1	DISPLAY BOARD ASSEMBLY
#4-40X1/2" PPHSEM	4	PHIL PAN HD SEM SCREW
CS-45B	1	CONNECTOR
707A-004	1	WIRE PREP/ASS'Y
TX-17-1/8X1/2	4	SHRINK TUBING
TX-20-3/32X1/2	4	SHRINK TUBING
#4-40X3/8" PPHSEM	1	PHIL PAN HD SEM SCREW
707-310	1	FRONT PANEL (SUPPLIED WITH CHASSIS)
CS-287-4	1	HOUSING
CC-47	1	CABLE CLAMP
CC-38-2	1	CABLE CLAMP

DC NOT SCALE THIS DRAWING	DIMENSIONAL TOLERANCES UNLESS OTHERWISE SPECIFIED	DATE 1/5/98	SCALE 2	TITLE								
KEITHLEY Keithley Instruments Inc. Cleveland, Ohio 44139	XX ± .015 ANG ± .1°	DRN Mot	ENG APPR	FRONT PANEL ASSEMBLY								
	XXX ± .005 FRAC ± 1/64	MATERIAL										
	SURFACE MAX 63	FINISH										
<table border="1"> <tr> <td>707A</td> <td>707A-050D</td> <td>CHASSIS ASSEMBLY</td> <td>1</td> </tr> <tr> <td>MODEL</td> <td>NEXT ASSEMBLY</td> <td>NEXT PROCESS STEP</td> <td>QTY</td> </tr> </table>				707A	707A-050D	CHASSIS ASSEMBLY	1	MODEL	NEXT ASSEMBLY	NEXT PROCESS STEP	QTY	USED ON
707A	707A-050D	CHASSIS ASSEMBLY	1									
MODEL	NEXT ASSEMBLY	NEXT PROCESS STEP	QTY									
C				NO. 707A-040								

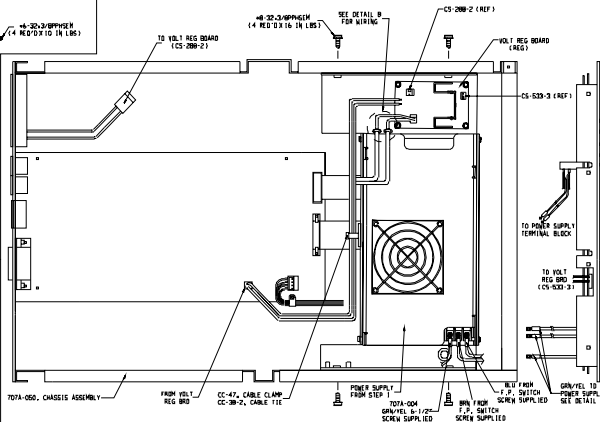


LTR	ECA NO.	REVISION	ENG	DATE
A	21622	Released	ST	5/6/98
AT	22030	707A-0010 Rev. 707A-301C		

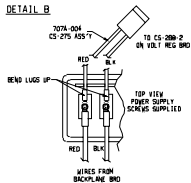
## STEP 1



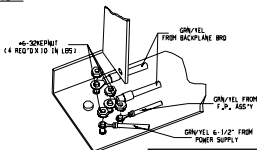
## STEP 2



## DETAIL B



## DETAIL A



PART NUMBER	QTY	DESCRIPTION
707A-004	1	CRIMP ASSY ONLY
707A-016	1	VOLTAGE REG BOARD ASSEMBLY
707A-050	1	CHASSIS ASSEMBLY
707A-301D	1	BRACKET
CC-38-2	1	CABLE TIE
CC-47	1	CABLE CLAMP
PS-65A	1	POWER SUPPLY
46-30-3/4PPH5EM	4	PHIL PAN HEAD SENS SCREW
46-30-3/4PPH5EM	4	PHIL PAN HEAD SENS SCREW
46-30-3/4PPH5EM	4	PHIL PAN HEAD SENS SCREW
46-30EHPMT	4	REPAIR

DO NOT SCALE THIS DRAWING

DIRECTIONAL DIMENSIONS UNLESS OTHERWISE SPECIFIED	DATE 1/12/90	SCALE 1"	TITLE
XX - ±.015 ANG - 11°	DRN Mcl	DRG LLS	FINAL CHASSIS WIRING ASSEMBLY
XXX - ±.005 FRAC - 11/64	MATERIAL		REV. NO.
SURFACE MAX 32	FINISH		707A-051

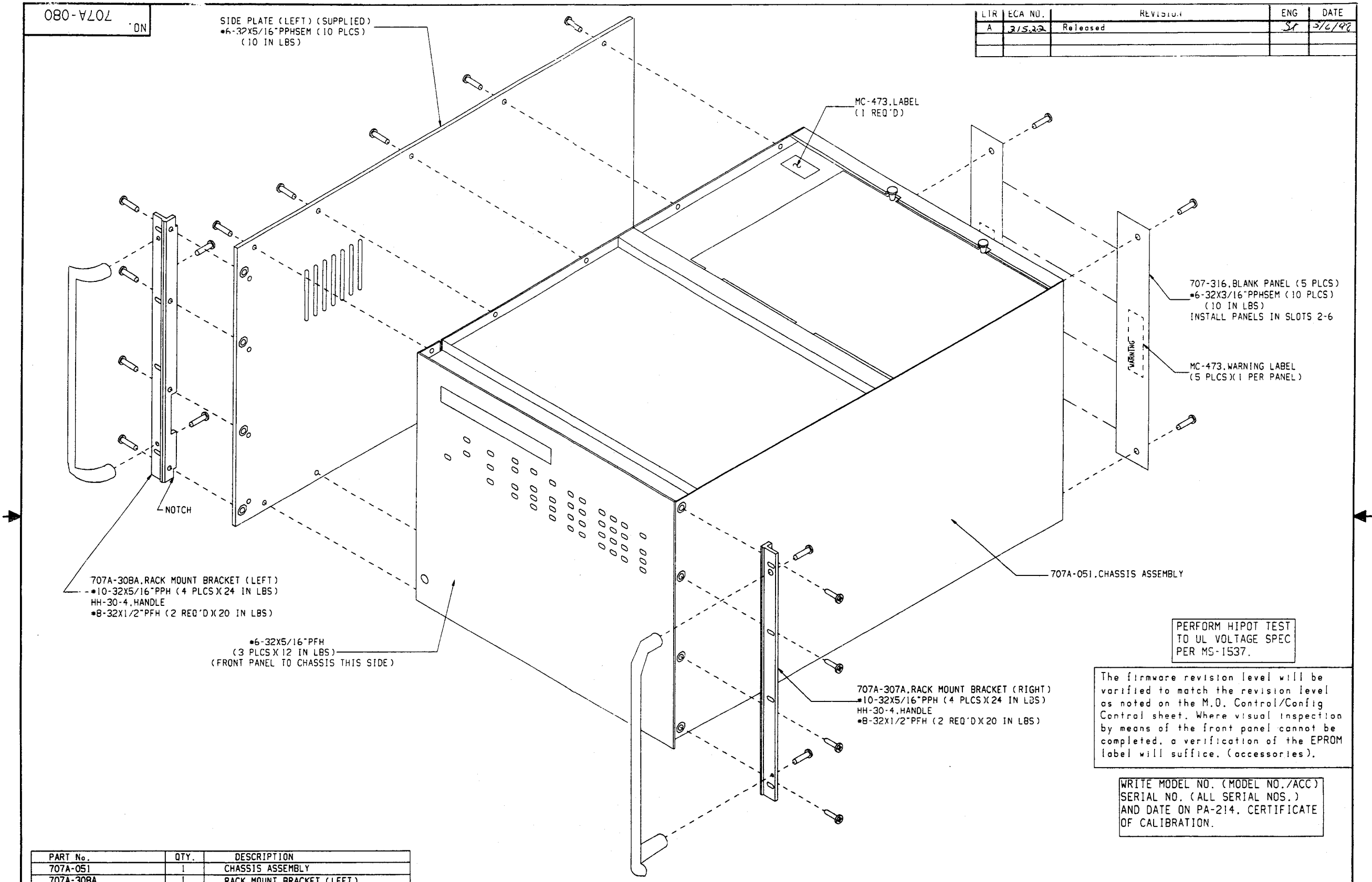
707A	TECH	ISSUED IN
MENEL	NEXT ASSEMBLY	NEXT PROCESS STEP 1 QTY

C

080-4202  
DN

SIDE PLATE (LEFT) (SUPPLIED)  
#6-32X5/16"PPHSEM (10 PLCS)  
(10 IN LBS)

LTR	ECA NO.	REVISION	ENG	DATE
A	2/5/98	Released	ST	3/6/98



707A-308A, RACK MOUNT BRACKET (LEFT)  
#10-32X5/16"PPH (4 PLCS)(24 IN LBS)  
HH-30-4, HANDLE  
#8-32X1/2"PFH (2 REQ'D)(20 IN LBS)

#6-32X5/16"PFH  
(3 PLCS X 12 IN LBS)  
(FRONT PANEL TO CHASSIS THIS SIDE)

MC-473, LABEL  
(1 REQ'D)

707-316, BLANK PANEL (5 PLCS)  
#6-32X3/16"PPHSEM (10 PLCS)  
(10 IN LBS)  
INSTALL PANELS IN SLOTS 2-6

MC-473, WARNING LABEL  
(5 PLCS)(1 PER PANEL)

707A-051, CHASSIS ASSEMBLY

707A-307A, RACK MOUNT BRACKET (RIGHT)  
#10-32X5/16"PPH (4 PLCS)(24 IN LBS)  
HH-30-4, HANDLE  
#8-32X1/2"PFH (2 REQ'D)(20 IN LBS)

PERFORM HIPOT TEST  
TO UL VOLTAGE SPEC  
PER MS-1537.

The firmware revision level will be verified to match the revision level as noted on the M.O. Control/Config Control sheet. Where visual inspection by means of the front panel cannot be completed, a verification of the EPROM label will suffice. (accessories).

WRITE MODEL NO. (MODEL NO./ACC)  
SERIAL NO. (ALL SERIAL NOS.)  
AND DATE ON PA-214, CERTIFICATE  
OF CALIBRATION.

PART No.	QTY.	DESCRIPTION
707A-051	1	CHASSIS ASSEMBLY
707A-308A	1	RACK MOUNT BRACKET (LEFT)
707A-307A	1	RACK MOUNT BRACKET (RIGHT)
HH-30-4	2	HANDLE
#8-32X1/2"PFH	4	PHIL FLAT HD SCREW
#6-32X5/16"PFH	3	PHIL FLAT HD SCREW
#10-32X5/16"PPH	8	PHIL PAN HD SCREW
#6-32X5/16"PPHSEM	10	PHIL PAN HD SEM SCREW
707-316	5	BLANK PANEL
#6-32X3/16"PPHSEM	10	PHIL PAN HD SEM SCREW
MC-473	6	LABEL
PA-214	1	CERTIFICATE OF CALIBRATION

REMOVE CHASSIS ASSEMBLY FROM  
T-7440 (CHASSIS CART FIXTURE)  
THEN ASSEMBLE ALL PARTS

707A	Audit	Audit	1
MODEL	NEXT ASSEMBLY	NEXT PROCESS STEP	QTY
USED ON			

DO NOT SCALE THIS DRAWING		DIMENSIONAL TOLERANCES UNLESS OTHERWISE SPECIFIED		DATE 1/12/98	SCALE 2	TITLE
KATHLEY		XX - ±.015	ANG - ±1°	DRN Mat	ENG APPR	FINAL INSPECTION
Keithley Instruments Inc. Cleveland, Ohio 44139		XXX - ±.005	FRAC - ±1/64	MATERIAL		NO. 707A-080
		SURFACE MAX 63	FINISH			

ORIGINAL IF RED

# 8

## Replaceable Parts

---

### 8.1 Introduction

This section contains replacement parts information and component layout drawings for the Model 707A.

### 8.2 Parts lists

The parts lists for the Model 707A are shown in Tables 8-1 through 8-6.

### 8.3 Ordering information

To place an order or to obtain information concerning replacement parts, contact your Keithley representative or the factory (see front of manual for addresses). When ordering parts, be sure to include the following information:

- Instrument model number (Model 707A)
- Instrument serial number
- Part description
- Component designation (if applicable)
- Keithley part number

To facilitate repairs, complete circuit boards are available. Contact the Repair Department for pricing and availability.

### 8.4 Factory service

If the instrument is to be returned to Keithley Instruments for repair, perform the following:

1. Call the Repair Department at 1-800-552-1115 for a Return Material Authorization (RMA) number.
2. Complete the service form at the back of this manual, and include it with the instrument.
3. Carefully pack the instrument in the original packing carton.
4. Write ATTENTION REPAIR DEPARTMENT and the RMA number on the shipping label.

### 8.5 Component layouts and schematic

The component layouts are provided in the following pages:

Digital board: 707-100

Display board: 707-110

Backplane board: 707A-120

Voltage regulator board: 707A-160

A schematic of the Backplane board (707A-126) is also included.

**Table 8-1**  
Digital board assembly

Circuit designation	Description	Keithley part no.
BT1	BATTERY, LITHIUM-MANGANESE CELL 3V BATTERY HOLDER	BA-44 BH-34
C6	CAP, .01UF, 20%, 50V, CERAMIC	C-365-.01
C31, C32	CAP, 15PF, 10%, 1000V, CERAMIC	C-64-15P
C33-90	CAP, 270PF, 20%, 100V, CERAMIC/FERRITE	C-386-270P
C91	CAP, 3.3UF, 10%, 16V, ALUM ELEC	C-321-3.3
C92	CAP, 10UF, -20+100%, 25V, ALUM ELEC	C-314-10
CR1-17	DIODE, BRIDGE, VM18	RF-52
J22, J23	CONN, 8 PIN CIRCULAR DIN	CS-589
J24	CONN, 6 PIN OPEN END HEADER	CS-587-6
J25	CONN, RIGHT ANGLE, 24 PIN	CS-507
J29	CONN, MALE, 3 PIN	CS-288-3
J30, J33	CONN, MALE HEADER 26-PIN	CS-322-26
J31	CONN, MALE, 2 PIN	CS-288-2
J32	CONN, MALE, 4 PIN	CS-288-4
J34	CONN, HEADER STRAIGHT SOLDER PIN	CS-368-20
K1	RELAY, MINIATURE (DPDT)	RL-98
R39	RES, 10, 10%, 2W, COMPOSITION	R-3-10
U1	INTEGRATED CIRCUIT	IC-573
U2	INTEGRATED CIRCUIT	IC-574
U6	IC, 8 BIT MICROPROCESSING UNIT, MC68B09	LSI-65
U9	IC, VERSATILE INTERFACE ADAPTER, 6522A	LSI-45
U10	IC, PERIPHERAL INTERFACE ADAPTER, 63B21	LSI-61
Y1	CRYSTAL, 7.15909MHZ	CR-24-4

**Table 8-2**

Display board assembly

Circuit designation	Description	Keithley part no.
C16,C17	PUSHBUTTON, BLACK	228-317-8B
DS1, DS2, DS3, DS4, DS5, DS6, DS7	CAP, 270PF, 20%, 100V, CERAMIC/FERRITE	C-386-270P
DS8-31	DIGITAL DISPLAY (DOUBLE DIGIT)	DD-39
DS32, DS33, DS34, DS36, DS37,	DIG DISP (5X7 DOT MATRIX DISP), 2057-AE	DD-44
DS38, DS39, DS40	PILOT LIGHT, RED, LED	PL-71
DS35	PILOT LIGHT, YELLOW, LED	PL-72
FOR PL-71	LED MOUNTS	MK-22-1
FOR PL-72	LED MOUNTS	MK-22-2
P34	CABLE ASSEMBLY, 20 CONDUCTOR	CA-27-8
S1-41	SWITCH, MOMENTARY	SW-435
U13, U14, U15, U16	IC,8-BIT SERIAL-INPUT, UNC5895A	IC-537

**Table 8-3**

Backplane assembly

Circuit designation	Description	Keithley part no.
J19	CABLE ASSEMBLY	CA-27-7
J101, J102, J103, J104, J105, J106	CONNECTOR, CARD EDGE	CS-579-1
J113, J114, J115, J116, J117, J118	CONNECTOR, CARD EDGE	CS-591-1
J107, J108, J109, J110, J111, J112	CONNECTOR, CARD EDGE	CS-591-2
	FASTENER	FA-230-4B
W1-W32	JUMPER	J-15

**Table 8-4**

Voltage regulator assembly

Circuit designation	Description	Keithley part no.
C101	CAP, .1UF, 20%, 50V, CERAMIC	C-365-.1
C102, C103	CAP, 22UF, 20%, 20V TANTALUM	C-179-22
CR101, CR102	DIODE, SILICON, IN4006 (D0-41)	RF-38
	THERMAL TUBE	HS-49-2A
HS101	HEAT SINK	HS-56
J30, J37	CONN, MALE, 2 PIN	CS-288-2
J36	CONN, STRAIGHT POST HEADER, 3-PIN	CS-533-3
U101	INTEGRATED CIRCUIT	IC-1226

**Table 8-5**  
Chassis assembly

<b>Description</b>	<b>Keithley part no.</b>
BRACKET POWER SUPPLY	707A-301B
CABLE CLAMP	CC-37
CABLE CLAMP, NYLON	CC-34
CHASSIS	707A-306A
CONNECTOR, HARDWARE KIT	CS-713
CONNECTOR, PLUG TERMINAL	CS-588-6
REAR PANEL	707A-304
SINGLE OUTPUT SWITCHING POWER SUPPLY	PS-65A

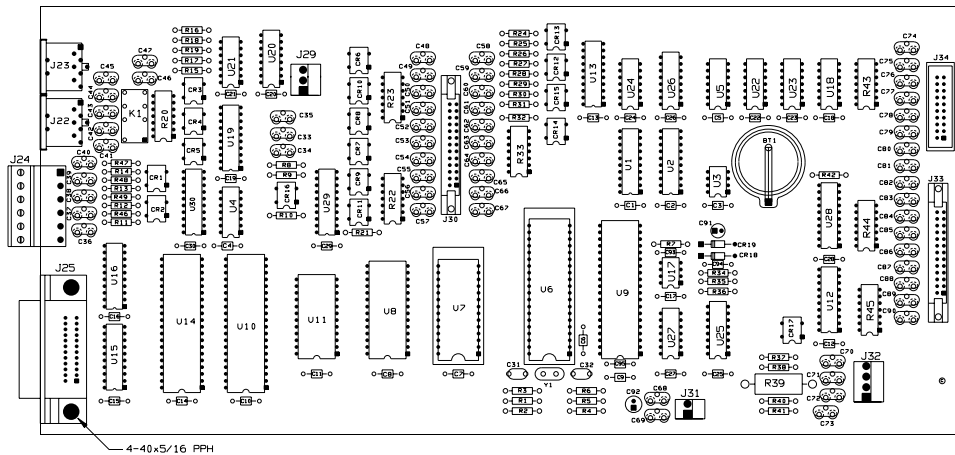
**Table 8-6**  
Miscellaneous

<b>Description</b>	<b>Keithley part no.</b>
BRACKET RACK MOUNT LEFT	707A-308A
BRACKET RACK MOUNT RIGHT	707A-307A
CHASSIS SUPPORT, LEFT	707-322
CHASSIS SUPPORT, RIGHT	707-321
DC FAN	FN-33-3
HANDLE	HH-30-4
LINE CORD	CO-7



001-202.DN

LTR.	ECD NO.	REVISION	ENG.	DATE
A	12185	RELEASED	SZ	6-12-87
B	12434	REVISED	SZ	10-15-87
C	12598	REVISED	SZ	1-28-88
D	12680	REVISED BT1 & ADDED R50	SZ	7-7-88
E	13022	REVISED	SZ	11-4-88
F	14567	ARTWORK WPS REV E. ADDED C94	AJS	6-3-91
G	18092	ARTWORK WPS REV F. ADDED C95	SZ	3-11-90

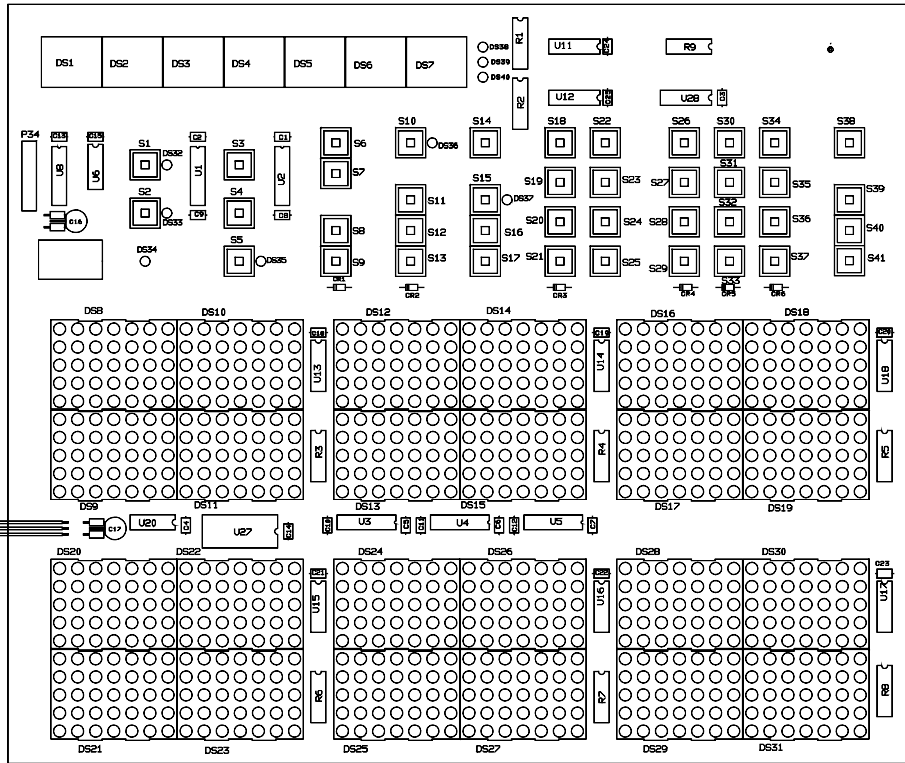


NOTE:  
FOR COMPONENT INFORMATION,  
REFER TO BILL OF MATERIAL  
(707-000-01).

707	NEXT ASSEMBLY QTY
USED ON	

DO NOT SCALE THIS DRAWING	DIMENSIONAL TOLERANCES UNLESS OTHERWISE SPECIFIED	DATE 2-25-87	SCALE 1:1	TITLE
XXX±.015	ANG. ±.2°	DRN. SAZ	ENG. SPPK.	COMPONENT LAYOUT
KEITHLEY KEITHLEY INSTRUMENTS INC CLEVELAND, OHIO 44139	XXX±.005	FRACTIONAL ±.1/64	MATERIAL	NO.
	SURFACE MAX. 63	FINISH		707-100

LTR	ECO NO.	REVISION	ENG	DATE
A	12226	RELEASED	ST	8-24-87
B	12424	REVISED	ST	2-10-88
BI	13108	REVISED	ST	1-24-89



**PUSHBUTTON SELECTION CHART**

SCHEMATIC DESIGNATION	PART NUMBER
S1...S5	C228-317-4
S6...S17	C228-317-5
S18...S27	C228-317-6
S28...S41	C228-317-7

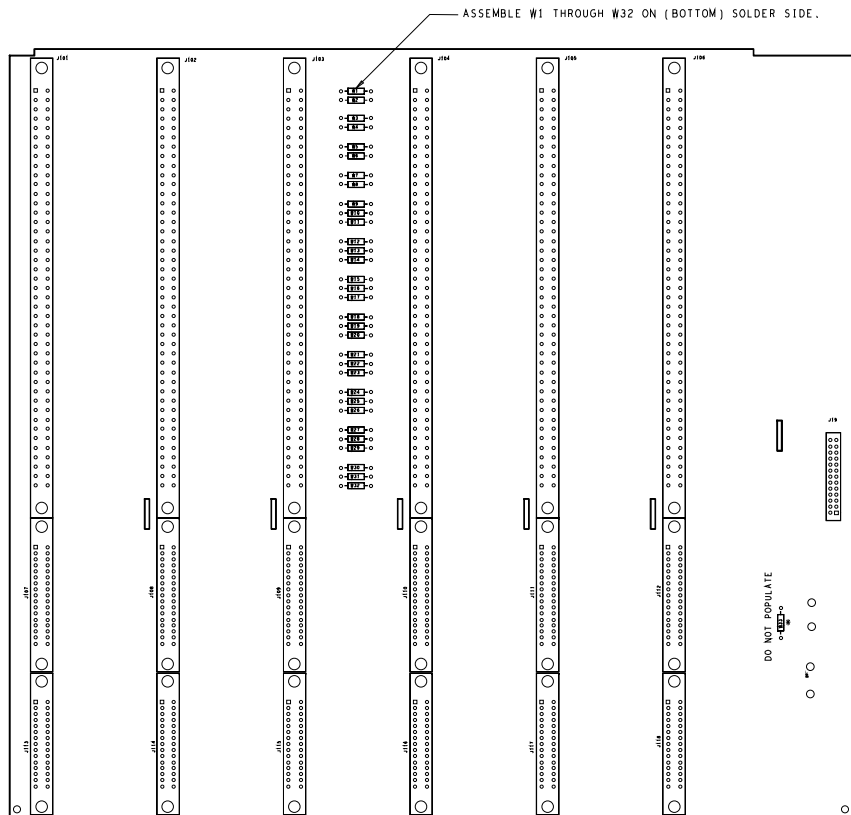
NOTE:  
FOR COMPONENT INFORMATION REFER TO  
BILL OF MATERIAL (707-000-02).

707	707	707
MODEL	NEXT ASSEMBLY	QTY.
	USED ON	

DO NOT SCALE THIS DRAWING	UNLESS OTHERWISE SPECIFIED	DATE 5-22-87	SCALE 1:1	TITLE
XXX1.015	ANG. #1.2	DRN. SAZ	ENG. RLC	COMPONENT LAYOUT, DISPLAY BOARD
XXX2.005	FRAC. #1/64	MATERIAL		D NO. 707-110
	SURFACE MAX. 0.3	FINISH		

707A-120 ON

LTR.	ECA NO.	REVISION	ENG.	DATE
B		RELEASED		



ASSEMBLE W1 THROUGH W32 ON (BOTTOM) SOLDER SIDE.

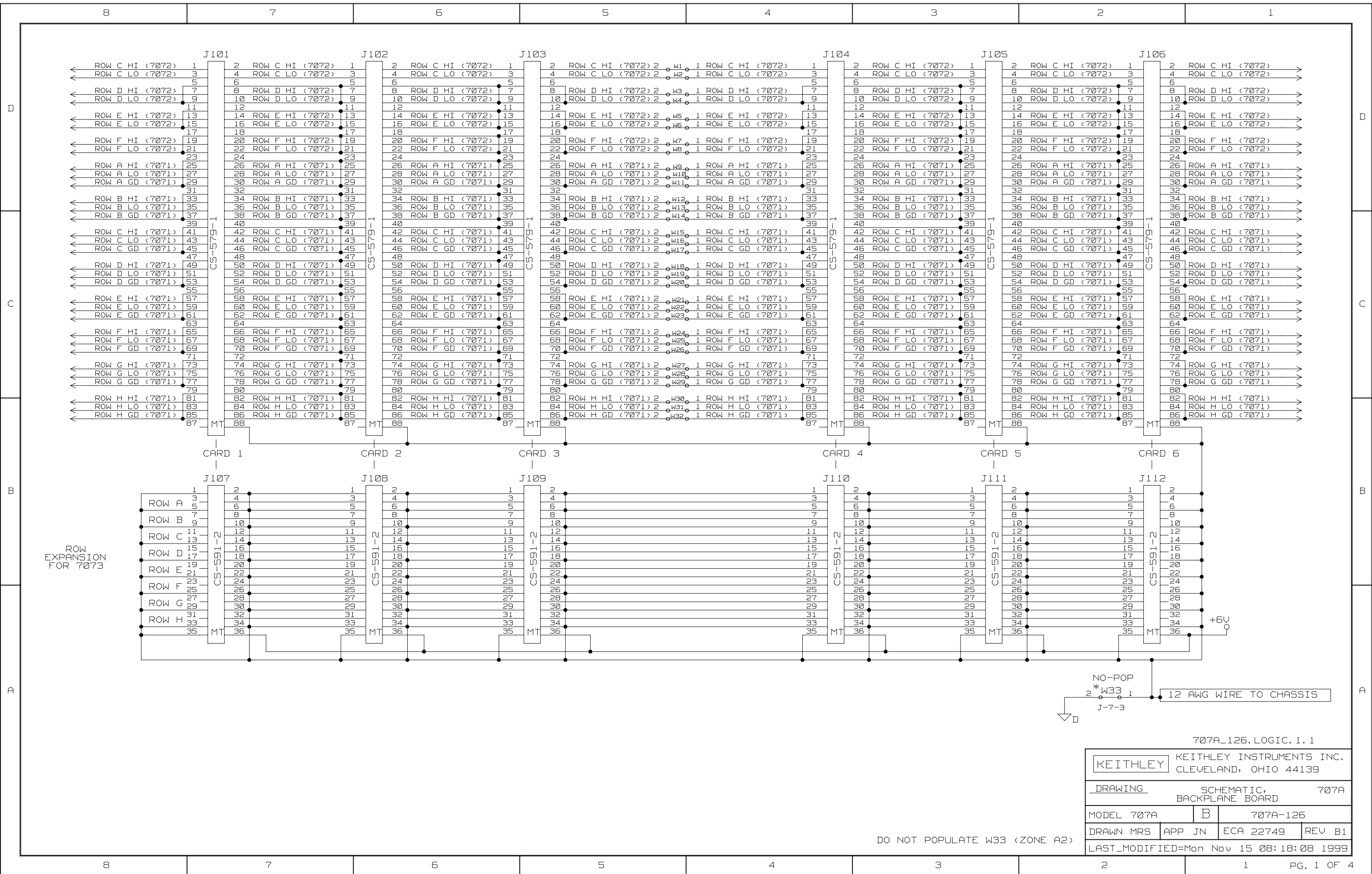
DO NOT POPULATE

FOR COMPONENT INFORMATION SEE PRODUCT STRUCTURE VIEWED FROM COMPONENT (TOP) SIDE.

\* DO NOT POPULATE W33 (ZONE B3)

MODEL	NEXT ASSEMBLY DTY.
	USED ON

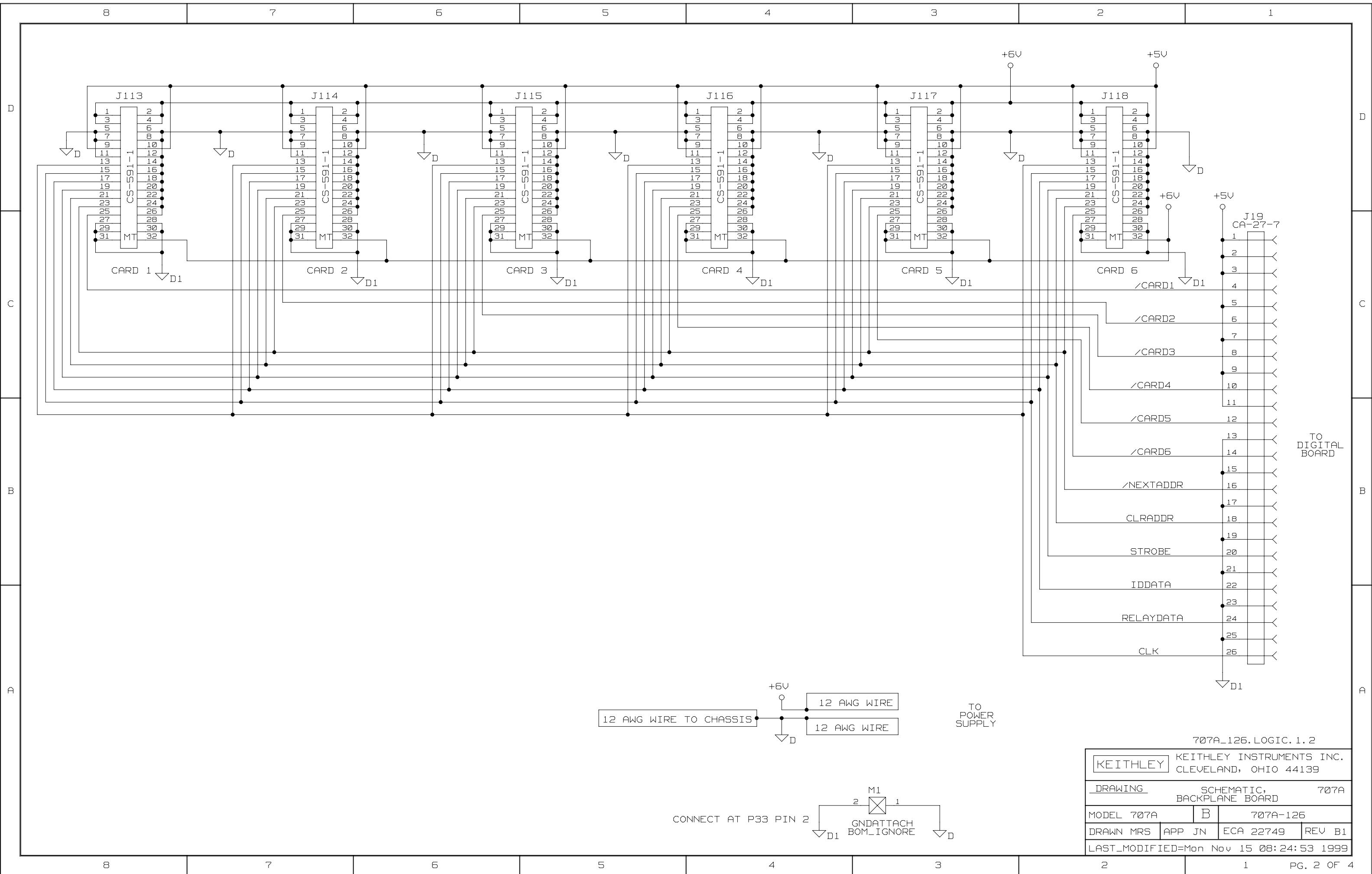
KEITHLEY KEITHLEY INSTRUMENTS INC. CLEVELAND, OHIO 44139	DIM ARE IN IN. UNLESS OTHERWISE NOTED	DATE 4/29/98	SCALE 1:1	TITLE
	DIM. TOL. UNLESS OTHERWISE SPECIFIED XX-.01 XXX-.005	DRN MBS	APPR.	COMPONENT LAYOUT BACKPLANE BOARD
	ANG. TOL. UNLESS OTHERWISE SPECIFIED FRACTIONAL	DO NOT SCALE THIS DRAWING	D No.	707A-120



707A\_126.LOGIC.1.1

KEITHLEY		KEITHLEY INSTRUMENTS INC. CLEVELAND, OHIO 44139	
DRAWING		SCHEMATIC, 707A BACKPLANE BOARD	
MODEL 707A	B	707A-126	
DRAWN MRS	APP JN	ECA 22749	REV B1
LAST_MODIFIED=Mon Nov 15 08:18:08 1999			

DO NOT POPULATE W33 <ZONE A2>



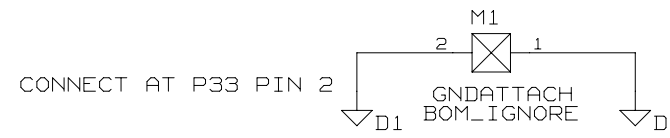
12 AWG WIRE TO CHASSIS

+6V

12 AWG WIRE

12 AWG WIRE

TO POWER SUPPLY



707A\_126.LOGIC.1.2

KEITHLEY KEITHLEY INSTRUMENTS INC. CLEVELAND, OHIO 44139			
DRAWING		SCHEMATIC, 707A BACKPLANE BOARD	
MODEL 707A	B	707A-126	
DRAWN MRS	APP JN	ECA 22749	REV B1
LAST_MODIFIED=Mon Nov 15 08:24:53 1999			

\*\*\* Signal Cross-Reference \*\*\*  
--- for the entire design ---

```

/CARD1      2C2
/CARD2      2C2
/CARD3      2C2
/CARD4      2C2
/CARD5      2B2
/CARD6      2B2
/NEXTADDR   2B2
CLK         2A2
CLRADDR     2B2
IDDATA      2B2
RELAYDATA   2A2
ROW A GD (<7071>) 1D2 1D2 1D3 1D4 1D5 1D6 1D7 1D8
ROW A HI (<7071>) 1D2 1D2 1D3 1D4 1D5 1D6 1D7 1D8
ROW A LO (<7071>) 1D2 1D2 1D3 1D4 1D5 1D6 1D7 1D8
ROW B GD (<7071>) 1C2 1C2 1C3 1C4 1C5 1C6 1C7 1C8
ROW B HI (<7071>) 1D2 1D2 1D3 1D4 1D5 1D6 1D7 1D8
ROW B LO (<7071>) 1C2 1C2 1C3 1C4 1C5 1C6 1C7 1C8
ROW C GD (<7071>) 1C2 1C2 1C3 1C4 1C5 1C6 1C7 1C8
ROW C HI (<7071>) 1C2 1C2 1C3 1C4 1C5 1C6 1C7 1C8
ROW C HI (<7072>) 1D2 1D2 1D3 1D4 1D5 1D6 1D7 1D8
ROW C LO (<7071>) 1C2 1C2 1C3 1C4 1C5 1C6 1C7 1C8
ROW C LO (<7072>) 1D2 1D2 1D3 1D4 1D5 1D6 1D7 1D8
ROW D GD (<7071>) 1C2 1C2 1C3 1C4 1C5 1C6 1C7 1C8
ROW D HI (<7071>) 1C2 1C2 1C3 1C4 1C5 1C6 1C7 1C8
ROW D HI (<7072>) 1D2 1D2 1D3 1D4 1D5 1D6 1D7 1D8
ROW D LO (<7071>) 1C2 1C2 1C3 1C4 1C5 1C6 1C7 1C8
ROW D LO (<7072>) 1D2 1D2 1D3 1D4 1D5 1D6 1D7 1D8
ROW E GD (<7071>) 1C2 1C2 1C3 1C4 1C5 1C6 1C7 1C8
ROW E HI (<7071>) 1C2 1C2 1C3 1C4 1C5 1C6 1C7 1C8
ROW E HI (<7072>) 1D2 1D2 1D3 1D4 1D5 1D6 1D7 1D8
ROW E LO (<7071>) 1C2 1C2 1C3 1C4 1C5 1C6 1C7 1C8
ROW E LO (<7072>) 1D2 1D2 1D3 1D4 1D5 1D6 1D7 1D8
ROW F GD (<7071>) 1C2 1C2 1C3 1C4 1C5 1C6 1C7 1C8
ROW F HI (<7071>) 1C2 1C2 1C3 1C4 1C5 1C6 1C7 1C8
ROW F HI (<7072>) 1D2 1D2 1D3 1D4 1D5 1D6 1D7 1D8
ROW F LO (<7071>) 1C2 1C2 1C3 1C4 1C5 1C6 1C7 1C8
ROW F LO (<7072>) 1D2 1D2 1D3 1D4 1D5 1D6 1D7 1D8
ROW G GD (<7071>) 1C2 1C2 1C3 1C4 1C5 1C6 1C7 1C8
ROW G HI (<7071>) 1C2 1C2 1C3 1C4 1C5 1C6 1C7 1C8
ROW G LO (<7071>) 1C2 1C2 1C3 1C4 1C5 1C6 1C7 1C8
ROW H GD (<7071>) 1B2 1B2 1B3 1B4 1B5 1B6 1B7 1B8
ROW H HI (<7071>) 1B2 1B2 1B3 1B4 1B5 1B6 1B7 1B8
ROW H LO (<7071>) 1B2 1B2 1B3 1B4 1B5 1B6 1B7 1B8
STROBE      2B2

```

CREFOUT.LOGIC.1.3

KEITHLEY		KEITHLEY INSTRUMENTS INC. CLEVELAND, OHIO 44139	
DRAWING	CROSS REFERENCER	707A	
		(SIGNALS)	
MODEL 707A	B	707A-126	
DRAWN MRS	APP JN	ECA 22749	REV B1
LAST_MODIFIED=Mon Nov 15 08:28:16 1999			

8

7

6

5

4

3

2

1

\*\*\* Unit Cross-Reference \*\*\*  
--- for the entire design ---

J19 CA-27-7 2C1  
 J101 CS-579-1 1D7  
 J102 CS-579-1 1D6  
 J103 CS-579-1 1D6  
 J104 CS-579-1 1D4  
 J105 CS-579-1 1D3  
 J106 CS-579-1 1D2  
 J107 CS-591-2 1B7  
 J108 CS-591-2 1B6  
 J109 CS-591-2 1B6  
 J110 CS-591-2 1B4  
 J111 CS-591-2 1B3  
 J112 CS-591-2 1B2  
 J113 CS-591-1 2D8  
 J114 CS-591-1 2D7  
 J115 CS-591-1 2D6  
 J116 CS-591-1 2D4  
 J117 CS-591-1 2D3  
 J118 CS-591-1 2D2  
 M1 GNDATTACH 2A3  
 W1 J-7-3 1D5  
 W2 J-7-3 1D5  
 W3 J-7-3 1D5  
 W4 J-7-3 1D5  
 W5 J-7-3 1D5  
 W6 J-7-3 1D5  
 W7 J-7-3 1D5  
 W8 J-7-3 1D5  
 W9 J-7-3 1D5  
 W10 J-7-3 1D5  
 W11 J-7-3 1D5  
 W12 J-7-3 1D5  
 W13 J-7-3 1C5  
 W14 J-7-3 1C5  
 W15 J-7-3 1C5  
 W16 J-7-3 1C5  
 W17 J-7-3 1C5  
 W18 J-7-3 1C5  
 W19 J-7-3 1C5  
 W20 J-7-3 1C5  
 W21 J-7-3 1C5  
 W22 J-7-3 1C5  
 W23 J-7-3 1C5  
 W24 J-7-3 1C5  
 W25 J-7-3 1C5  
 W26 J-7-3 1C5  
 W27 J-7-3 1C5  
 W28 J-7-3 1C5  
 W29 J-7-3 1C5  
 W30 J-7-3 1B5  
 W31 J-7-3 1B5  
 W32 J-7-3 1B5  
 W33 J-7-3 1A2

CREFOUT.LOGIC.1.4

KEITHLEY		KEITHLEY INSTRUMENTS INC. CLEVELAND, OHIO 44139	
DRAWING	CROSS REFERENCER (COMPONENTS)	707A	
MODEL 707A	B	707A-126	
DRAWN MRS	APP JN	ECA 22749	REV B1
LAST_MODIFIED=Mon Nov 15 08:31:13 1999			

8

7

6

5

4

3

2

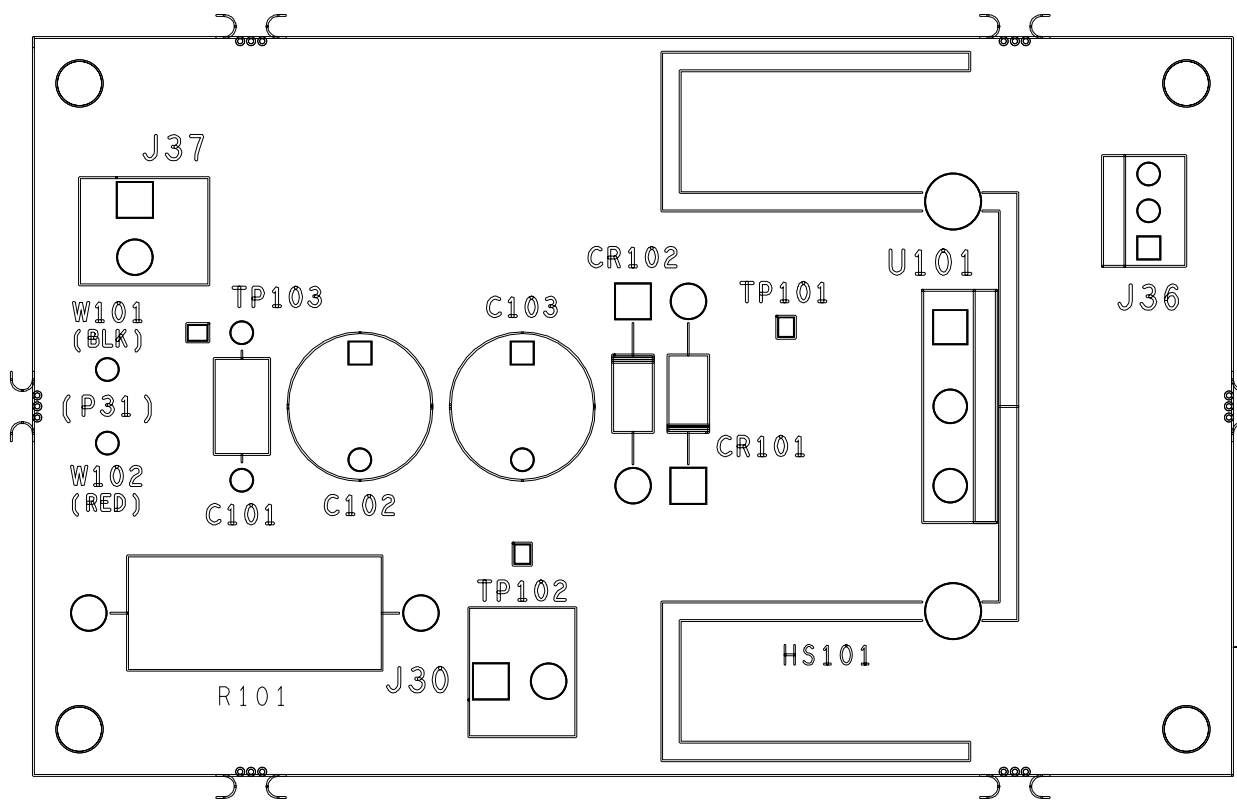
1

PG. 4 OF 4

707A-160

ON

LTR.	ECA NO.	REVISION	ENG.	DATE
B	21786	RELEASED	SZ	7/28/98
C	22121	ADDED EXTRA SUPPORT TABS	JBN	11/10/98



MOUNTING HARDWARE  
 #6-32x7/8" PPH  
 #6FBRWA  
 #6-32KEPNUT  
 HS-49-2  
 (NOT SHOWN)

707A-162

NOTE: FOR COMPONENT INFORMATION, REFER TO 707A PRODUCT STRUCTURE.

MODEL	NEXT ASSEMBLY	QTY.
USED ON		

**KEITHLEY**  
 KEITHLEY INSTRUMENTS INC.  
 CLEVELAND, OHIO 44139

DIM ARE IN IN. UNLESS OTHERWISE NOTED  
 DIM. TOL. UNLESS OTHERWISE SPECIFIED  
 XX=+.01      ANG.=+1  
 XXX=+.005    FRAC.=+1/64

DATE 7/15/98      SCALE 2:1  
 DRN ELS            APPR. PS  
 DO NOT SCALE THIS DRAWING

TITLE COMPONENT LAYOUT, VOLTAGE REGULATOR  
 NO. 707A-160



# A

## Card Configuration Worksheet

**Slot:** \_\_\_\_\_ **Model:** \_\_\_\_\_

Mainframe: Stand-alone \_\_\_\_\_

Master \_\_\_\_\_ Slave 1 \_\_\_\_\_ Slave 2 \_\_\_\_\_ Slave 3 \_\_\_\_\_ Slave 4 \_\_\_\_\_

**System size:** \_\_\_\_\_ rows \_\_\_\_\_ columns \_\_\_\_\_ IEEE address \_\_\_\_\_

FROM (Instrument connection or DUT pin)	External Card Connection	TO (Instrument connection or DUT pin)
	<b>Row</b> A	
	B	
	C	
	D	
	E	
	F	
	G	
	H	
	<b>Column</b> 1	
	2	
	3	
	4	
	5	
	6	
	7	
	8	
	9	
	10	
	11	
	12	

**Expansion:**

<input type="checkbox"/> Backplane bus (rows through ribbon cable)	<input type="checkbox"/> SMB coax jumpers (rows)
<input type="checkbox"/> Point to point wiring (rows/cols.)	<input type="checkbox"/> Mass terminated cable (rows/cols.)
<input type="checkbox"/> BNC coax cable (rows/cols.)	<input type="checkbox"/> Triax cable (rows/cols.)

**Notes:**

# B

## IEEE-488 Bus Overview

---

### B.1 Introduction

The IEEE-488 bus is a communication system between two or more electronic devices. A device can be either an instrument or a computer. When a computer is used on the bus, it serves as a supervisor of the communication exchange between all the devices and is known as the controller. Supervision by the controller consists of determining which device will talk and which device will listen. As a talker, a device will output information. As a listener, a device will receive information. To simplify the task of keeping track of the devices, a unique address number is assigned to each.

On the bus, only one device can talk at a time and is addressed to talk by the controller. The device that is talking is known as the active talker. The devices that need to listen to the talker are addressed to listen by the controller. Each listener is then referred to as an active listener. Devices that do not need to listen are instructed to unlisten. The reason for the unlisten instruction is to optimize the speed of bus information transfer since the task of listening takes up bus time.

Through the use of control lines, a handshake sequence takes place in the transfer process of information from a talker to a listener. This handshake sequence helps ensure the credibility of the information transfer. The basic handshake sequence between an active controller (talker) and a listener is:

1. The listener indicates that it is ready to listen.
2. The talker places the byte of data on the bus and indicates that the data is available to the listener.
3. The listener, aware that the data is available, accepts the data and then indicates that the data has been accepted.
4. The talker, aware that the data has been accepted, stops sending data and indicates that data is not being sent.

5. The listener, aware that there is no data on the bus, indicates that it is ready for the next byte of data.

### B.2 Bus description

The IEEE-488 bus, which is also referred to as the GPIB (General Purpose Interface Bus), was designed as a parallel transfer medium to optimize data transfer without using an excessive number of bus lines. In keeping with this goal, the bus has only eight data lines that are used for data and with most commands. Five bus management lines and three handshake lines round out the complement of bus signal lines.

A typical setup for controlled operation is shown in Figure B-1. Generally, a system will contain one controller and a number of other instruments to which the commands are given. Device operation is categorized into three operators: controller, talker, and listener. The controller controls the instruments on the bus. The talker sends data while a listener receives data. Depending on the type of instrument, any particular device can be a talker only, a listener only, or both a talker and listener.

There are two categories of controllers: system controller and basic controller. Both are able to control other instruments, but only the system controller has the absolute authority in the system. In a system with more than one controller, only one controller may be active at any given time. Certain protocol is used to pass control from one controller to another.

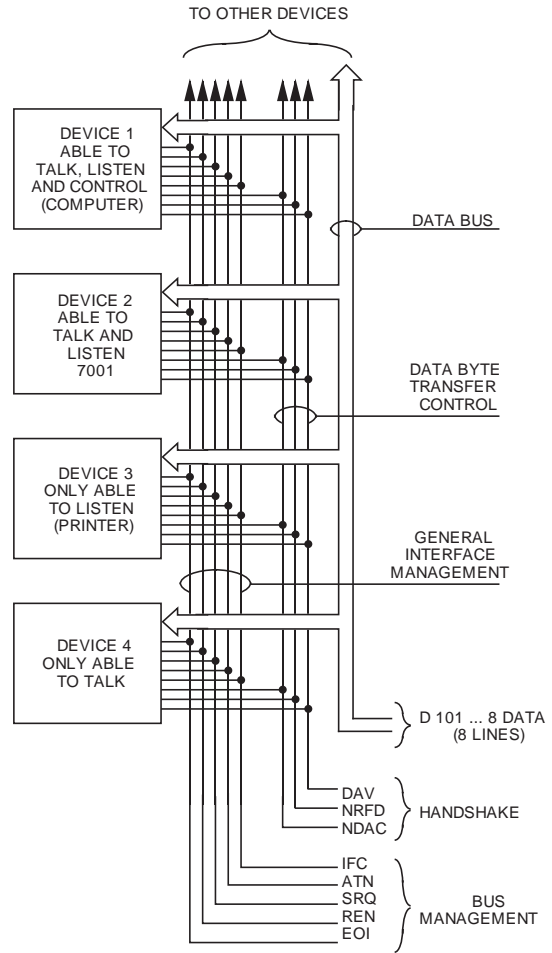
The IEEE-488 bus is limited to 15 devices, including the controller. Thus, any number of talkers and listeners up to that limit may be present on the bus at one time. Although several devices may be commanded to listen simultaneously,

the bus can have only one active talker, or communications would be scrambled.

A device is placed in the talk or listen state by sending an appropriate talk or listen command. These talk and listen commands are derived from an instrument's primary address. The primary address may have any value between 0 and 31, and is generally set by rear panel DIP switches or programmed in from the front panel of the instrument. The actual listen address value sent out over the bus is obtained by ORing the primary address with \$20. For example, if the primary address is \$16, the actual listen address is \$36 ( $\$36 = \$16 + \$20$ ). In a similar manner, the talk address is obtained by ORing the primary address with \$40. With the present example, the talk address derived from a primary address of \$16 would be \$56 ( $\$56 = \$16 + \$40$ ).

The IEEE-488 standards also include another addressing mode called secondary addressing. Secondary addresses lie in the range of \$60-\$7F. Note, however, that many devices, including the Model 707A, do not use secondary addressing.

Once a device is addressed to talk or listen, the appropriate bus transactions take place. For example, if the instrument is addressed to talk, it places its data string on the bus one byte at a time. The controller reads the information, and the appropriate software can be used to direct the information to the desired location.



**Figure B-1**  
IEEE-488 bus configuration

## B.3 Bus lines

The signal lines on the IEEE-488 bus are grouped into three different categories: data lines, management lines, and handshake lines. The data lines handle bus data and commands, while the management and handshake lines ensure that proper data transfer and operation take place. Each bus line is active low, with approximately zero volts representing a logic 1 (true). The following paragraphs describe the operation of these lines.

### B.3.1 Data lines

The IEEE-488 bus uses eight data lines that transfer data one byte at a time. DIO1 (Data Input/Output) through DIO8 (Data Input/Output) are the eight bi-directional data lines used to transmit both data and multiline commands. The data lines operate with low true logic.

### B.3.2 Bus management lines

The five bus management lines help to ensure proper interface control and management. These lines are used to send the uniline commands.

- ATN (Attention) — The state of the ATN line determines how information on the data bus is to be interpreted.
- IFC (Interface Clear) — The IFC line controls clearing of instruments from the bus.
- REN (Remote Enable) — The REN line is used to place the instrument on the bus in the remote mode.
- EOI (End or Identify) — The EOI line is used to mark the end of a multi-byte data transfer sequence.
- SRQ (Service Request) — The SRQ line is used by devices when they require service from the controller.

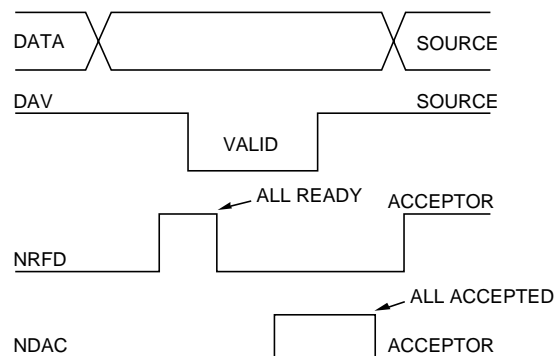
### B.3.3 Handshake lines

The bus handshake lines operate in an interlocked sequence. This method ensures reliable data transmission regardless of the transfer rate. Generally, data transfer will occur at a rate determined by the slowest active device on the bus.

One of the three handshake lines is controlled by the source (the talker sending information), while the remaining two lines are controlled by accepting devices (the listener(s) receiving the information). The three handshake lines are:

- DAV (DATA VALID) — The source controls the state of the DAV line to indicate to any listening devices whether or not data bus information is valid.
- NRFD (Not Ready For Data) — The acceptor controls the state of NRFD. It is used to signal to the transmitting device to hold off the byte transfer sequence until the accepting device is ready.
- NDAC (Not Data Accepted) — NDAC is also controlled by the accepting device. The state of NDAC tells the source whether or not the device has accepted the data byte.

The complete handshake sequence for one data byte is shown in Figure B-2. Once data is placed on the data lines, the source checks to see that NRFD is high, indicating that all active devices are ready. At the same time, NDAC should be low from the previous byte transfer. If these conditions are not met, the source must wait until NDAC and NRFD have the correct status. If the source is a controller, NRFD and NDAC must be stable for at least 100ns after ATN is set true. Because of the possibility of a bus hang up, many controllers have time-out routines that display messages in case the transfer sequence stops for any reason.



**Figure B-2**  
IEEE-488 handshake sequence

Once all NDAC and NRFD are properly set, the source sets DAV low, indicating to accepting devices that the byte on the data lines is now valid. NRFD will then go low, and NDAC will go high once all devices have accepted the data. Each device will release NDAC at its own rate, but NDAC will not be released to go high until all devices have accepted the data byte.

The previous sequence is used to transfer both data, talk, and listen addresses, as well as multiline commands. The state of the ATN line determines whether the data bus contains data, addresses, or commands as described in the following paragraphs.

## B.4 Bus commands

The instrument may be given a number of special bus commands through the IEEE-488 interface. The following paragraphs briefly describe the purpose of the bus commands that are grouped into the following categories.

- **Uniline commands** — Sent by setting the associated bus lines true. For example, to assert REN (Remote Enable), the REN line would be set low (true).
- **Multiline commands** — General bus commands that are sent over the data lines with the ATN line true (low).
- **Common commands** — Commands that are common to all devices on the bus and are sent with ATN high (false).
- **SCPI commands** — Commands that are particular to each device on the bus and are sent with ATN (false).

These bus commands and their general purpose are summarized in Table B-1.

### B.4.1 Uniline commands

ATN, IFC, and REN are asserted only by the controller. SRQ is asserted by an external device. EOI may be asserted either

by the controller or other devices depending on the direction of data transfer. The following is a description of each command. Each command is sent by setting the corresponding bus line true.

- **REN (Remote Enable)** — REN is sent to set up instruments on the bus for remote operation. When REN is true, devices will be removed from the local mode. Depending on device configuration, all front panel controls except the LOCAL button (if the device is so equipped) may be locked out when REN is true. Generally, REN should be sent before attempting to program instruments over the bus.
- **EOI (End or Identify)** — EOI is used to positively identify the last byte in a multi-byte transfer sequence, thus allowing data words of various lengths to be transmitted easily.
- **IFC (Interface Clear)** — IFC is used to clear the interface and return all devices to the talker and listener idle states.
- **ATN (Attention)** — The controller sends ATN while transmitting addresses or multiline commands.
- **SRQ (Service Request)** — SRQ is asserted by a device when it requires service from a controller.

**Table B-1**  
*IEEE-488 bus command summary*

Command type	Command	State of ATN line	Comments
Uniline	REN (Remote Enable)	X	Set up devices for remote operation.
	EOI	X	Marks end of transmission.
	IFC (Interface Clear)	X	Clears interface.
	ATN (Attention)	Low	Defines data bus contents.
	SRQ	X	Controlled by external device.
Multiline Universal	LLO (Local Lockout)	Low	Locks out local operation.
	DCL (Device Clear)	Low	Returns device to default conditions.
	SPE (Serial Enable)	Low	Enables serial polling.
	SPD (Serial Poll Disable)	Low	Disables serial polling.
Addressed	SDC (Selective Device Clear)	Low	Returns unit to default conditions.
	GTL (Go To Local)	Low	Returns device to local.
Unaddressed	UNL (Unlisten)	Low	Removes all listeners from the bus.
	UNT (Untalk)	Low	Removes any talkers from the bus.

## B.4.2 Universal multiline commands

Universal commands are those multiline commands that require no addressing. All devices equipped to implement such commands will do so simultaneously when the commands are transmitted. As with all multiline commands, these commands are transmitted with ATN true.

- LLO (Local Lockout) — LLO is sent to the instrument to lock out the LOCAL key and all their front panel controls.
- DCL (Device Clear) — DCL is used to return instruments to some default state. Instruments usually return to their power-up conditions.
- SPE (Serial Poll Enable) — SPE is the first step in the serial polling sequence that is used to determine which device has requested service.
- SPD (Serial Poll Disable) — SPD is used by the controller to remove all devices on the bus from the serial poll mode and is generally the last command in the serial polling sequence.

## B.4.3 Addressed multiline commands

Addressed commands are multiline commands that must be preceded by the device listen address before that instrument will respond to the command in question. Note that only the addressed device will respond to these commands. Both the commands and the address preceding it are sent with ATN true.

- SDC (Selective Device Clear) — The SDC command performs essentially the same function as the DCL command except that only the addressed device responds. Generally, instruments return to their power-up default conditions when responding to the SDC command.
- GTL (Go To Local) — The GTL command is used to remove instruments from the remote mode. With some instruments, GTL also unlocks front panel controls if they were previously locked out with the LLO command.
- GET (Group Execute Trigger) — The GET command is used to trigger devices to perform a specific action that depends on device configuration (for example, take a reading). Although GET is an addressed command, many devices respond to GET without addressing.

## B.4.4 Address commands

Addressed commands include two primary command groups and a secondary address group. ATN is true when these commands are asserted. The commands include:

- LAG (Listen Address Group) — These listen commands are derived from an instrument's primary address and are used to address devices to listen. The actual command byte is obtained by ORing the primary address with \$20.
- TAG (Talk Address Group) — The talk commands are derived from the primary address by ORing the address with \$40. Talk commands are used to address devices to talk.
- SCG (Secondary Command Group) — Commands in this group provide additional addressing capabilities. Many devices (including the Model 707A) do not use these commands.

## B.4.5 Unaddress commands

The two unaddress commands are used by the controller to remove any talkers or listeners from the bus. ATN is true when these commands are asserted.

- UNL (Unlisten) — Listeners are placed in the listener idle state by the UNL command.
- UNT (Untalk) — Any previously commanded talkers will be placed in the talker idle state by the UNT command.

## B.4.6 Command codes

Command codes for the various commands that use the data lines are summarized in Figure B-3. Hexadecimal and decimal values for the various commands are listed in Table B-2.

**Table B-2**  
*Hexadecimal and decimal command codes*

Command	Hex value	Decimal value
GTL	01	1
SDC	04	4
GET	08	8
LLO	11	17
DCL	14	20
SPE	18	24
SPD	19	25
LAG	20-3F	32-63
TAG	40-5F	64-95
SCG	60-7F	96-127
UNL	3F	63
UNT	5F	95

D <sub>7</sub> D <sub>6</sub> D <sub>5</sub> D <sub>4</sub>	D <sub>3</sub> ↓	D <sub>2</sub> ↓	D <sub>1</sub> ↓	D <sub>0</sub> ↓	Column → Row ↓	X	Command	X	Command	X	Primary Address	X	Primary Address	X	Primary Address	X	Primary Address	X	Primary Address
						0 (A)	0 (B)	1 (A)	1 (B)	2 (A)	2 (B)	3 (A)	3 (B)	4 (A)	4 (B)	5 (A)	5 (B)	6 (A)	6 (B)
0	0	0	0	0	0	0	NUL	0	DLE	0	0	@	0	P	0	16			
0	0	0	0	1	1	1	SOH	1	DC1	1	17	A	1	Q	1	17	a		
0	0	0	1	0	2	2	STX	2	DC2	2	18	B	2	R	2	18	b		
0	0	0	1	1	3	3	ETX	3	DC3	3	19	C	3	S	3	19	c		
0	1	0	0	0	4	4	EOT	4	DC4	4	20	D	4	T	4	20	d		
0	1	0	1	0	5	5	ENQ	5	PPC*	5	21	E	5	U	5	21	e		
0	1	1	0	0	6	6	ACK	6	SYN	6	22	F	6	V	6	22	f		
0	1	1	1	1	7	7	BEL	7	ETB	7	23	G	7	W	7	23	g		
1	0	0	0	0	8	8	BS	8	CAN	8	24	H	8	X	8	24	h		
1	0	0	1	0	9	9	HT	9	EM	9	25	I	9	Y	9	25	i		
1	0	1	0	0	10	10	LF	10	SUB	10	26	J	10	Z	10	26	j		
1	0	1	1	1	11	11	VT	11	ESC	11	27	K	11	[	11	27	k		
1	1	0	0	0	12	12	FF	12	FS	12	28	L	12	\	12	28	l		
1	1	1	0	1	13	13	CR	13	GS	13	29	M	13	]	13	29	m		
1	1	1	1	0	14	14	SO	14	RS	14	30	N	14	^	14	30	n		
1	1	1	1	1	15	15	SI	15	US	15	UNL	O	15	_	15	UNT	o		
						ADDRESS COMMAND GROUP (ACG)			LISTEN ADDRESS GROUP (LAG)			TALK ADDRESS GROUP (TAG)			SECONDARY COMMAND GROUP (SDC)				
						UNIVERSAL COMMAND GROUP (UCG)			PRIMARY COMMAND GROUP (PCG)										

\*PPC (PARALLEL POLL CONFIGURE) PPU (PARALLEL POLL UNCONFIGURE), and TCT (TAKE CONTROL) not implemented by Model 708.  
 Note: D<sub>0</sub> = DIO1 ... D<sub>7</sub> = DIO8; X = Don't Care.

Figure B-3  
 Command codes



## B.4.7 Typical command sequences

For the various multiline commands, a specific bus sequence must take place to properly send the command. In particular, the correct listen address must be sent to the instrument before it will respond to addressed commands. Table B-3 lists a typical bus sequence for sending the addressed multiline commands. In this instance, the SDC command is being sent to the instrument. UNL is generally sent as part of the sequence to ensure that no other active listeners are present. Note that ATN is true for both the listen command and the SDC command byte itself.

**Table B-3**  
Typical addressed command sequence

Step	Command	ATN state	Data bus		
			ASCII	Hex	Decimal
1	UNL	Set low	?	3F	63
2	LAG*	Stays low	0	30	48
3	SDC	Stays low	EOT	04	4
4		Returns high			

\*Assumes primary address = 16.

Table B-4 gives a typical common command sequence. In this instance, ATN is true while the instrument is being addressed, but it is set high while sending the common command string.

**Table B-4**  
Typical common command sequence

Step	Command	ATN state	Data bus		
			ASCII	Hex	Decimal
1	UNL	Set low	?	3F	63
2	LAG*	Stays low	0	30	48
3	Data	Set high	*	2A	42
4	Data	Stays high	R	52	82
5	Data	Stays high	S	53	83
6	Data	Stays high	T	54	84

\*Assumes primary address = 16.

## B.4.8 IEEE command groups

Command groups supported by the Model 707A are listed in Table B-5.

**Table B-5**  
IEEE command groups

<b>HANDSHAKE COMMAND GROUP</b>	
	NDAC = NOT DATA ACCEPTED NRFD = NOT READY FOR DATA DAV = DATA VALID
<b>UNIVERSAL COMMAND GROUP</b>	
	ATN = ATTENTION DCL = DEVICE CLEAR IFC = INTERFACE CLEAR REN = REMOTE ENABLE SPD = SERIAL POLL DISABLE SPE = SERIAL POLL ENABLE
<b>ADDRESS COMMAND GROUP</b>	
LISTEN	LAG = LISTEN ADDRESS GROUP MLA = MY LISTEN ADDRESS UNL = UNLISTEN
TALK	TAG = TALK ADDRESS GROUP MTA = MY TALK ADDRESS UNT = UNTALK OTA = OTHER TALK ADDRESS
<b>ADDRESSED COMMAND GROUP</b>	
	ACG = ADDRESSED COMMAND GROUP GTL = GO TO LOCAL SDC = SELECTIVE DEVICE CLEAR
<b>STATUS COMMAND GROUP</b>	
	RQS = REQUEST SERVICE SRQ = SERIAL POLL REQUEST STB = STATUS BYTE EOI = END

## B.5 Interface function codes

The interface function codes, which are part of the IEEE-488 standards, define an instrument's ability to support various interface functions and should not be confused with programming commands found elsewhere in this manual. The interface function codes for the Model 707A are listed in Table B-6.

**Table B-6**  
*Model 707A interface function codes*

Code	Interface function
SH1	Source Handshake capability
AH1	Acceptor Handshake capability
T5	Talker (basic talker, talk-only, serial poll, unaddressed to talk on LAG)
L4	Listener (basic listener, unaddressed to listen on TAG)
SR1	Service Request capability
RL1	Remote/Local capability
PP0	No Parallel Poll capability
DC1	Device Clear capability
DT1	Device Trigger capability
C0	No Controller capability
E1	Open collector bus drivers
TE0	No Extended Talker capability
LE0	No Extended Listener capability

The codes define Model 707A capabilities as follows:

- SH (Source Handshake Function) — SH1 defines the ability of the instrument to initiate the transfer of message/data over the data bus.

- AH (Acceptor Handshake Function) — AH1 defines the ability of the instrument to guarantee proper reception of message/data transmitted over the data bus.
- T (Talker Function) — The ability of the instrument to send data over the bus to other devices is provided by the T function. Instrument talker capabilities (T5) exist only after the instrument has been addressed to talk.
- L (Listener Function) — The ability of the instrument to receive device-dependent data over the bus from other devices is provided by the L function. Listener capabilities (L4) of the instrument exist only after it has been addressed to listen.
- SR (Service Request Function) — SR1 defines the ability of the instrument to request service from the controller.
- RL (Remote/Local Function) — RL1 defines the ability of the instrument to be placed in the remote or local modes.
- PP (Parallel Poll Function) — The instrument does not have parallel polling capabilities (PP0).
- DC (Device Clear Function) — DC1 defines the ability of the instrument to be cleared (initialized).
- DT (Device Trigger Function) — DT1 defines the ability of the Model 708 to have readings triggered.
- C (Controller Function) — The instrument does not have controller capabilities (C0).
- E (Bus Driver Type) — The instrument has open-collector bus drivers (E1).
- TE (Extended Talker Function) — The instrument does not have extended talker capabilities (TE0).
- LE (Extended Listener Function) — The instrument does not have extended listener capabilities (LE0).

# Index

---

## A

A — External trigger 5-16  
Address commands B-5  
Address decoding 6-2  
Addressed multiline commands B-5  
Alphanumeric display 4-4

## B

B — Matrix ready 5-17  
Backplane 7-16  
Backplane jumpers 7-7  
Basic switching operation 3-22  
Battery replacement 7-9  
Bus cable connections 5-3  
Bus commands B-4  
Bus description B-1  
Bus lines B-3  
Bus management lines B-3

## C

C — Close crosspoint 5-18  
Card configuration worksheet A-1  
Card connections 3-8  
Card installation 2-1  
Card labels 4-18  
Cleaning 7-16  
Command codes B-5  
Component layouts and schematics 8-1  
Concurrent front panel and bus operation 5-10  
Control signals 6-17  
Copying crosspoint display 4-11  
Crosspoint display LEDs 4-6

## D

D — Display 5-18  
Data lines B-3  
DCL (device clear) 5-11  
Device-dependent command (DDC) programming 5-12

Digital board checks 7-10  
Digital I/O 4-14, 6-17  
Disassembly 7-5  
Display board checks 7-14  
Display circuitry 6-10  
Display data 6-13  
Display interface 6-13  
Display messages 4-5  
Displays and messages 4-4  
Documenting system configuration 3-20

## E

E — Edit pointer 5-19  
Expanding matrix size 3-10  
External trigger 4-14  
External trigger input 4-25

## F

F — Enable/disable triggers 5-19  
Factory defaults 4-18  
Factory service 8-1  
Fan filter 7-16  
Features 1-1  
Fixed rack installation 7-2  
Front panel aspects of IEEE-488 operation 5-8  
Front panel error messages 5-8  
Front panel familiarization 3-1  
Front panel keys 6-13  
Front panel triggering 4-21  
Fuse replacement 7-2

## G

G — Data format 5-20  
General bus command programming 5-10  
General information 1-1  
GET (group executive trigger) 5-11  
Getting started 3-1  
GTL (go to local) 5-11

## H

H — Hit key 5-25  
Handshake lines B-3

## I

I — Insert blank setup 5-26  
IEEE command groups B-7  
IEEE-488 bus address 4-17  
IEEE-488 bus interface 6-17  
IEEE-488 bus overview B-1  
IEEE-488 bus triggering 4-25  
IEEE-488 programming 5-1  
IEEE-488 quick start 5-1  
IEEE-488 status indicators 4-6  
IFC (interface clear) 5-11  
Inserting and deleting stored setups 4-12  
Inspection for damage 1-2  
Installing and removing cards 2-1  
Interface function codes 5-5, B-8  
Introduction 1-1, 3-1, 4-1, 5-1, 6-1, 7-1, 8-1, B-1

## J

J — Self-test 5-26

## K

K — EOI and hold-off 5-26

## L

L — Download setups 5-27  
Light pen 4-8  
Light pen interface 6-14  
Line power connections 4-2  
Line voltage selection 4-2  
Line voltage sensing 7-1  
LLO (local lockout) 5-11  
Local key 5-10

## M

M — SRQ and serial poll byte 5-28  
Mainframe troubleshooting 7-9  
Maintenance 7-1  
Make/break and break/make LEDs 4-8  
Make/break and break/make rows 4-19  
Manual addenda 1-1  
Master/slave circuitry 6-15  
Master/slave power-up 4-4  
Matrix ready 4-15  
Matrix ready output 4-25  
Memory 6-4  
Menu operations 4-12  
Microcomputer 6-1  
Modifying a relay setup 3-22  
Modifying crosspoint display 4-10  
Multiple unit expansion 3-16

## N

N — Open crosspoint 5-30

## O

O — Digital output 5-30  
Operation 4-1  
Optional accessories 1-2  
Ordering information 8-1  
Overall function description 6-1  
Overview 5-10, 5-12

## P

P — Clear crosspoints 5-31  
Parts lists 8-1  
Power supply 6-19  
Power supply checks 7-10  
Power switch 4-2  
Power-up 3-22  
Power-up configuration 4-3  
Power-up procedure 4-2  
Power-up self-test 7-10  
Power-up self-test and messages 4-2  
Primary address programming 5-6  
Principles of operation 6-1  
Programmed settling time 4-19

## Q

Q — Delete setup 5-31  
QuickBASIC programming 5-7

## R

R — Restore defaults 5-32  
Rear panel familiarization 3-6  
Recommended test equipment 7-10  
Refresh display/read keyboard 6-14  
Relay command combinations 5-42  
Relay control circuitry 6-4  
Relay (hardware) settling times 4-18  
REN (remote enable) 5-10  
Repacking for shipment 1-2  
Replaceable parts 8-1  
Reset circuit 6-1  
Resetting 4-25

## S

S — Programmed settling time 5-32  
Safety symbols and terms 1-2  
SDC (selective device clear) 5-11  
Selecting crosspoint display 4-10  
Selecting make/break and break/make rows 3-22  
Selecting switching parameters 4-19  
Self-test 4-18  
Serial communication 6-15  
Setup data paths 4-1  
Shipment contents 1-2  
Single unit expansion 3-10  
SPE, SPD (serial polling) 5-11  
Specifications 1-2  
Stand-alone and master/slave 4-16  
Static-sensitive devices 7-9  
Status indicators 5-9  
Storing setup and sending to relays 3-23  
Switching card interface 6-6  
Switching card logic 6-6  
System expansion issues 3-20

## T

T — Trigger 5-33  
Timing considerations 5-43  
Trigger overrun conditions 4-21  
Trigger sources 4-20  
Triggering 4-20  
Typical command sequences B-7

## U

U — Status 5-34  
Unaddress commands B-5  
Uniline commands B-4  
Universal multiline commands B-5  
Unpacking and inspection 1-2  
Using an extender card 7-16

## V

V — Make/break 5-39

## W

W — Break/make 5-39  
Warranty information 1-1

## X

X — Execute 5-40

## Y

Y — Terminator 5-41

## Z

Z — Copy setup 5-41



# Service Form

Model No. \_\_\_\_\_ Serial No. \_\_\_\_\_ Date \_\_\_\_\_

Name and Telephone No. \_\_\_\_\_

Company \_\_\_\_\_

List all control settings, describe problem and check boxes that apply to problem. \_\_\_\_\_

- |  |  |  |
|--|--|--|
| <input type="checkbox"/> Intermittent            | <input type="checkbox"/> Analog output follows display   | <input type="checkbox"/> Particular range or function bad; specify _____ |
| <input type="checkbox"/> IEEE failure            | <input type="checkbox"/> Obvious problem on power-up     | <input type="checkbox"/> Batteries and fuses are OK                      |
| <input type="checkbox"/> Front panel operational | <input type="checkbox"/> All ranges or functions are bad | <input type="checkbox"/> Checked all cables                              |

Display or output (check one)

- |                                   |  |
|-----------------------------------|--|
| <input type="checkbox"/> Drifts   | <input type="checkbox"/> Unable to zero              |
| <input type="checkbox"/> Unstable | <input type="checkbox"/> Will not read applied input |
| <input type="checkbox"/> Overload |  |

- |   |  |
|---|--|
| <input type="checkbox"/> Calibration only | <input type="checkbox"/> Certificate of calibration required |
| <input type="checkbox"/> Data required    |  |

(attach any additional sheets as necessary)

Show a block diagram of your measurement system including all instruments connected (whether power is turned on or not). Also, describe signal source.

Where is the measurement being performed? (factory, controlled laboratory, out-of-doors, etc.)

What power line voltage is used? \_\_\_\_\_ Ambient temperature? \_\_\_\_\_ °F

Relative humidity? \_\_\_\_\_ Other? \_\_\_\_\_

Any additional information. (If special modifications have been made by the user, please describe.)

Be sure to include your name and phone number on this service form.



**Keithley Instruments, Inc.**

28775 Aurora Road  
Cleveland, Ohio 44139

Printed in the U.S.A.